

NEW TYPE

LOW FRICTION VACUUM PAD HOLDER CLF SERIES



※ Fitting and vacuum pad is excluded.

M14 Product is launched !
For 20Ø~50Ø PAD

M10 For 0.7Ø~15Ø PAD



1/10 Reduced particle
(than current product)

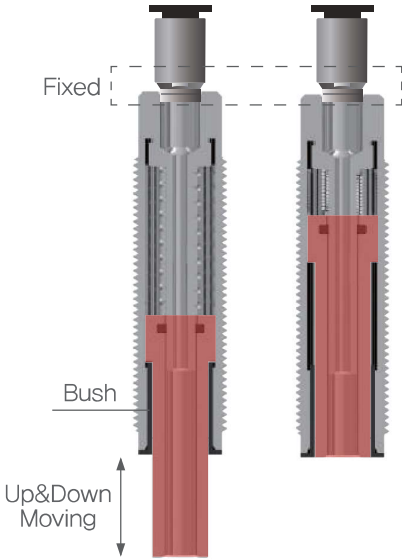

Holder inner structure

Copper Free



Low Friction, Low Noise!
Noise level **45dB**

Smooth up&down moving
according to non-eccentric structure.

Stuck shaft problem
according to tube's tension was solved!

Order Information

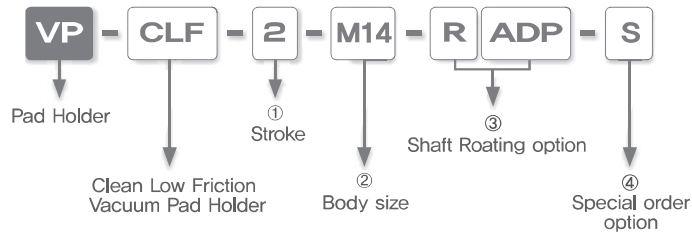

① Stroke

Code	2	5	10	15	20
Stroke	2mm	5mm	10mm	15mm	20mm

※ M10 body size product only has 2 stroke option

② Body size

Code	No Code	M14
Option	M10 x P1,0	M14 x P1,0

③ Shaft Roating option

Code	No Code	Roating Type
Option	Non-rotating	R-ADP

※ Non rotating type is standard on VP-CLF
 Please note R-ADP(Adaptor),
 in case of using rotating type.

④ Special order option

Code	No Code	S
Option	Standard	Special Ordered Products

Dimension (mm)

VP-CLF

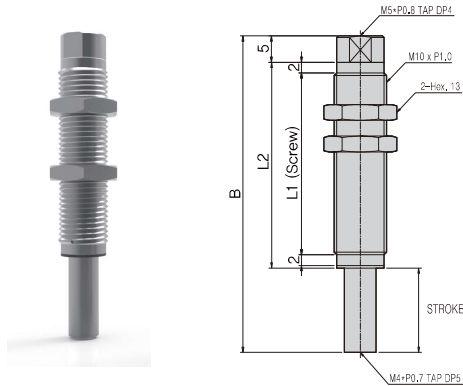

Spec	B	L1	L2	Stroke
VP-CLF-2	34	21,5	26	2
VP-CLF-5	40	24,5	29	5
VP-CLF-10	50	29,5	34	10
VP-CLF-15	60	34,5	39	15
VP-CLF-20	65	39,5	44	20

VP-CLF-□-M14

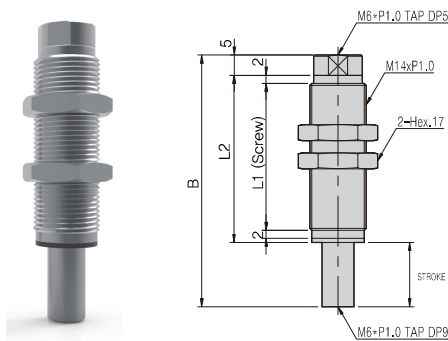

Spec	B	L1	L2	Stroke
VP-CLF-5-M14	42,5	26,5	31,5	5
VP-CLF-10-M14	52,5	31,5	36,5	10
VP-CLF-15-M14	62,5	36,5	41,5	15
VP-CLF-20-M14	72,5	41,5	46,5	20

Structure map

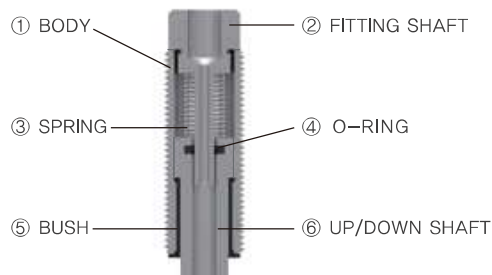

No.	DESC	MATERIAL
①	BODY	SUS
②	FITTING SHAFT	SUS
③	SPRING	SUS
④	O-RING	Oil Bleed Type
⑤	BUSH	Eng Plastic
⑥	UP/DOWN SHAFT	SUS