

- ✓ Embedded Controller
- ✓ Position Table
- ✓ Closed Loop System
- ✓ No Gain Tuning / No Hunting
- ✓ Heat Reduction / Torque Improvement



1. CC-Link Based Motion Control

Hi STEP CC-Link is a stepping motor control system that supports CC-Link with high speed fieldbus (max. 10Mbps).

Hi STEP CC-Link is a remote device module supporting CC-Link network. Multi-function control is possible by occupying 1 station and 2 stations in CC-Link, and motion and monitoring functions are processed by device commands.

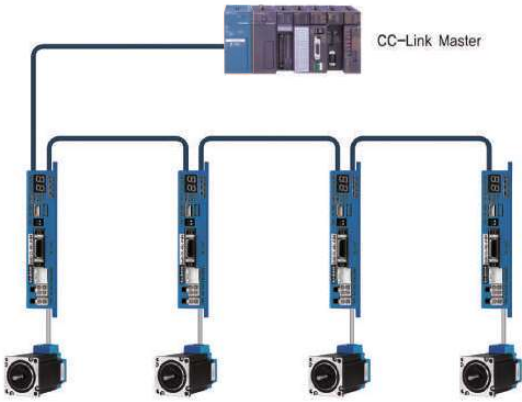

2. Closed Loop System

Hi STEP is an innovative closed loop stepping system that utilizes a high-resolution motor mounted encoder constantly to monitor the current position. The encoder feedback allows the Hi STEP to update the current position every 50 micro seconds. It allows the Hi STEP drive to compensate for the loss of position, ensuring accurate positioning. For example, due to a sudden load change, a conventional stepper motor and drive could lose a step but Hi STEP automatically correct the position by encoder feedback.

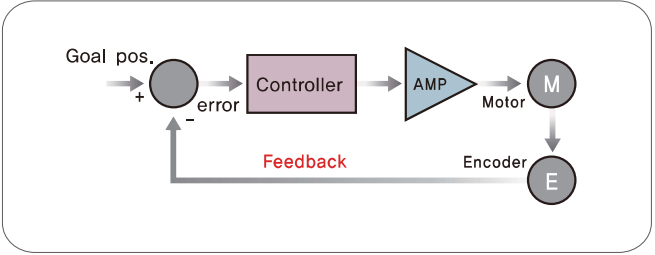

3. No Gain Tuning

To ensure machine performance, smoothness, positional error and low servo noise, conventional servo systems require the adjustment of its servo's gains as an initial crucial step. Even systems that employ auto-tuning require manual tuning after the system is installed, especially if more than one axis are interdependent. Hi STEP employs the best characteristics of stepper, closed loop motion controls and algorithms to eliminate the need of tedious gain tuning required for conventional closed loop servo systems. This means that Hi STEP is optimized for the application and ready to work right out of the box. The Hi STEP system employs the unique characteristics of the closed loop stepping motor control, eliminating these cumbersome steps and giving the engineer a high performance servo system without wasting setup time. Hi STEP is especially well suited for low stiffness loads (for example, a belt and pulley system) that sometime require conventional systems to inertia match

with the additional expensive and bulky gearbox. Hi STEP also perform exceptionally, even under heavy loads and high speeds.

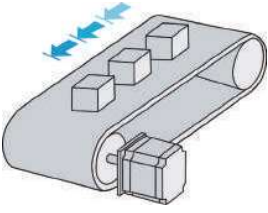

4. Heat Reduction / Energy Saving

(Motor Current Control according to load)

Hi STEP automatically controls motor current according to load.

Hi STEP reduces motor current when motor load is low, and increases motor current when load is high. By optimizing the motor current, motor heat can be minimized and energy can be saved.

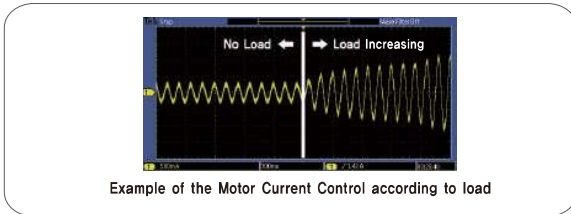
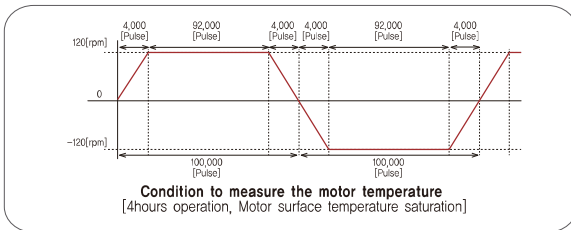
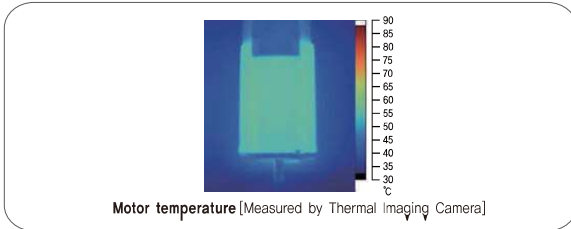

5. Torque Improvement

(Motor Voltage Increasing and Motor Current Setting)

Hi STEP boosts the voltage supplied to the motor by internal DC-DC Converter. The torque at the high speed is increased. In addition, it is possible to set the Run Current up to 150%, whereby the torque at low speed is increased.

Torque can be improved by about 30% over the entire speed range.

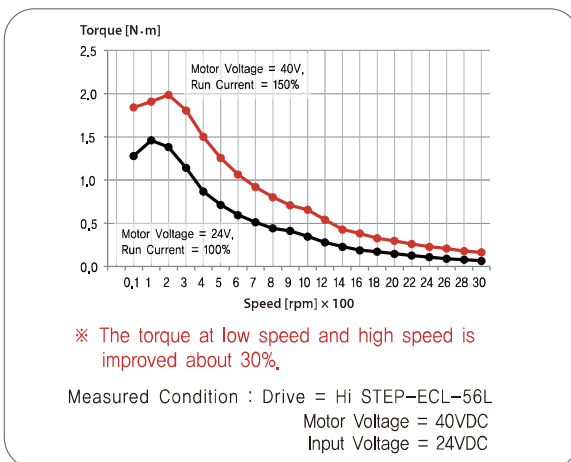

6. No Hunting

Traditional CC-Link motor drives overshoot their position and try to correct by overshooting the opposite direction, especially in high gain applications. This is called null hunt and is especially prevalent in systems that the break away or static friction is significantly higher than the running friction. The cure is lowering the gain, which affects accuracy or using Hi STEP Motion Control System. Hi STEP utilizes the unique characteristics of stepping motors and locks itself into the desired target position, eliminating Null Hunt. This feature is especially useful in applications such as nanotech manufacturing, semiconductor fabrication, vision systems and ink jet printing in which system oscillation and vibration could be a problem.

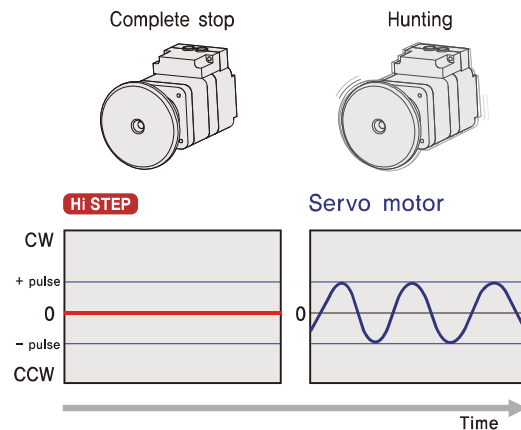

7. Smooth and Accurate

Hi STEP is a high-precision servo drive, using a high-resolution encoder with 20,000 pulses/revolution. Unlike a conventional Microstep drive, the on-board high performance ARM (Advanced RISC Machine) performs vector control and filtering, producing a smooth rotational control with minimum ripples.

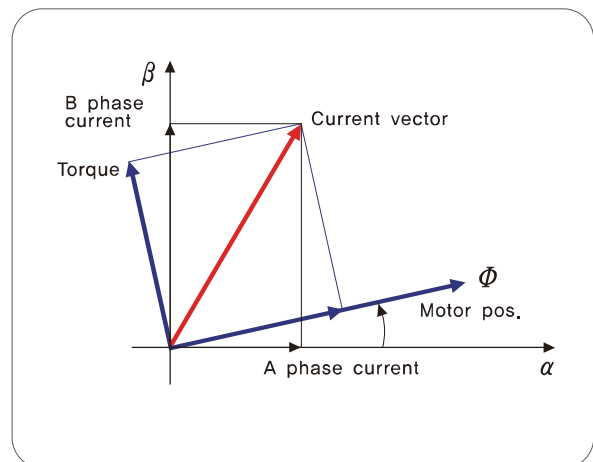

8. Fast Response

Similar to conventional stepping motors, Hi STEP instantly synchronizes with command pulses providing fast positional response. Hi STEP is the optimum choice when zero-speed stability and rapid motions within a short distance are required. Traditional servo motor systems have a natural delay called settling time between the command input signals and the resultant motion because of the constant monitoring of the current position.

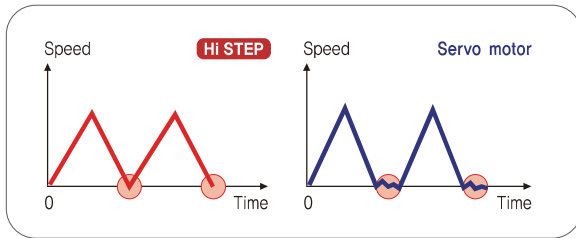

9. High Resolution

The unit of the position command can be divided precisely. (Max. 20,000 pulses/revolution)

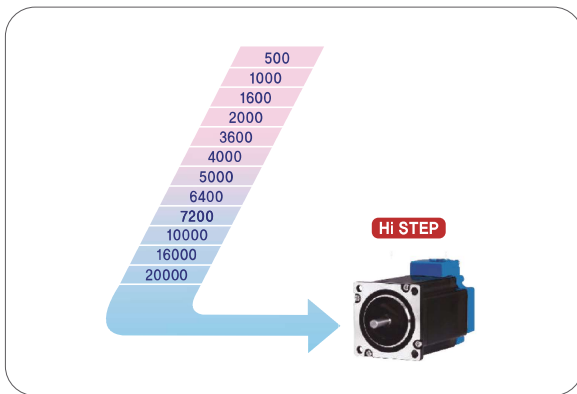

10. High Torque

Compared with common step motors and drives, Hi STEP motion control systems can maintain a high torque state over relatively long period of time. This means that Hi STEP continuously operates without loss of position under 100% of the load. Unlike conventional Microstep drives, Hi STEP exploits continuous high torque operation during high speed motion due to its innovative optimum current phase control.

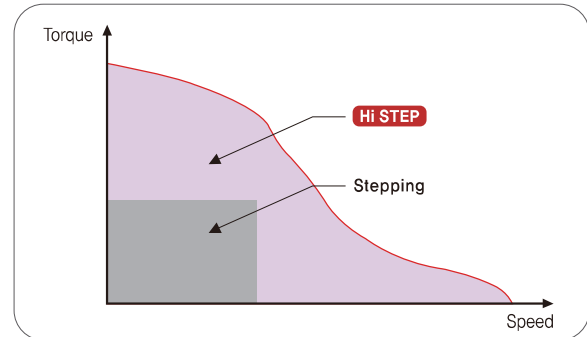

11. High Speed

The Hi STEP operates well at high speed without the loss of synchronism or positioning error.

Hi STEP's ability of continuous current position monitoring of enables the stepping motor to generate high torque, even under a 100% load condition.

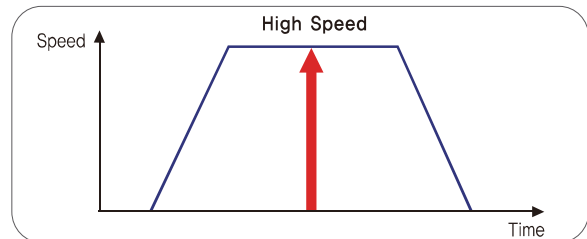

Advantages over Open-Loop Control Stepping Drive

1. Reliable positioning without loss of synchronism.
2. Holding stable position and automatically recovering to the original position even after experiencing positioning error due to external forces, such as mechanical vibration or vertical positional holding.
3. Hi STEP utilizes 100% of the full range of rated motor torque, contrary to a conventional open-loop stepping driver that can use up to 50% of the rated motor torque due to the loss of synchronism.
4. Capability to operate at high speed due to load-dependant current control, open-loop stepping drivers use a constant current control at all speed ranges without considering load variations.

Advantages over Servo Motor Controller

1. No gain tuning. (Automatic gain adjustment in response to a load change)
2. Maintains the stable holding position without oscillation after completion of positioning.
3. Fast positioning due to the independent control by on-board ARM.
4. Continuous operation during rapid short-stroke movement due to instantaneous positioning.

Features of Motion Controller

1. Loop Count

This function allows positioning repeatedly according to the Loop Count Number.

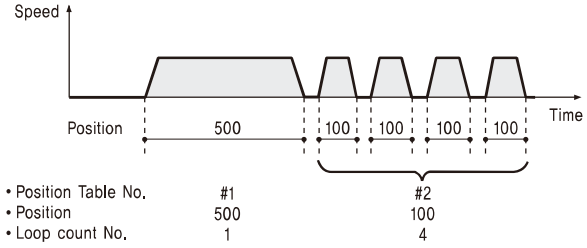

2. Acceleration/Deceleration

For quick acceleration and gradual deceleration, you can set each acceleration and deceleration time separately.

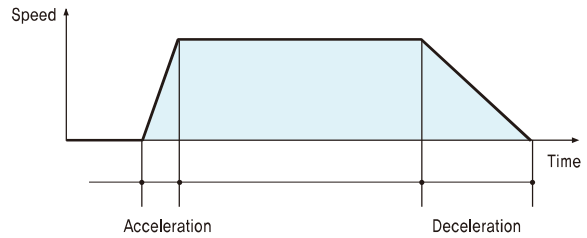

3. Pause

You can pause the motion upon the input of an external signal. When Pause signal change to OFF, the motor will restart to original target position.

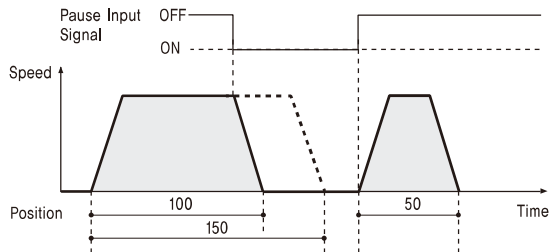

4. Alarm

The number of LED flashing time and information displayed on the 7-Segment indicates which Alarm has occurred.

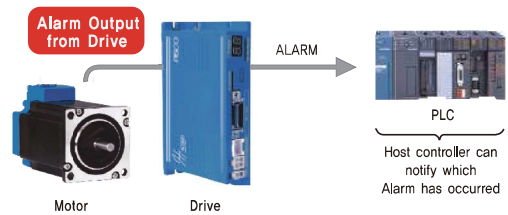

5. Teaching

Teaching signal is used to memorize current Position data into the selected Position Table item.

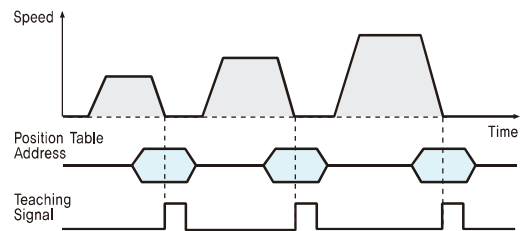

6. Jump

Within one Position Table, you can select various Position Table numbers that you want to jump. With three external input signal during movement, the next jump Position Table number can be select.

■ Position Table #14

Position	---	Next	---	Input 1	Input 2	Input 3	---
10000		100		115	116	117	

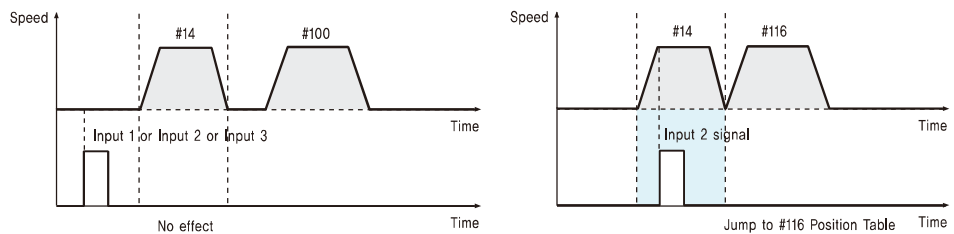

Hi STEP CC-Link Part Numbering

HiSTEP-ECL-56L-A-BK-□

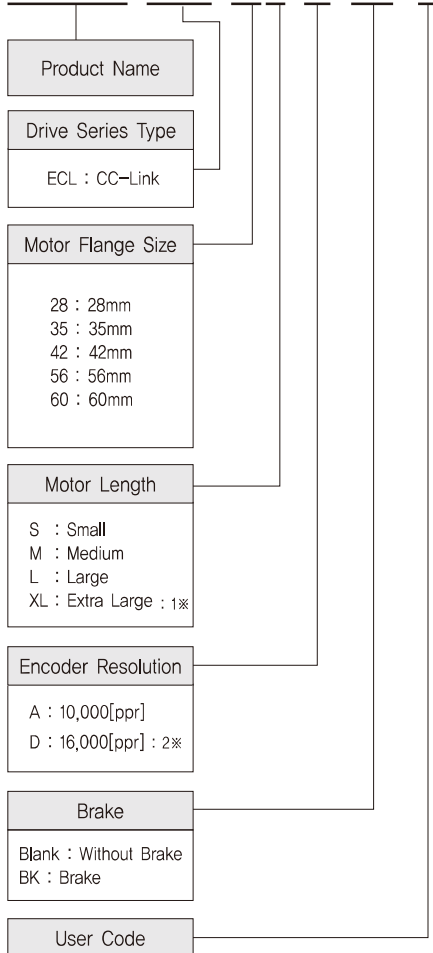

1※ : Motor length XL only 42mm size

2※ : Encoder Resolution 16,000[ppr] only respond 28mm size

Standard Combination

Unit Part Number	Motor Model Number	Drive Model Number
HiSTEP-ECL-28S-D	Hi-EM-28S-D	Hi-ED-CL-28S-D
HiSTEP-ECL-28M-D	Hi-EM-28M-D	Hi-ED-CL-28M-D
HiSTEP-ECL-28L-D	Hi-EM-28L-D	Hi-ED-CL-28L-D
HiSTEP-ECL-35M-A	Hi-EM-35M-A	Hi-ED-CL-35M-A
HiSTEP-ECL-35L-A	Hi-EM-35L-A	Hi-ED-CL-35L-A
HiSTEP-ECL-42S-A	Hi-EM-42S-A	Hi-ED-CL-42S-A
HiSTEP-ECL-42M-A	Hi-EM-42M-A	Hi-ED-CL-42M-A
HiSTEP-ECL-42XL-A	Hi-EM-42XL-A	Hi-ED-CL-42XL-A
HiSTEP-ECL-56S-A	Hi-EM-56S-A	Hi-ED-CL-56S-A
HiSTEP-ECL-56M-A	Hi-EM-56M-A	Hi-ED-CL-56M-A
HiSTEP-ECL-56L-A	Hi-EM-56L-A	Hi-ED-CL-56L-A
HiSTEP-ECL-60S-A	Hi-EM-60S-A	Hi-ED-CL-60S-A
HiSTEP-ECL-60M-A	Hi-EM-60M-A	Hi-ED-CL-60M-A
HiSTEP-ECL-60L-A	Hi-EM-60L-A	Hi-ED-CL-60L-A

Combination with Brake

Unit Part Number	Motor Model Number	Drive Model Number
HiSTEP-ECL-42S-A-BK	Hi-EM-42S-A-BK	Hi-ED-CL-42S-A
HiSTEP-ECL-42M-A-BK	Hi-EM-42M-A-BK	Hi-ED-CL-42M-A
HiSTEP-ECL-42XL-A-BK	Hi-EM-42XL-A-BK	Hi-ED-CL-42XL-A
HiSTEP-ECL-56S-A-BK	Hi-EM-56S-A-BK	Hi-ED-CL-56S-A
HiSTEP-ECL-56M-A-BK	Hi-EM-56M-A-BK	Hi-ED-CL-56M-A
HiSTEP-ECL-56L-A-BK	Hi-EM-56L-A-BK	Hi-ED-CL-56L-A
HiSTEP-ECL-60S-A-BK	Hi-EM-60S-A-BK	Hi-ED-CL-60S-A
HiSTEP-ECL-60M-A-BK	Hi-EM-60M-A-BK	Hi-ED-CL-60M-A
HiSTEP-ECL-60L-A-BK	Hi-EM-60L-A-BK	Hi-ED-CL-60L-A

Specifications of Drive

Motor Model	Hi-EM-28 series	Hi-EM-35 series	Hi-EM-42 series	Hi-EM-56 series	Hi-EM-60 series
Driver Model	Hi-ED-CL-28 series	Hi-ED-CL-35 series	Hi-ED-CL-42 series	Hi-ED-CL-56 series	Hi-ED-CL-60 series
Input Voltage	24VDC \pm 10%				
Control Method	Closed loop control with 32bit MCU				
Current Consumption	Max 500mA (Except motor current)				
Operating Condition	Ambient Temperature	<ul style="list-style-type: none"> In Use: 0~50°C In Storage: -20~70°C 			
	Humidity	<ul style="list-style-type: none"> In Use: 35~85% RH (Non-Condensing) In Storage: 10~90% RH (Non-Condensing) 			
	Vib, Resist.	0.5g			
Function	Rotation Speed	0~3,000 [rpm] ^{*1}			
	Resolution [ppr]	4,000/Rev. Encoder model: 500 1,000 1,600 2,000 3,600 5,000 6,400 7,200 10,000 4,000 10,000/Rev. Encoder model: 500 1,000 1,600 2,000 3,600 5,000 6,400 7,200 10,000 16,000/Rev. Encoder model: 500 1,000 1,600 2,000 3,600 5,000 6,400 7,200 10,000 16,000 20,000/Rev. Encoder model: 500 1,000 1,600 2,000 3,600 5,000 6,400 7,200 10,000 20,000 (Selectable by parameter) ^{*2}			
	Protection Functions	Over Current Error, Over Speed Error, Position Tracking Error, Over Load Error, Over Temperature Error, Over Regenerated Voltage Error, Motor Connect Error, Encoder Connect Error, Motor Voltage Error, In-Position Error, ROM Error, Position Overflow Error			
	LED Display	Power status, Alarm status, In-Position status, Servo On status			
	In-Position Selection	0~63 (Selectable by parameter)			
	Position Gain Selection	0~63 (Selectable by parameter)			
	Rotational Direction	CW/CCW (Selectable by parameter)			
CC-Link	Station Type	Remote Device Station			
	Number of Occupied Station	1 station, 2 station			
I/O Signal	Input Signals	3 dedicated inputs (LIMIT+, LIMIT-, ORIGIN), 7 programmable inputs (Photocoupler)			
	Output Signals	6 programmable outputs (Photocoupler), Brake			

*1 : Up to the resolution of 10,000[ppr], maximum speed can be reached by 3,000[rpm] and with the resolution more than 10,000[ppr], maximum speed shall be reduced accordingly.

*2 : When selected resolution is more than encoder resolution, motor shall be operated by microstep between pulses.

Dimensions of Drive [mm]

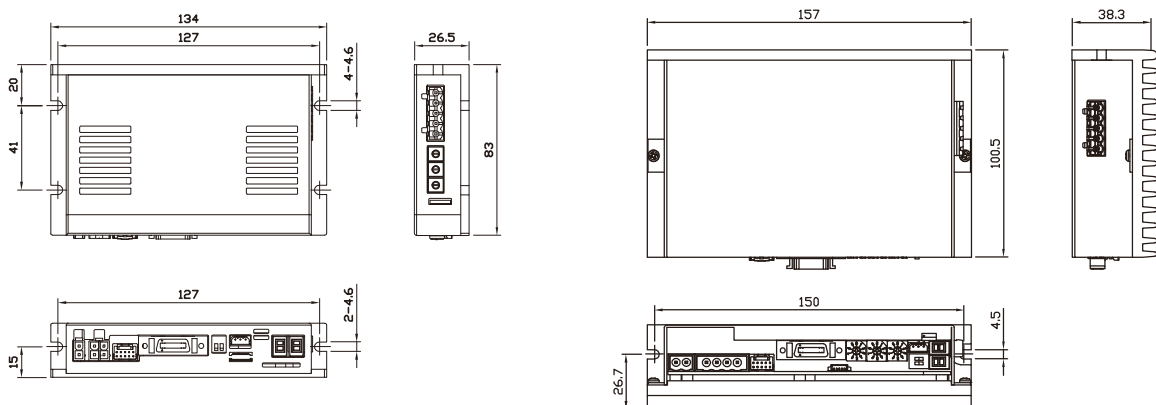

Specifications of Moter

MODEL	UNIT	Hi-EM-28 series			Hi-EM-35 series		Hi-EM-42 series		
		28S	28M	28L	35M	35L	42S	42M	42XL
DRIVE METHOD	-	BI-POLAR							
NUMBER OF PHASES	-	2	2	2	2	2	2	2	2
VOLTAGE	VDC	3,0	3,0	3,0	2,88	4,59	3,36	4,32	7,2
CURRENT per PHASE	A	0,95	0,95	0,95	0,6	0,85	1,2	1,2	1,2
RESISTANCE per PHASE	Ohm	3,2	3,2	3,2	4,8	5,4	2,8	3,6	6,0
INDUCTANCE per PHASE	mH	2,0	2,7	3,2	6,1	6,5	5,4	7,2	15,6
HOLDING TORQUE	N·m	0,069	0,098	0,118	0,05	0,176	0,32	0,44	0,65
ROTOR INERTIA	g·cm ²	9,0	13	18	8	11	35	54	114
WEIGHTS	g	110	140	200	120	200	250	280	500
LENGTH(L)	mm	32	45	50	26	38	34	40	60
PERMISSIBLE OVERHUNG LOAD (DISTANCE FROM END OF SHAFT)	3mm	N	30	30	30	22	22	22	22
	8mm		38	38	38	26	26	26	26
	13mm		53	53	53	33	33	33	33
	18mm		-	-	-	46	46	46	46
PERMISSIBLE THRUST LOAD	N	Lower than motor weight							
INSULATION RESISTANCE	Mohm	100 MIN.(at 500VDC)							
INSULATION CLASS	-	CLASS B(130°C)							
OPERATING TEMPERATURE	°C	0 to 55							

MODEL	UNIT	Hi-EM-56 series			Hi-EM-60 series			
		56S	56M	56L	60S	60M	60L	
DRIVE METHOD	-	BI-POLAR						
NUMBER OF PHASES	-	2	2	2	2	2	2	
VOLTAGE	VDC	1,56	1,62	2,64	1,32	1,48	2,2	
CURRENT per PHASE	A	3,0	3,0	3,0	4,0	4,0	4,0	
RESISTANCE per PHASE	Ohm	0,52	0,54	0,88	0,33	0,37	0,55	
INDUCTANCE per PHASE	mH	1,2	2,0	4,0	0,75	1,1	2,7	
HOLDING TORQUE	N·m	0,64	1,0	1,5	0,88	1,28	2,4	
ROTOR INERTIA	g·cm ²	180	280	520	240	490	690	
WEIGHTS	g	500	720	1150	600	1000	1300	
LENGTH(L)	mm	46	55	80	47	56	85	
PERMISSIBLE OVERHUNG LOAD (DISTANCE FROM END OF SHAFT)	3mm	N	52	52	52	70	70	70
	8mm		65	65	65	87	87	87
	13mm		85	85	85	114	114	114
	18mm		123	123	123	165	165	165
PERMISSIBLE THRUST LOAD	N	Lower than motor weight						
INSULATION RESISTANCE	Mohm	100 MIN.(at 500VDC)						
INSULATION CLASS	-	CLASS B(130°C)						
OPERATING TEMPERATURE	°C	0 to 55						

Torque Characteristics of Motor

HiSTEP-ECL-28 series

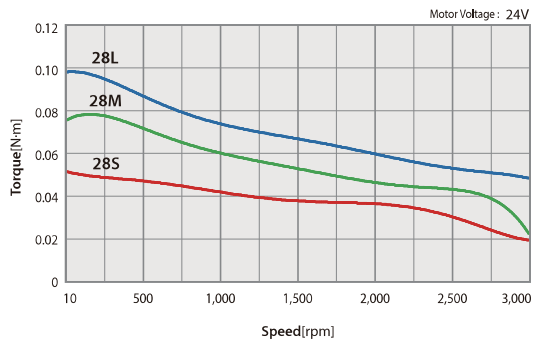

HiSTEP-ECL-35 series

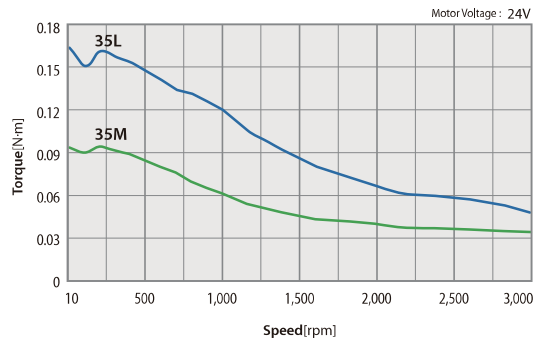

HiSTEP-ECL-42 series

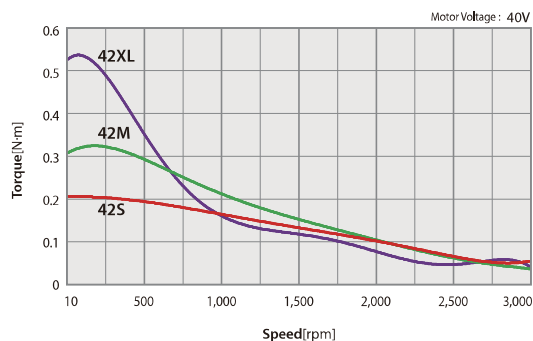

HiSTEP-ECL-56 series

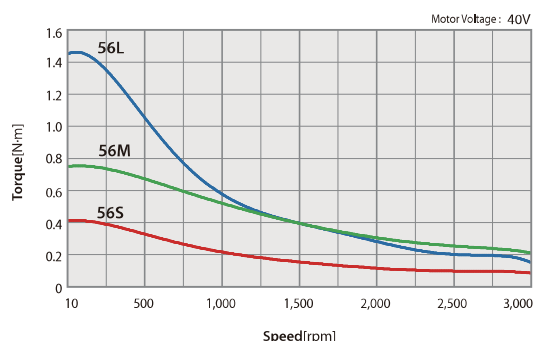

HiSTEP-ECL-60 series

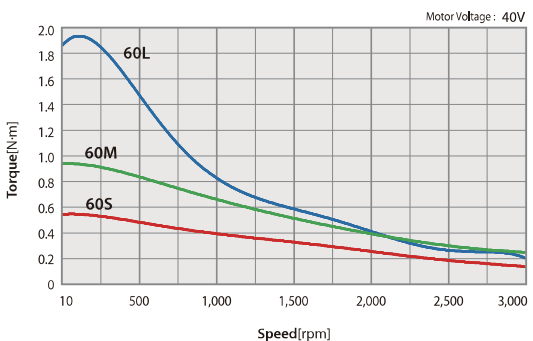

Dimensions of Motor [mm]

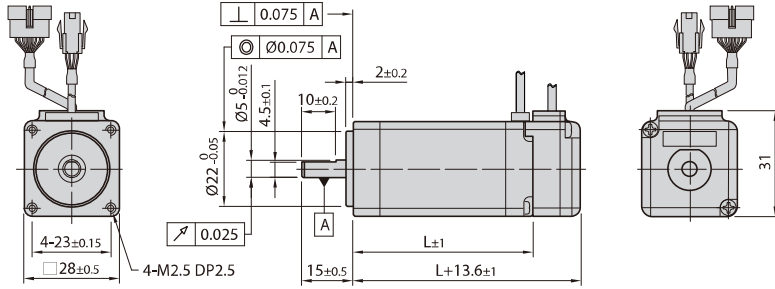

28mm

Model name	Length(L)
Hi-EM-28S	32
Hi-EM-28M	45
Hi-EM-28L	50

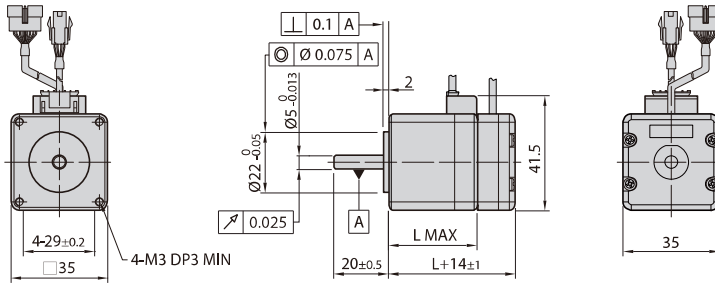

35mm

Model name	Length(L)
Hi-EM-35M	32
Hi-EM-35L	36

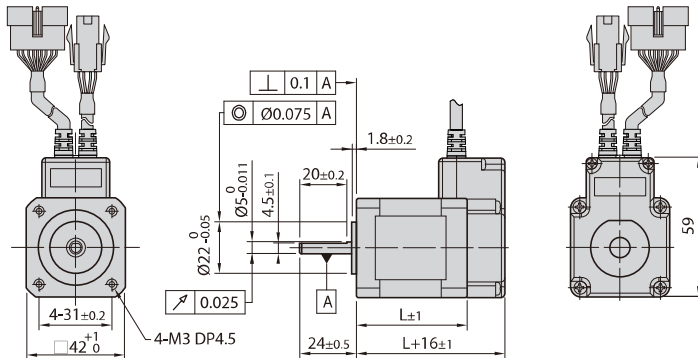

42mm

Model name	Length(L)
Hi-EM-42S	34
Hi-EM-42M	40
Hi-EM-42XL	60

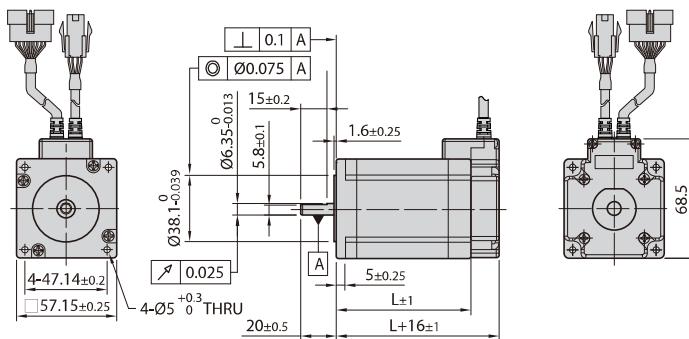

56mm

Model name	Length(L)
Hi-EM-56S	46
Hi-EM-56M	55
Hi-EM-56L	80

※ There are 2 kinds size of front shaft diameter for Hi-EM-56 series as Ø6,35 and Ø8,0.

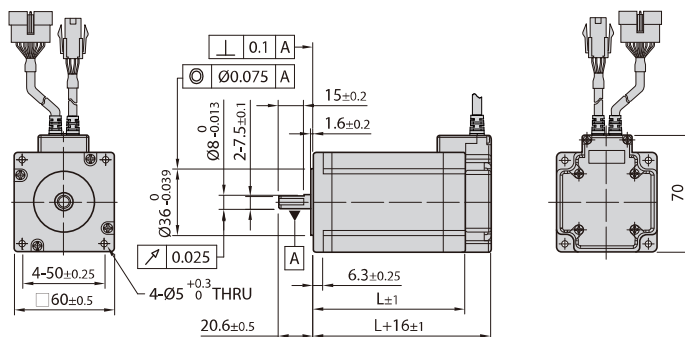

60mm

Model name	Length(L)
Hi-EM-60S	47
Hi-EM-60M	56
Hi-EM-60L	85

Specifications of Motor with Brake

Unit Part Number	Motor Model Number	Electronic Brake					Motor Unit Weight [g]	Permitted Overhung Load [N]				Permitted Thrust Load [N]
		Type	Voltage Input [V]	Rated Current [A]	Power Consumption [W]	Statical Friction Torque [N·m]		Length from Motor Point [mm]				
								3	8	13	18	
HiSTEP-CL-42S-■-BK	Hi-EM-42S-■-BK	Non-excitation run Type	24VDC ±10%	0,2	5	0,2	510	22	26	33	46	Must be Lower than Unit's Weight
HiSTEP-CL-42M-■-BK	Hi-EM-42M-■-BK						570					
HiSTEP-CL-42XL-■-BK	Hi-EM-42XL-■-BK						770					
HiSTEP-CL-56S-■-BK	Hi-EM-56S-■-BK			1030	52	65	85	123				
HiSTEP-CL-56M-■-BK	Hi-EM-56M-■-BK			1190								
HiSTEP-CL-56L-■-BK	Hi-EM-56L-■-BK			1630								
HiSTEP-CL-60S-■-BK	Hi-EM-60S-■-BK			1150	70	87	114	165				
HiSTEP-CL-60M-■-BK	Hi-EM-60M-■-BK			1350								
HiSTEP-CL-60L-■-BK	Hi-EM-60L-■-BK			1960								

- * The code of encoder resolution will be marked in "■"
- * Electronic Brake cannot be used for braking, Position hold purpose only when power OFF.
- * The weight means Motor Unit Weight including Motor and Electronic Brake.
- * Motor Model Number is combined model name of Motor and Brake.
- * Motor specification and torque characteristic are same as Standard Motor.

* Brake Operation Timing Chart

Hi STEP CC-Link controls Brake by Drive automatically.
Please refer to below Timing Chart when Brake is controlled by the upper controller other than using Hi STEP CC-Link Brake control, Otherwise, Drive malfunctioning and loads can be fall down.
Also, please do not operate Brake while motor operation to prevent damage.

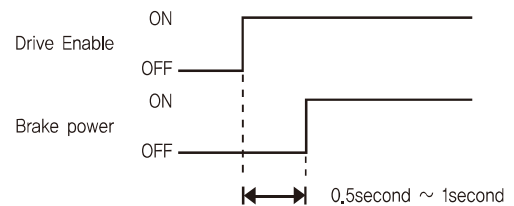

Dimensions of Motor With Brake [mm]

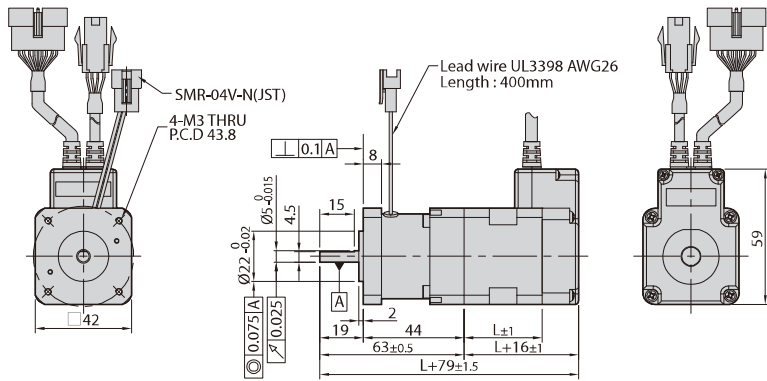

42mm

Model Name	Length(L)	Weight(kg)
Hi-EM-42S	34	0,51
Hi-EM-42M	40	0,57
Hi-EM-42XL	60	0,77

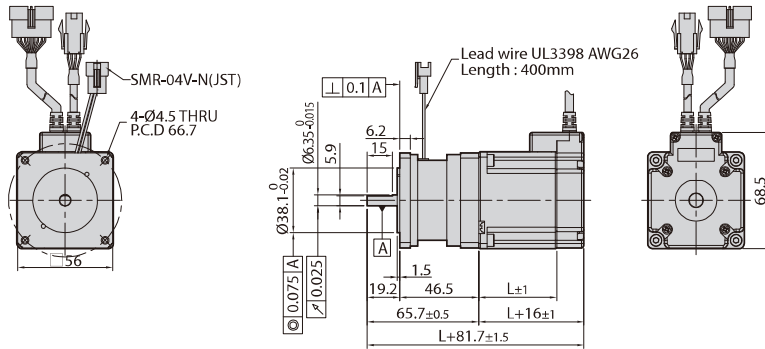

56mm

Model Name	Length(L)	Weight(kg)
Hi-EM-56S	46	1,03
Hi-EM-56M	55	1,19
Hi-EM-56L	80	1,63

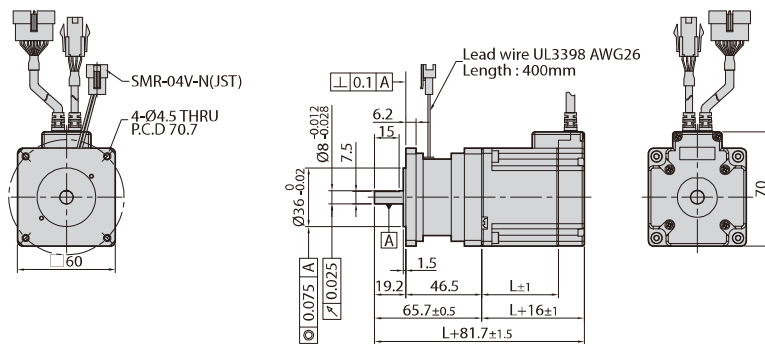

60mm

Model Name	Length(L)	Weight(kg)
Hi-EM-60S	47	1,15
Hi-EM-60M	56	1,35
Hi-EM-60L	85	1,96

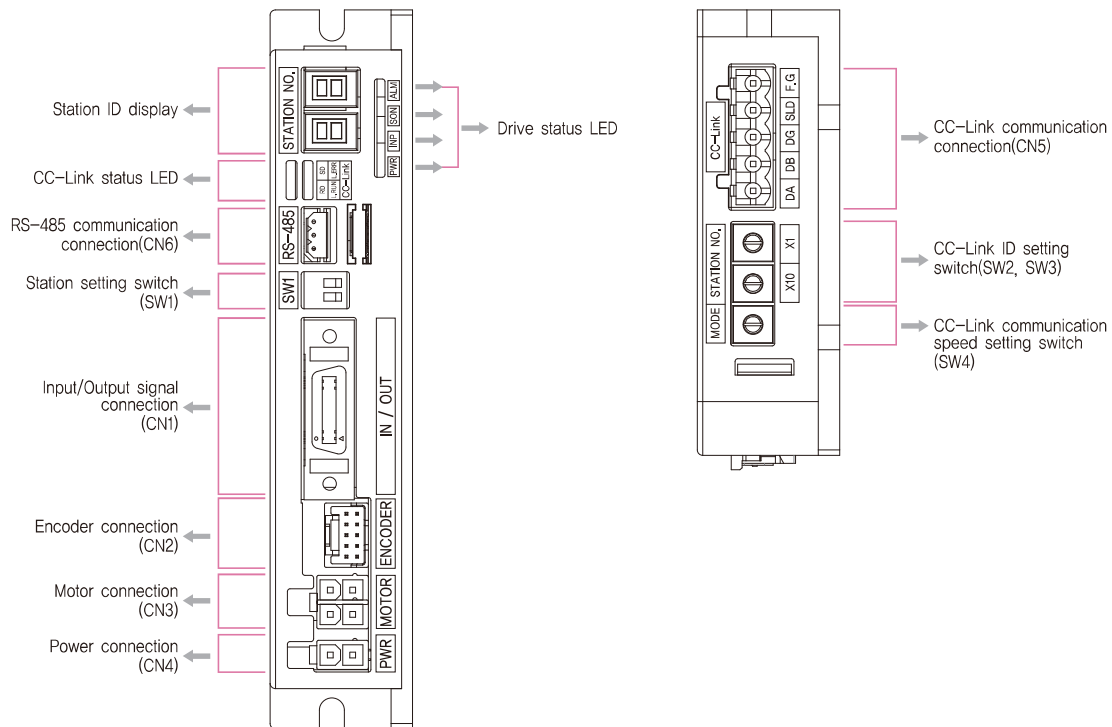

1. Drive Status LED

Indication	Color	Function	ON/OFF Condition
PWR	Green	Power Input Indication	LED is turned ON when power is applied
INP	Yellow	Complete Positioning Motion	Lights On when Positioning error reaches within the preset pulse selected by parameter
SON	Orange	Servo On / Off Indication	Servo On: Lights On, Servo Off: Lights Off
ALM	Red	Alarm indication	Flash when protection function is activated

■ Protection functions and LED flash times

Times	Error Code ^{*4}	Protection	Conditions
1	E-□01	Over Current Error	The current through power devices in inverter exceeds the limit value ^{*1}
2	E-□02	Over Speed Error	Motor speed exceeds 3,000 [rpm]
3	E-□03	Position Tracking Error	Position error value is higher than 180° in motor run state ^{*2}
4	E-□04	Over Load Error	The motor is continuously operated more than 5 seconds under a load exceeding the max _n torque
5	E-□05	Over Temperature Error	Temperature of inside of drive exceed 85°C
6	E-□06	Over Regenerated Voltage Error	Back-EMF is higher than limit value ^{*3}
7	E-□07	Motor Connect Error	The power is ON without connection of the motor cable to drive
8	E-□08	Encoder Connect Error	Cable connection error in Encoder connection of drive
10	E-□0A	In-Position Error	After operation is finished, a position error occurs
12	E-□0C	ROM Error	Error occurs in parameter storage device(ROM)
15	E-□0F	Position Overflow Error	Position error value is higher than 180° in motor stop state ^{*2}

*1 : Limit value depends on motor model, (Refer to the Manual)

*2 : Default value can be changed by parameter, (Refer to the Manual)

*3 : Voltage limit of Back-EMP depends on motor model, (Refer to the Manual)

*4 : When an alarm occurs, error code is displayed on the 7-segment instead of CC-Link ID.

※ Please refer to the Manual for the details of protection functions.

※ □ is the CC-Link error code.



Alarm LED flash
(Ex, Position tracking error)

2. CC-Link Status LED

Name	Color	Status	Function	Explanation
L_RUN	Green	Off	Power Off	Checking the power status,
			No network connection	Checking the status of the network cable and Master controller,
		On	Normal operation	CC-Link network connection is normal status,
L_ERR	Red	Off	Normal operation	No error occurred
			Critical error	Communication process fails,
		Flashing	Communication error	Error occurred in the CC-Link network, Check the 7-segment display information and process it,
			CRC error, Network cable error	There is a contact error of the network connector or noise in the cable line. To Check the terminating resistor attachment status, network wiring and the grounding status of the frame,
RD	Orange	Off	No Data receiving	
		On	Data receiving	
SD	Yellow	Off	No Data transmissiOn	
		On	Data transmitting	

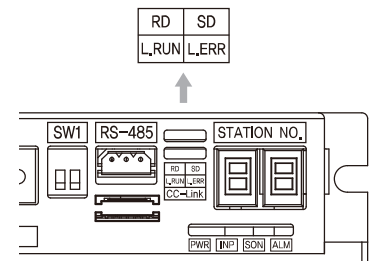

■ CC-Link network status 7-segment display information

Error Code	Description
E-0□□.	Normal CC-Link network status
E-1□□.	CC-Link station number switch setting is incorrect
E-2□□.	CC-Link mode switch setting is incorrect
E-3□□.	CC-Link station number switch setting is changed
E-4□□.	CC-Link mode switch setting is changed
E-5□□.	CRC error occurs in CC-Link communication
E-6□□.	Timeout occurs during communication with master
E-7□□.	Communication with master is disconnected
E-8□□.	CC-Link Processor Error 1
E-9□□.	CC-Link Processor Error 2
E-A□□.	Data link error
E-B□□.	Remote I/O error
E-C□□.	Remote register error

※ □□ is the drive error code.

3. CC-Link Station Display and Setting Switch(SW2, SW3)

There are two Rotary switch to set value of CC-Link station No, Switch on the right side(x1) indicates the one's(1) digit and Switch on the left side(x10) indicates ten's(10) digit.

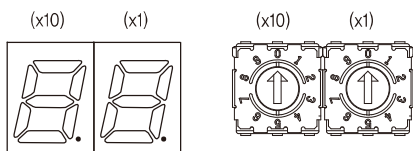

※ Default setting is '00'

4. CC-Link Communication Speed Setting Switch(SW4)

This is a switch to set communication speed of CC-Link, (The case of the product is marked with 'MODE'.)

MODE	CC-Link Baud Rate
0	156 kbps ^{*1}
1	625 kbps
3	2,5 Mbps
4	5 Mbps
5	10 Mbps
6	NONE
7	NONE
8	NONE
9	NONE

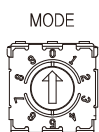

*1 : Defaule = 156kbps

5. CC-Link Station Setting Switch(SW1)

Hi STEP CC-Link provides various functions depending on the station occupancy. Select the station occupancy with Dip-switch(SW1).

SW1,1	SW1,2	Occupation
OFF	OFF	1 station occupation ^{*1}
ON	OFF	2 station occupation



*1 : Defaule = '1 station occupation'

6. Input/Output Signal Connector(CN1)

NO.	Function	I/O
1	LIMIT+	Input
2	LIMIT-	Input
3	ORIGIN	Input
4	Digital In1	Input
5	Digital In2	Input
6	Digital In3	Input
7	Digital In4	Input
8	Digital In5	Input
9	Digital In6	Input
10	Digital In7	Input
11	Digital Out1	Output
12	Digital Out2	Output
13	Digital Out3	Output
14	Digital Out4	Output
15	Digital Out5	Output
16	Digital Out6	Output
17	BRAKE+	Output
18	BRAKE-	Output
19	EXT_GND	Input
20	EXT_24VDC	Input

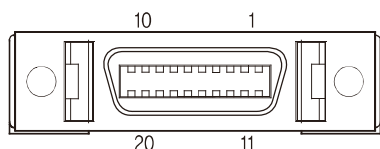

9. Power Connector(CN4)

NO.	Function	I/O
1	24VDC	Input
2	GND	Input

NO.	Function	I/O
1	GND	Input
2	40~70VDC	Input



10. CC-Link Communication Connector(CN5)

NO.	Function
1	DA
2	DB
3	DG
4	SLD
5	F_GND

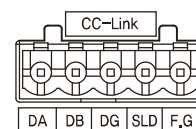

7. Encoder Connector(CN2)

NO.	Function	I/O
1	A+	Input
2	A-	Input
3	B+	Input
4	B-	Input
5	Z+	Input
6	Z-	Input
7	5VDC	Output
8	GND	Output
9	F_GND	----
10	F_GND	----

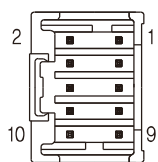

12. RS-485 Communication Connector(CN6)

NO.	Function
1	Data+
2	Data-
3	GND

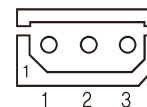

8. Motor Connector(CN3)

NO.	Function	I/O
1	A Phase	Output
2	B Phase	Output
3	/A Phase	Output
4	/B Phase	Output



NO.	Function	I/O
1	/B Phase	Output
2	B Phase	Output
3	/A Phase	Output
4	A Phase	Output

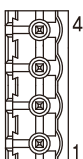

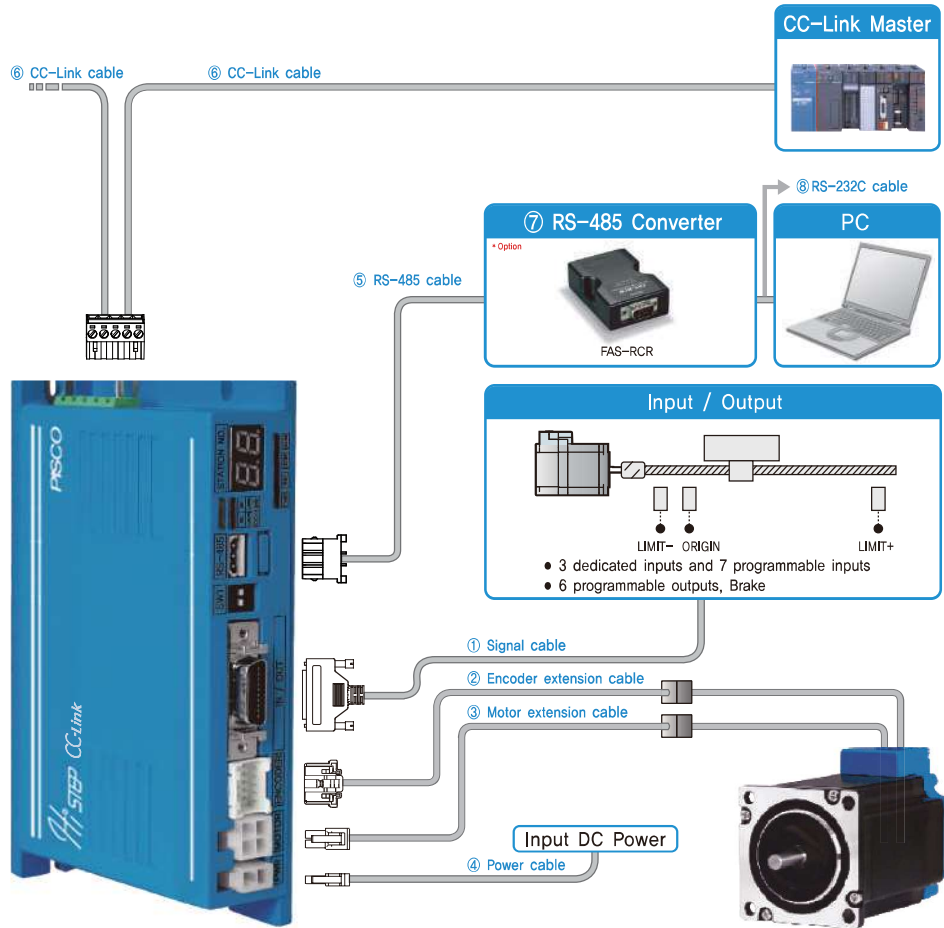

Type	Signal Cable	Encoder Cable	Motor Cable	Power Cable	CC-Link Cable	RS-485 Cable
Length supplied	—	30cm	30cm	—	—	—
Max. Length	20m	20m	20m	2m	100m	2m

1. Options

① Signal Cable

Available to connect between Input/Output signals and Hi STEP CC-Link.

Item	Length [m]	Remark
CSVN-S-□□□F	□□□	Normal Cable
CSVN-S-□□□M	□□□	Robot Cable

□ is for Cable Length, The unit is 1m and Max, 20m length.

② Encoder Extension Cable

Available to extended connection between Encoder and Hi STEP CC-Link.

Item	Length [m]	Remark
CSVO-E-□□□F	□□□	Normal Cable
CSVO-E-□□□M	□□□	Robot Cable

□ is for Cable Length, The unit is 1m and Max, 20m length.

③ Motor Extension Cable

Available to extended connection between motor and Hi STEP CC-Link.

Item	Length [m]	Remark
CSVO-M-□□□F	□□□	Normal Cable
CSVO-M-□□□M	□□□	Robot Cable

□ is for Cable Length, The unit is 1m and Max, 20m length.

④ Power Cable

Available to connect between Power and Hi STEP CC-Link.

Item	Length [m]	Remark
CSVO-P-□□□F	□□□	Normal Cable
CSVO-P-□□□M	□□□	Robot Cable

□ is for Cable Length, The unit is 1m and Max, 2m length.

⑤ RS-485 Cable

Hi STEP CC-Link RS-485 network,

Item	Length [m]	Remark
CGNR-RT-□□□F	□□□	Normal Cable

□ is for Cable Length, The unit is 1m and Max, 2m length.

⑥ CC-Link Network Cable

It is a cable to connect Hi STEP CC-Link to CC-Link network.

* This cable is not provided and it is recommended to use the cable specified by CC-Link Association.

⑦ FAS-RCR(RS-232C to RS-485 Converter)

Item	Specification
Comm, Speed	Max, 115,2 [kbps]
Comm, Distance	RS-232C: Max, 15m RS-485: Max, 1,2km
Connection Type	RS-232C: DB9 Female RS-485: RJ-45
Dimension	50×75×23mm
Weight	38g
Power	Powered from PC (Usable for external DC5~24V)

⑧ RS-232C Cable

Available to connect between RS-232C port of master and FAS-RCR.

Item	Length [m]	Remark
CGNR-C-002F	2	Normal Cable
CGNR-C-003F	3	
CGNR-C-005F	5	

⑨ TB-Plus(Interface Board)

Available to connect more conveniently between Input/Output signal and Hi STEP CC-Link.

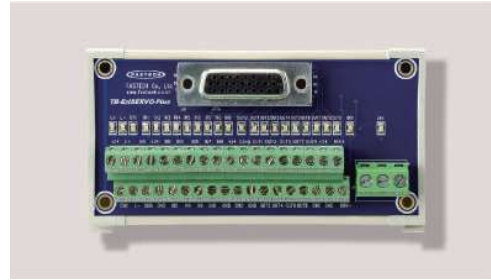

⑩ Interface Cable

Available to Connect between TB-Plus Interface Board and Hi STEP CC-Link.

Item	Length [m]	Remark
CIFN-S-□□□F	□□□	Normal Cable
CIFN-S-□□□M	□□□	Robot Cable

□ is for Cable Length, The unit is 1m and Max, 20m length.

2. Connector Specifications

Connector specifications for cabling to drive.

Purpose		Item	Part Number	Manufacturer
Power (CN4)		Housing Terminal	5557-02R 5556T	MOLEX
Motor	Drive Side (CN3)	Housing Terminal	5557-04R 5556T	MOLEX
	Motor Side	Housing Terminal	5557-04R 5556T	MOLEX
Encoder	Drive Side (CN2)	Housing Terminal	51353-1000 56134-9000	MOLEX
	Encoder Side	Housing Terminal	SMP-09V-NC SHF-001T-0,8BS	JST
Signal (CN1)		Connector Backshell	10120-3000PE 10320-52A0-008	3M
CC-Link Communication (CN5)		Terminal Block	AK950-5	PTR
RS-485 Communication (CN6)		Housing Terminal	5264-03 5263PBT	MOLEX

※ Above Connector is the most suitable product for the drive applied. Another equivalent Connector can be used.

External Wiring Diagram

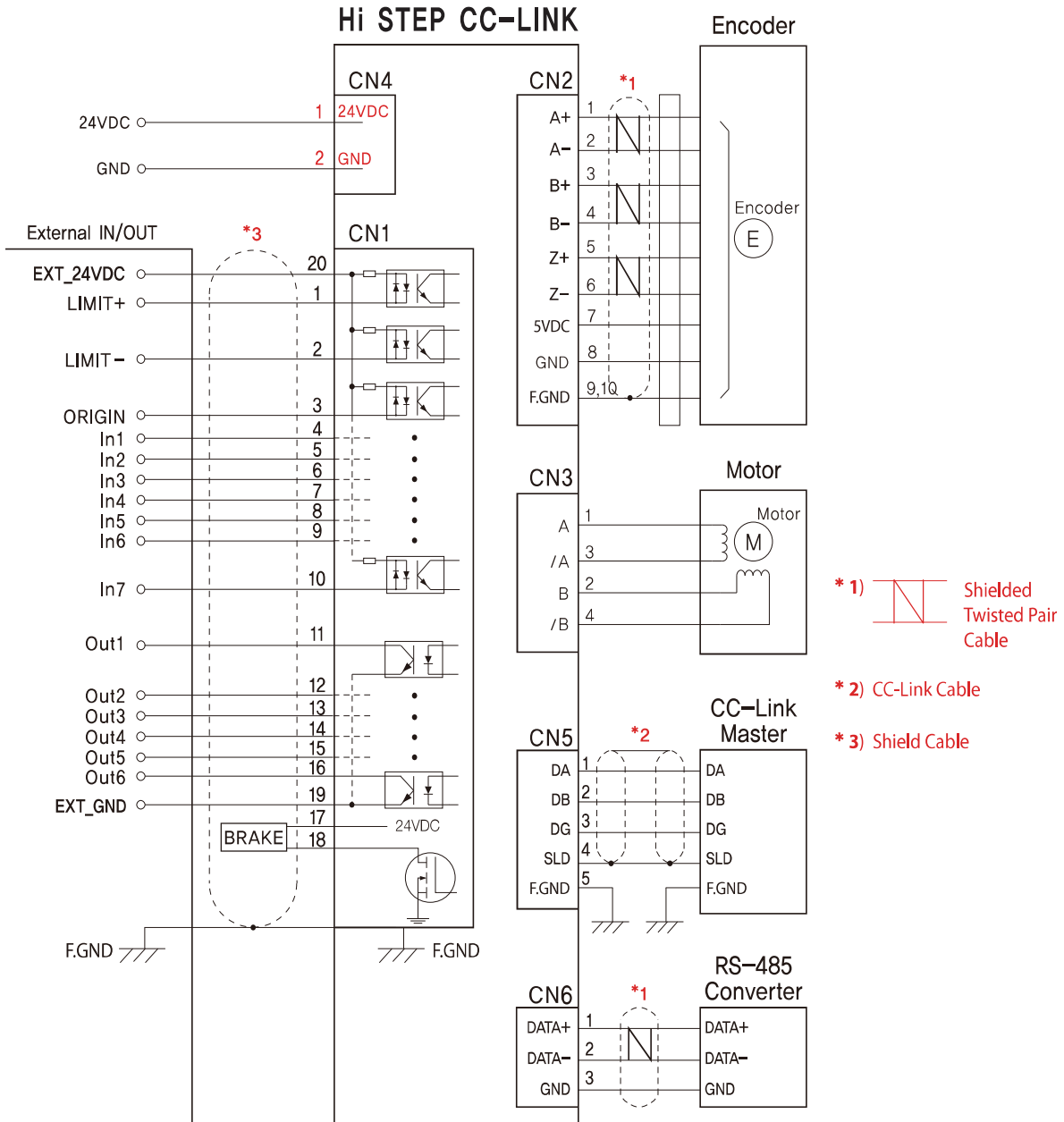

※ When connects I/O cable between controller and drive, please turn off the power of both controller and drive, in order to protect the drive from any damage.

CAUTION

Please refer to the Manual when connects motor extension cable.
Careful connection will be required to protect the drive from any damages.