

Ezi-SPEED[®]

BLDC Motor Speed Control System

- AC Input (110V, 220V) **BLDC Motor Speed Control System**
- Wide Speed Control Range(**50~4000rpm**)
- **Stable Speed Control** by Vector Control(**Speed Regulation 0.2%**)
- **Stable Low Speed(50rpm)** by Velocity Observer
- High Efficiency with Low Heat Generation
- Easy Speed Control, Easy Wiring and Connecting(Front Panel and I/O)
- Product Line-Up : **30, 60, 120, 200, 400W**

Full Digital



CE

FASTECH

Fast, Accurate, Smooth Motion



Fast, Accurate, Smooth Motion

Ezi-SPEED[®]

BLDC Motor Speed Control System



1 Stable Speed Control

(Speed Regulation 0.2%)

Ezi-SPEED compares the setting speed with the speed feedback signals from the motor at all time, and adjusts the motor current using vector control algorithm. So, even if the load changes, stable rotation is maintained from low speed to high speed. Inverter controlled AC induction motor does not perform feedback control, so the speed will be reduced significantly when load increases.

Ezi-SPEED is recommended for applications that require stable speed.

— Speed measuring value

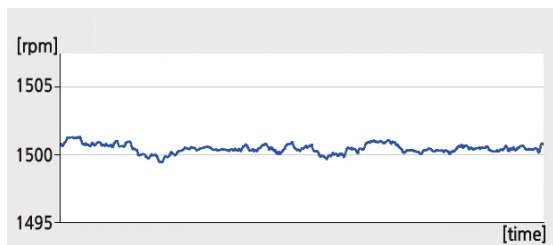

Ezi-SPEED 120W

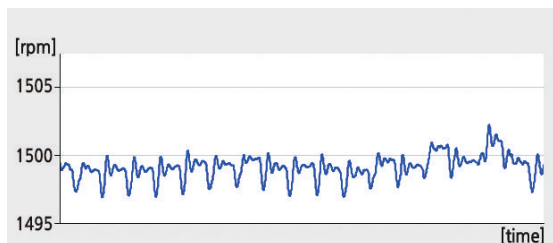

Inverter + AC induction motor 100W

* Load factor: 95% * Setting speed: 1,500 [rpm]
* Resolution of external encoder for measuring velocity ripple : 32,000 [ppr]

2 Wide Speed Control Range

(Speed Ratio: 1:80)

Ezi-SPEED has wide speed control range compared to AC induction motor with inverter. Because torque is not restricted at low speed, Ezi-SPEED is recommended for application that requires stable torque over from low to high speed.

Product	Speed Control Range	Speed Ratio
Ezi-SPEED	50~4,000 [rpm]	1:80
Inverter + AC induction motor	200~2,400 [rpm]	1:12

* Speed range of Inverter + AC induction motor varies depending on model type.

3 High Efficiency

(Energy Savings)

Unlike AC induction motors, BLDC motors use permanent magnets in the rotor so that it could prevent secondary loss from rotor.

Therefore, BLDC motors has higher efficiency than inverter controlled AC induction motor so that customers can save energy.

- Load factor : 100%, Setting speed: 1,500 [rpm]
- Comparison of motor temperature after 4 hours continuous operation.

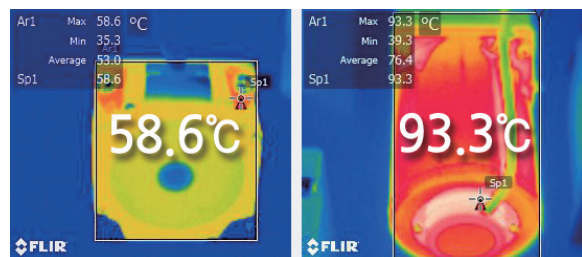

Ezi-SPEED 60W

AC Induction Motor 60W

4 Compact, Light Weight, High Power

Compared to AC induction motor, BLDC motor has compact size, light weight and high power because of the permanent magnets in the rotor.



Ezi-SPEED 60W

AC Induction Motor 60W

5 Easy Wiring

The motor and sensor connector can be easily connected to drive. There is no need for soldering or special tools when connecting the power and I/O cables. For power connector, just insert the lead wire and fix using screw driver. For IO connector, just insert the lead wire while pushing the orange button.



Motor Connector Wiring

8 Display Load Factor and Actual Speed

Load factor is displayed as percentage like 100% for rated torque. User can check the load during operating the motor and can maintain the motor in optimal condition by checking load changes due to the secular change. Also the actual speed can be displayed. (Motor speed, Gearbox speed, Linear speed)



Indication at load factor of 100%



Actual speed at setting speed of 1,500 [rpm]

6 Easy to Use

(Front Panel)

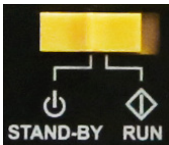



- Control of Operation and Stop
The motor starts when switch is in the "RUN" position, and stops after deceleration when it is moved to the "STAND-BY" position.



- Control of rotation direction
Changing the rotation direction is possible with the rotation direction switch. Changing the rotation to Forward or Reverse direction.



- Control of Speed
The speed control buttons allow you to use simple speed control and many functions. Pushing  button increases the speed and pushing  button reduces the speed. When the desired speed is reached, simply push the  button to set the speed value.

9 8-Speed Settings

8 steps speed operation can be done by setting No.0 ~ No.7 data using inputs P0, P1, P2. We can do this only with Ezi-SPEED without any extra controller.

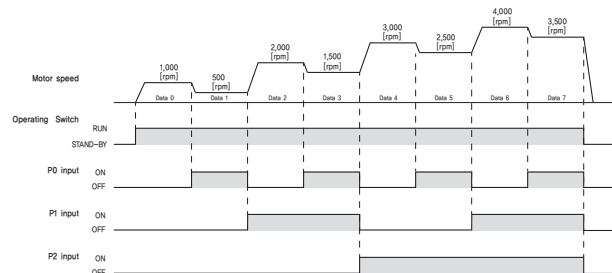

10 Various Functions can be Set on the Drive

- Motor Start/Stop
- Setting the operation speed
- Changing the rotation direction
- Changing the indication
- Operation speed indication when the speed decreasing or increasing ratio is set
- Setting the acceleration/deceleration time
- Button operation lock
- Speed setting for 8-speed operation
- Speed limits setting
- Validating the external operation signals
- External I/O signal allocation
- Setting the overload alarm detection time

7 Operation by External I/O

External I/O can control Start/Stop, Changing rotation direction and Multi speed operation.





Ezi-SPEED

I/O operation



PLC

11 Lock the Setting and Operation

- Ezi-SPEED provides a lock function to prevent unwanted changes in the speed. We cannot change speed or data when it is in lock state.
- **Activating the lock function**
Press the  button for 5 seconds or more when "STAND-BY" mode.
When "LOCK" appears, the lock function is activated.
- **Deactivating the lock function**
Press the  button for 5 seconds or more.
When "UnLk" appears, the lock function is cancelled.

12 Protection Function

- Ezi-SPEED detects abnormal situations like overload, over voltage etc. When this happens, the operation is stopped and an alarm is displayed.
- A regenerative resistor can be used when the deceleration time is short or when a large inertia load is used. Also, the protection function can be activated for the excessive external force acting on the motor shaft.

● Ezi-SPEED Part Numbering

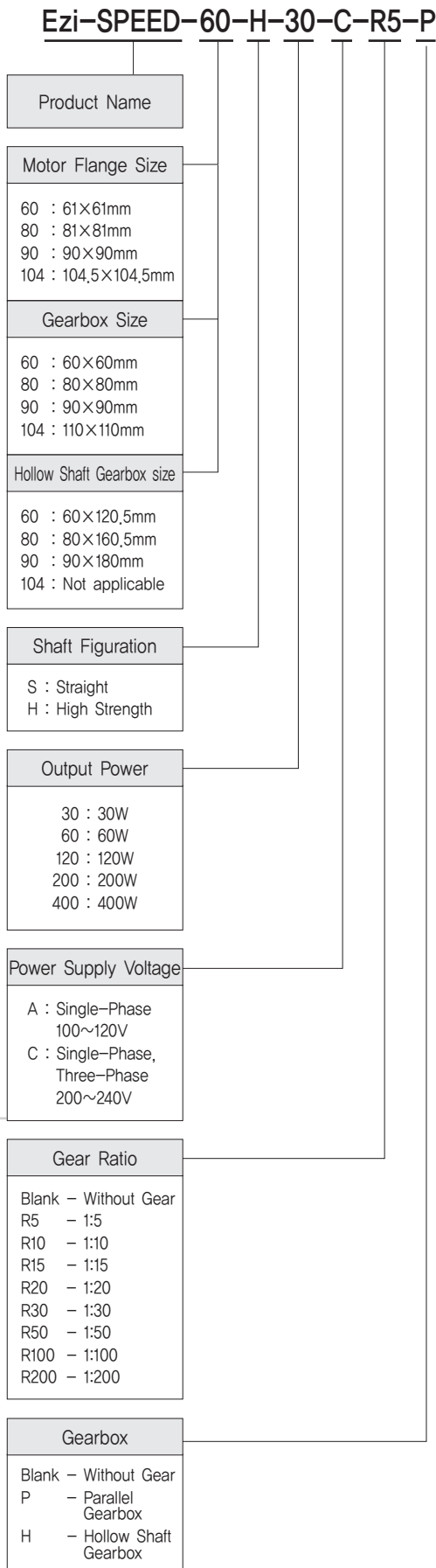

● Standard Combination

Output Power	Unit Part Number	Motor Model Number	Drive Model Number
30W	Ezi-SPEED-60-S-30-A	ESM-60-S-30	ESD-30-A
	Ezi-SPEED-60-S-30-C		ESD-30-C
60W	Ezi-SPEED-80-S-60-A	ESM-80-S-60	ESD-60-A
	Ezi-SPEED-80-S-60-C		ESD-60-C
120W	Ezi-SPEED-90-S-120-A	ESM-90-S-120	ESD-120-A
	Ezi-SPEED-90-S-120-C		ESD-120-C
200W	Ezi-SPEED-104-S-200-C	ESM-104-S-200	ESD-200-C
400W	Ezi-SPEED-104-S-400-C	ESM-104-S-400	ESD-400-C

● Combination with Gearbox

Output Power	Unit Part Number	Motor Model Number	Drive Model Number	Gearbox Model Number	Gear Ratio
30W	Ezi-SPEED-60-H-30-A-R5-P	ESM-60-H-30	ESD-30-A	ESG-60-H-R5-P	1:5
	Ezi-SPEED-60-H-30-C-R5-P		ESD-30-C		
	Ezi-SPEED-60-H-30-A-R5-H		ESD-30-A	ESG-60-H-R5-H	1:10
	Ezi-SPEED-60-H-30-C-R5-H		ESD-30-C		
	Ezi-SPEED-60-H-30-A-R10-P		ESD-30-A	ESG-60-H-R10-P	1:15
	Ezi-SPEED-60-H-30-C-R10-P		ESD-30-C		
	Ezi-SPEED-60-H-30-A-R10-H		ESD-30-A	ESG-60-H-R10-H	1:20
	Ezi-SPEED-60-H-30-C-R10-H		ESD-30-C		
	Ezi-SPEED-60-H-30-A-R15-P		ESD-30-A	ESG-60-H-R15-P	1:30
	Ezi-SPEED-60-H-30-C-R15-P		ESD-30-C		
	Ezi-SPEED-60-H-30-A-R15-H		ESD-30-A	ESG-60-H-R15-H	1:50
	Ezi-SPEED-60-H-30-C-R15-H		ESD-30-C		
	Ezi-SPEED-60-H-30-A-R20-P		ESD-30-A	ESG-60-H-R20-P	1:100
	Ezi-SPEED-60-H-30-C-R20-P		ESD-30-C		
	Ezi-SPEED-60-H-30-A-R20-H		ESD-30-A	ESG-60-H-R20-H	1:150
	Ezi-SPEED-60-H-30-C-R20-H		ESD-30-C		
	Ezi-SPEED-60-H-30-A-R30-P		ESD-30-A	ESG-60-H-R30-P	1:500
	Ezi-SPEED-60-H-30-C-R30-P		ESD-30-C		
	Ezi-SPEED-60-H-30-A-R30-H		ESD-30-A	ESG-60-H-R30-H	1:1000
	Ezi-SPEED-60-H-30-C-R30-H		ESD-30-C		
	Ezi-SPEED-60-H-30-A-R50-P		ESD-30-A	ESG-60-H-R50-P	1:10000
	Ezi-SPEED-60-H-30-C-R50-P		ESD-30-C		
	Ezi-SPEED-60-H-30-A-R50-H		ESD-30-A	ESG-60-H-R50-H	1:100000
	Ezi-SPEED-60-H-30-C-R50-H		ESD-30-C		
	Ezi-SPEED-60-H-30-A-R100-P		ESD-30-A	ESG-60-H-R100-P	1:1000000
	Ezi-SPEED-60-H-30-C-R100-P		ESD-30-C		
	Ezi-SPEED-60-H-30-A-R100-H		ESD-30-A	ESG-60-H-R100-H	1:10000000
	Ezi-SPEED-60-H-30-C-R100-H		ESD-30-C		
	Ezi-SPEED-60-H-30-C-R200-P		ESD-30-C	ESG-60-H-R200-P	1:100000000
	Ezi-SPEED-60-H-30-C-R200-H		ESD-30-C		
Ezi-SPEED-60-H-30-C-R200-H	ESD-30-C	ESG-60-H-R200-H	1:1000000000		
Ezi-SPEED-60-H-30-C-R200-H	ESD-30-C				

● Combination with Gearbox

Output Power	Unit Part Number	Motor Model Number	Drive Model Number	Gearbox Model Number	Gear Ratio		
60W	Ezi-SPEED-80-H-60-A-R5-P	ESM-80-H-60	ESD-60-A	ESG-80-H-R5-P	1:5		
	Ezi-SPEED-80-H-60-C-R5-P		ESD-60-C				
	Ezi-SPEED-80-H-60-A-R5-H		ESD-60-A	ESG-80-H-R5-H			
	Ezi-SPEED-80-H-60-C-R5-H		ESD-60-C				
	Ezi-SPEED-80-H-60-A-R10-P		ESD-60-A	ESG-80-H-R10-P	1:10		
	Ezi-SPEED-80-H-60-C-R10-P		ESD-60-C				
	Ezi-SPEED-80-H-60-A-R10-H		ESD-60-A	ESG-80-H-R10-H			
	Ezi-SPEED-80-H-60-C-R10-H		ESD-60-C				
	Ezi-SPEED-80-H-60-A-R15-P		ESD-60-A	ESG-80-H-R15-P	1:15		
	Ezi-SPEED-80-H-60-C-R15-P		ESD-60-C				
	Ezi-SPEED-80-H-60-A-R15-H		ESD-60-A	ESG-80-H-R15-H			
	Ezi-SPEED-80-H-60-C-R15-H		ESD-60-C				
	Ezi-SPEED-80-H-60-A-R20-P		ESD-60-A	ESG-80-H-R20-P	1:20		
	Ezi-SPEED-80-H-60-C-R20-P		ESD-60-C				
	Ezi-SPEED-80-H-60-A-R20-H		ESD-60-A	ESG-80-H-R20-H			
	Ezi-SPEED-80-H-60-C-R20-H		ESD-60-C				
	Ezi-SPEED-80-H-60-A-R30-P		ESD-60-A	ESG-80-H-R30-P	1:30		
	Ezi-SPEED-80-H-60-C-R30-P		ESD-60-C				
	Ezi-SPEED-80-H-60-A-R30-H		ESD-60-A	ESG-80-H-R30-H			
	Ezi-SPEED-80-H-60-C-R30-H		ESD-60-C				
	Ezi-SPEED-80-H-60-A-R50-P		ESD-60-A	ESG-80-H-R50-P	1:50		
	Ezi-SPEED-80-H-60-C-R50-P		ESD-60-C				
	Ezi-SPEED-80-H-60-A-R50-H		ESD-60-A	ESG-80-H-R50-H			
	Ezi-SPEED-80-H-60-C-R50-H		ESD-60-C				
	Ezi-SPEED-80-H-60-A-R100-P		ESD-60-A	ESG-80-H-R100-P	1:100		
	Ezi-SPEED-80-H-60-C-R100-P		ESD-60-C				
	Ezi-SPEED-80-H-60-A-R100-H		ESD-60-A	ESG-80-H-R100-H			
	Ezi-SPEED-80-H-60-C-R100-H		ESD-60-C				
	Ezi-SPEED-80-H-60-A-R200-P		ESD-60-A	ESG-80-H-R200-P	1:200		
	Ezi-SPEED-80-H-60-C-R200-P		ESD-60-C				
	Ezi-SPEED-80-H-60-A-R200-H		ESD-60-A	ESG-80-H-R200-H			
	Ezi-SPEED-80-H-60-C-R200-H		ESD-60-C				
	120W		Ezi-SPEED-90-H-120-A-R5-P	ESM-90-H-120	ESD-120-A	ESG-90-H-R5-P	1:5
			Ezi-SPEED-90-H-120-C-R5-P		ESD-120-C		
			Ezi-SPEED-90-H-120-A-R5-H		ESD-120-A	ESG-90-H-R5-H	
			Ezi-SPEED-90-H-120-C-R5-H		ESD-120-C		
			Ezi-SPEED-90-H-120-A-R10-P		ESD-120-A	ESG-90-H-R10-P	1:10
			Ezi-SPEED-90-H-120-C-R10-P		ESD-120-C		
			Ezi-SPEED-90-H-120-A-R10-H		ESD-120-A	ESG-90-H-R10-H	
			Ezi-SPEED-90-H-120-C-R10-H		ESD-120-C		
			Ezi-SPEED-90-H-120-A-R15-P		ESD-120-A	ESG-90-H-R15-P	1:15
			Ezi-SPEED-90-H-120-C-R15-P		ESD-120-C		
Ezi-SPEED-90-H-120-A-R15-H		ESD-120-A	ESG-90-H-R15-H				
Ezi-SPEED-90-H-120-C-R15-H		ESD-120-C					
Ezi-SPEED-90-H-120-A-R20-P		ESD-120-A	ESG-90-H-R20-P		1:20		
Ezi-SPEED-90-H-120-C-R20-P		ESD-120-C					
Ezi-SPEED-90-H-120-A-R20-H		ESD-120-A	ESG-90-H-R20-H				
Ezi-SPEED-90-H-120-C-R20-H		ESD-120-C					
Ezi-SPEED-90-H-120-A-R30-P		ESD-120-A	ESG-90-H-R30-P		1:30		
Ezi-SPEED-90-H-120-C-R30-P		ESD-120-C					
Ezi-SPEED-90-H-120-A-R30-H		ESD-120-A	ESG-90-H-R30-H				
Ezi-SPEED-90-H-120-C-R30-H		ESD-120-C					
Ezi-SPEED-90-H-120-A-R50-P		ESD-120-A	ESG-90-H-R50-P		1:50		
Ezi-SPEED-90-H-120-C-R50-P		ESD-120-C					
Ezi-SPEED-90-H-120-A-R50-H		ESD-120-A	ESG-90-H-R50-H				
Ezi-SPEED-90-H-120-C-R50-H		ESD-120-C					
Ezi-SPEED-90-H-120-A-R100-P		ESD-120-A	ESG-90-H-R100-P		1:100		
Ezi-SPEED-90-H-120-C-R100-P		ESD-120-C					
Ezi-SPEED-90-H-120-A-R100-H		ESD-120-A	ESG-90-H-R100-H				
Ezi-SPEED-90-H-120-C-R100-H		ESD-120-C					
Ezi-SPEED-90-H-120-A-R200-P		ESD-120-A	ESG-90-H-R200-P		1:200		
Ezi-SPEED-90-H-120-C-R200-P		ESD-120-C					
Ezi-SPEED-90-H-120-A-R200-H		ESD-120-A	ESG-90-H-R200-H				
Ezi-SPEED-90-H-120-C-R200-H		ESD-120-C					

Output Power	Unit Part Number	Motor Model Number	Drive Model Number	Gearbox Model Number	Gear Ratio			
200W	Ezi-SPEED-104-H-200-C-R5-P	ESM-104-H-200	ESD-200-C	ESG-104-H-R5-P	1:5			
	Ezi-SPEED-104-H-200-C-R10-P			ESG-104-H-R10-P	1:10			
	Ezi-SPEED-104-H-200-C-R15-P			ESG-104-H-R15-P	1:15			
	Ezi-SPEED-104-H-200-C-R20-P			ESG-104-H-R20-P	1:20			
	Ezi-SPEED-104-H-200-C-R30-P			ESG-104-H-R30-P	1:30			
	Ezi-SPEED-104-H-200-C-R50-P			ESG-104-H-R50-P	1:50			
	Ezi-SPEED-104-H-200-C-R100-P			ESG-104-H-R100-P	1:100			
	Ezi-SPEED-104-H-200-C-R200-P			ESG-104-H-R200-P	1:200			
	400W			Ezi-SPEED-104-H-400-C-R5-P	ESM-104-H-400	ESD-400-C	ESG-104-H-R5-P	1:5
				Ezi-SPEED-104-H-400-C-R10-P			ESG-104-H-R10-P	1:10
				Ezi-SPEED-104-H-400-C-R15-P			ESG-104-H-R15-P	1:15
				Ezi-SPEED-104-H-400-C-R20-P			ESG-104-H-R20-P	1:20
Ezi-SPEED-104-H-400-C-R30-P		ESG-104-H-R30-P	1:30					
Ezi-SPEED-104-H-400-C-R50-P		ESG-104-H-R50-P	1:50					
Ezi-SPEED-104-H-400-C-R100-P		ESG-104-H-R100-P	1:100					
Ezi-SPEED-104-H-400-C-R200-P		ESG-104-H-R200-P	1:200					

● Specifications of Drive

1. Input Voltage 110V Specifications

Unit Part Number		ESD-30-A	ESD-60-A	ESD-120-A
Rated Output Power		30W	60W	120W
Power Supply Input	Rated Voltage	Single-Phase 100~120V		
	Frequency	50/60Hz		
	Permissible Frequency Range	±5%		
	Rated Input Current	0,95A	1,56A	2,69A
	Maximum Input Current	2,85A	4,68A	8,07A
Rated Output Current		0,21A	0,36A	0,85A
Rated Torque		0,096N·m	0,192N·m	0,382N·m
Maximum instantaneous Torque		0,288N·m	0,576N·m	1,146N·m
Rated Speed		3,000 [rpm]		
Speed Control Range		50~4,000 [rpm]		
Speed Regulation		0,2% or less / Conditions: 0~Rated Torque, Rated Speed, Rated Voltage, normal Temperature		
Protection Functions		Under voltage Error, Over voltage Error, Over heat Error, Over current Error, Speed feedback Error, Sensor Error, Over speed Error, Over load Error, Operation at power-on Error, External Error		
Environment	Temperature	· In Use: 0~40°C · In Storage: -20~70°C		
	Humidity	· In Use: 35~85% RH (Non-Condensing) · In Storage: 10~90% RH (Non-Condensing)		
	Vibration resistant	0,5g		
I/O Signal	Input Signal Function	5 user inputs (Photocoupler)		
	Output Signal Function	3 user outputs (Photocoupler)		

● Specifications of Drive

2. Input Voltage 220V Specifications

Unit Part Number		ESD-30-C	ESD-60-C	ESD-120-C	ESD-200-C	ESD-400-C
Rated Output Power		30W	60W	120W	200W	400W
Power Supply Input	Rated Voltage	Single-Phase 200~240V / Three-Phase 200~240V				
	Frequency	50/60Hz				
	Permissible Frequency Range	±5%				
	Rated Input Current	Single-Phase : 0,55A Three-Phase : 0,32A	Single-Phase : 0,92A Three-Phase : 0,53A	Single-Phase : 1,61A Three-Phase : 0,93A	Single-Phase : 2,34A Three-Phase : 1,35A	Single-Phase : 3,88A Three-Phase : 2,24A
	Maximum Input Current	Single-Phase : 1,65A Three-Phase : 0,95A	Single-Phase : 2,76A Three-Phase : 1,59A	Single-Phase : 4,83A Three-Phase : 2,79A	Single-Phase : 7,02A Three-Phase : 4,05A	Single-Phase : 11,64A Three-Phase : 6,72A
Rated Output Current		0,21A	0,36A	0,85A	1,65A	2,37A
Rated Torque		0,096N · m	0,192N · m	0,382N · m	0,637N · m	1,272N · m
Maximum instantaneous Torque		0,288N · m	0,576N · m	1,146N · m	1,911N · m	3,816N · m
Rated Speed		3,000 [rpm]				
Speed Control Range		50~4,000 [rpm]				
Speed Regulation		0,2% or less / Conditions: 0~Rated Torque, Rated Speed, Rated Voltage, normal Temperature				
Protection Functions		Under voltage Error, Over voltage Error, Over heat Error, Over current Error, Speed feedback Error, Sensor Error, Over speed Error, Over load Error, Operation at power-on Error, External Error				
Environment	Temperature	· In Use: 0~40°C · In Storage: -20~70°C				
	Humidity	· In Use: 35~85% RH (Non-Condensing) · In Storage: 10~90% RH (Non-Condensing)				
	Vibration resistant	0,5g				
I/O Signal	Input Signal Function	5 user inputs (Photocoupler)				
	Output Signal Function	3 user outputs (Photocoupler)				

● Dimensions of Drive [mm]

1. 30, 60, 120W Drive

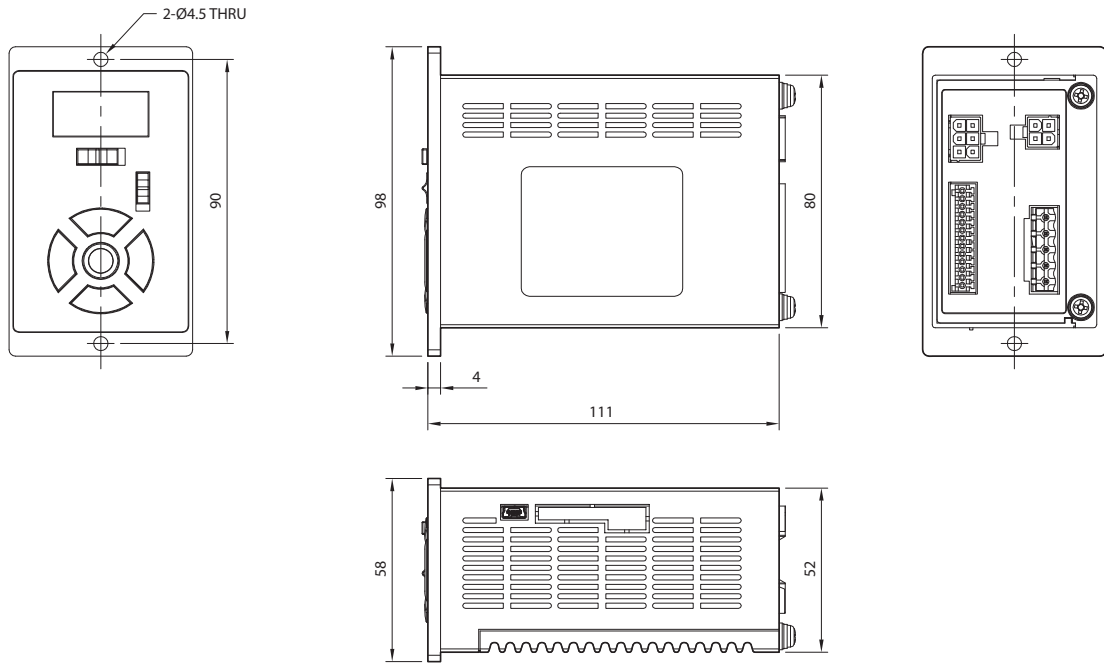

2. 200, 400W Drive

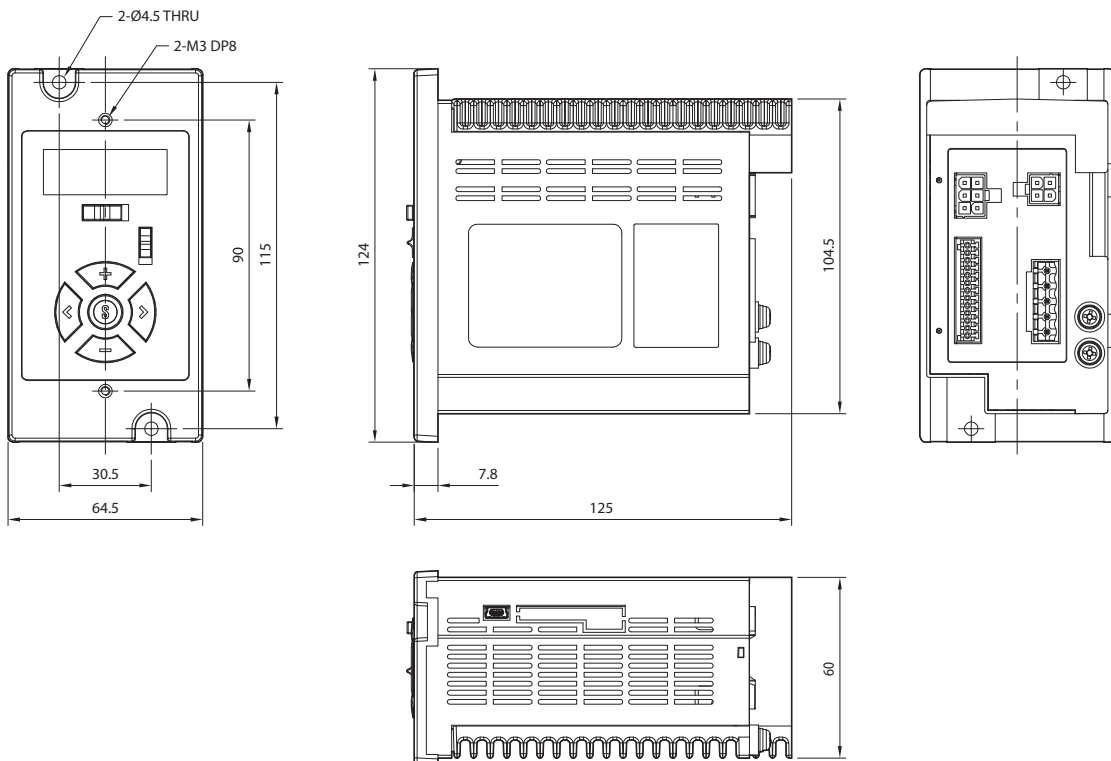

● Specifications of Motor

MODEL	UNIT	ESM-60-S-30	ESM-80-S-60	ESM-90-S-120	ESM-104-S-200	ESM-104-S-400
	RATED OUTPUT POWER (CONTINUOUS)	W	30	60	120	200
RATED TORQUE	N·m	0,096	0,192	0,382	0,637	1,272
RATED INPUT CURRENT	A	0,21	0,36	0,85	1,65	2,37
RATED SPEED	rpm	3,000				
PERMISSIBLE LOAD INERTIA MOMENT	$10^{-4}\text{kg}\cdot\text{m}^2$	0,5	1,8	5,8	5,8	8,75
INERTIA MOMENT	$10^{-4}\text{kg}\cdot\text{m}^2$	0,086	0,234	0,61	0,61	0,66
WEIGHT	kg	0,5	0,8	1,3	2,4	2,4
LENGTH(L)	mm	62	74	94	156	156
PERMISSIBLE OVERHUNG LOAD	10mm from shaft end [N]	70	120	160	160	160
	20mm from shaft end [N]	100	140	170	170	170

Torque Characteristics of Motor

Ezi-SPEED-30W

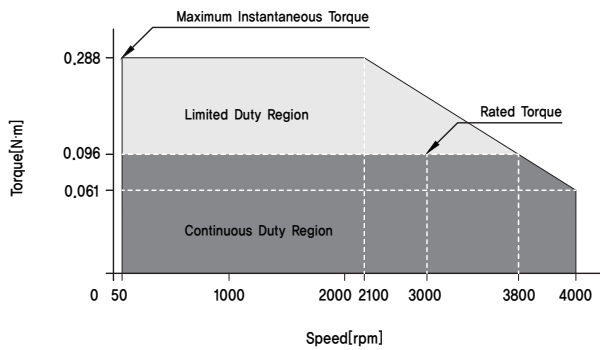

Ezi-SPEED-60W

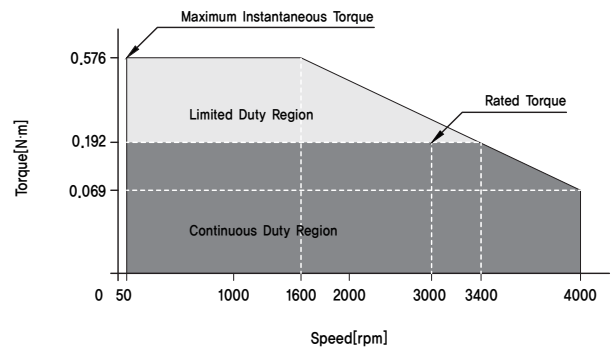

Ezi-SPEED-120W

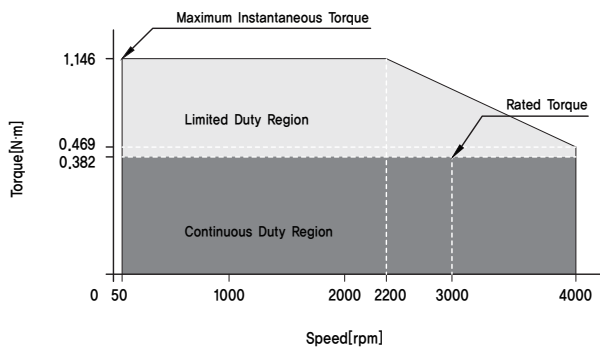

Ezi-SPEED-200W

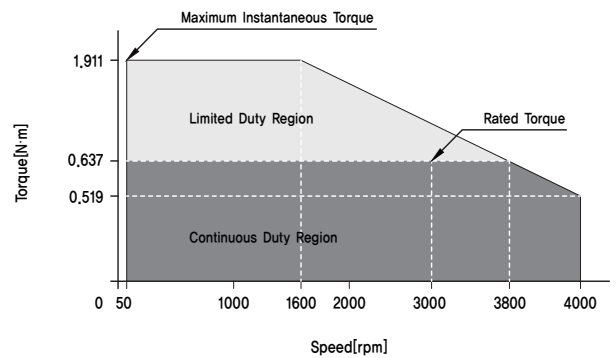

Ezi-SPEED-400W

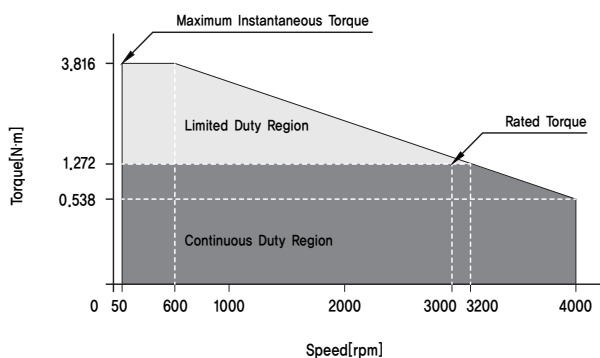

● Dimensions of Motor [mm]

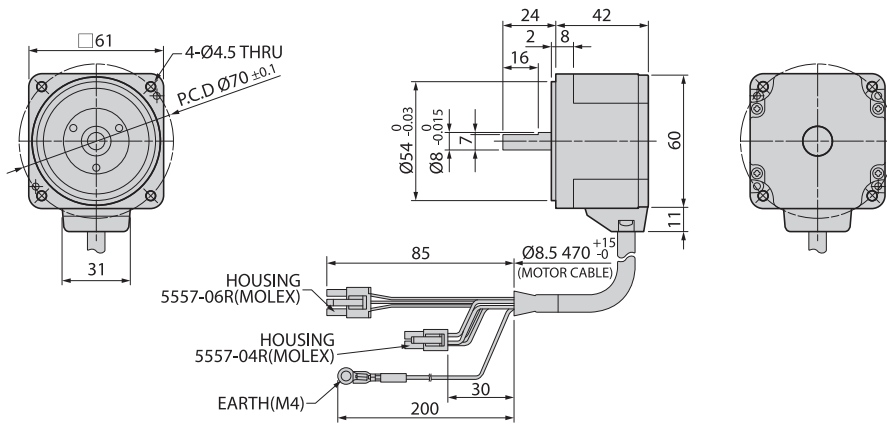

30_W
ESM-60-S-30

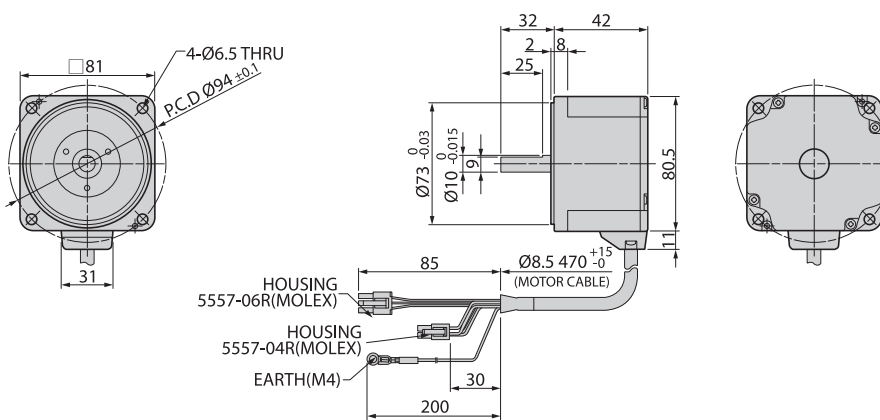

60_W
ESM-80-S-60

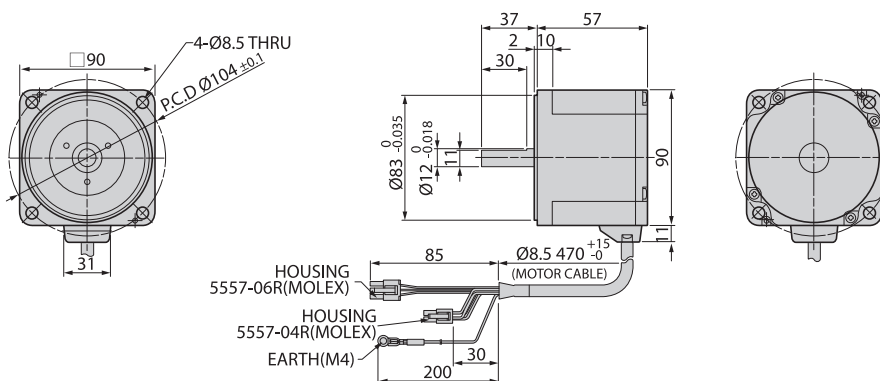

120_W
ESM-90-S-120

● Dimensions of Motor [mm]

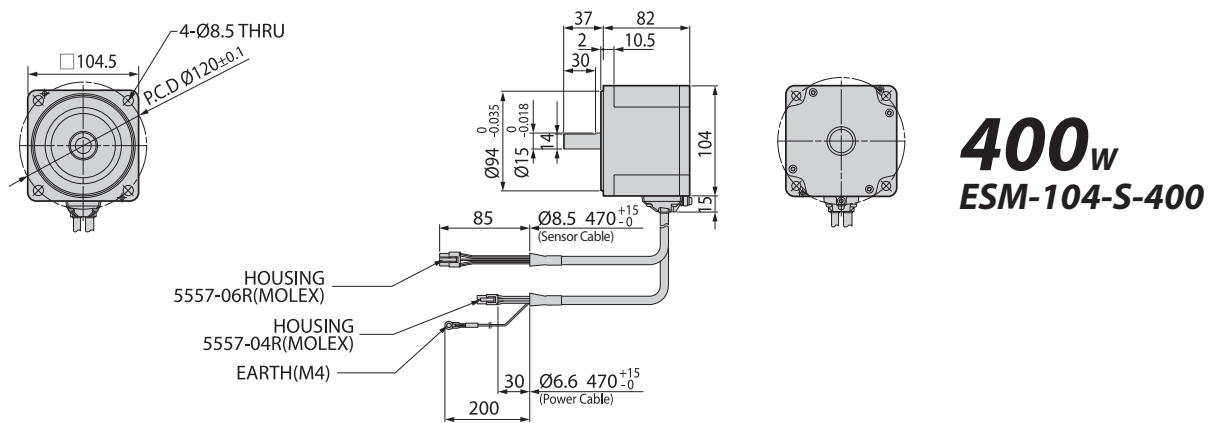
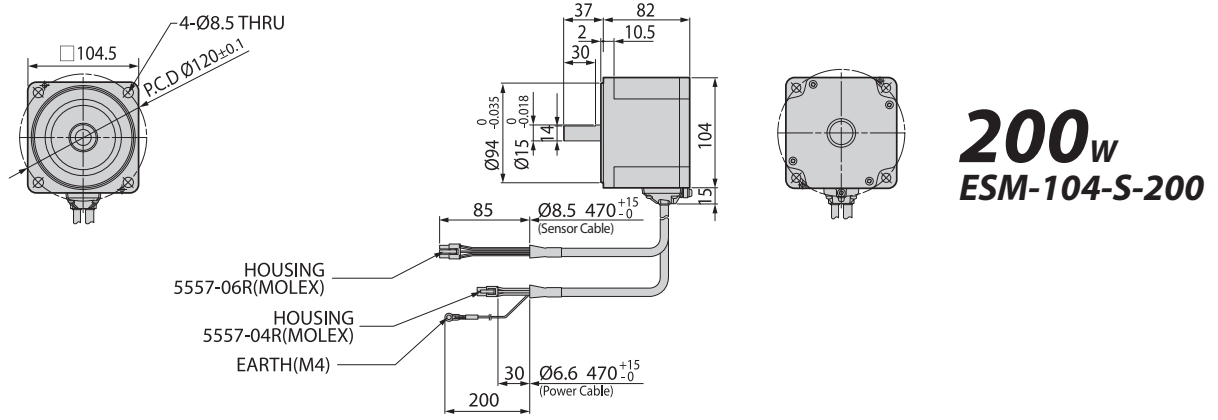

● Specifications of Motor with Gearbox

30_w

Unit Part Number	Gear Ratio	Permitted Torque [N·m]		Permitted Speed Range [rpm]	Unit Weight [kg]	Permitted Overhung Load [N]		Permitted Thrust Load [N]
		50~3,000 [rpm]	4,000 [rpm]			10mm from shaft end	20mm from shaft end	
Ezi-SPEED-60-H-30-A-R5-P	5	0.45	0.34	10~800	0.9	100	150	40
Ezi-SPEED-60-H-30-C-R5-P								
Ezi-SPEED-60-H-30-A-R10-P	10	0.9	0.68	5~400				
Ezi-SPEED-60-H-30-C-R10-P								
Ezi-SPEED-60-H-30-A-R15-P	15	1.35	1	3.3~266.7				
Ezi-SPEED-60-H-30-C-R15-P								
Ezi-SPEED-60-H-30-A-R20-P	20	1.8	1.4	2.5~200				
Ezi-SPEED-60-H-30-C-R20-P								
Ezi-SPEED-60-H-30-A-R30-P	30	2.6	1.9	1.7~133.3				
Ezi-SPEED-60-H-30-C-R30-P								
Ezi-SPEED-60-H-30-A-R50-P	50	4.3	3.2	1~80				
Ezi-SPEED-60-H-30-C-R50-P								
Ezi-SPEED-60-H-30-A-R100-P	100	6	5.4	0.5~40				
Ezi-SPEED-60-H-30-C-R100-P								
Ezi-SPEED-60-H-30-A-R200-P	200	6	5.4	0.25~20				
Ezi-SPEED-60-H-30-C-R200-P								

60_w

Unit Part Number	Gear Ratio	Permitted Torque [N·m]		Permitted Speed Range [rpm]	Unit Weight [kg]	Permitted Overhung Load [N]		Permitted Thrust Load [N]
		50~3,000 [rpm]	4,000 [rpm]			10mm from shaft end	20mm from shaft end	
Ezi-SPEED-80-H-60-A-R5-P	5	0.9	0.68	10~800	1.6	200	250	100
Ezi-SPEED-80-H-60-C-R5-P								
Ezi-SPEED-80-H-60-A-R10-P	10	1.8	1.4	5~400				
Ezi-SPEED-80-H-60-C-R10-P								
Ezi-SPEED-80-H-60-A-R15-P	15	2.7	2	3.3~266.7				
Ezi-SPEED-80-H-60-C-R15-P								
Ezi-SPEED-80-H-60-A-R20-P	20	3.6	2.7	2.5~200				
Ezi-SPEED-80-H-60-C-R20-P								
Ezi-SPEED-80-H-60-A-R30-P	30	5.2	3.9	1.7~133.3				
Ezi-SPEED-80-H-60-C-R30-P								
Ezi-SPEED-80-H-60-A-R50-P	50	8.6	6.5	1~80				
Ezi-SPEED-80-H-60-C-R50-P								
Ezi-SPEED-80-H-60-A-R100-P	100	16	12.9	0.5~40				
Ezi-SPEED-80-H-60-C-R100-P								
Ezi-SPEED-80-H-60-A-R200-P	200	16	14	0.25~20				
Ezi-SPEED-80-H-60-C-R200-P								

● Specifications of Motor with Gearbox

120_w

Unit Part Number	Gear Ratio	Permitted Torque [N·m]		Permitted Speed Range [rpm]	Unit Weight [kg]	Permitted Overhung Load [N]		Permitted Thrust Load [N]
		50~3,000 [rpm]	4,000 [rpm]			10mm from shaft end	20mm from shaft end	
Ezi-SPEED-90-H-120-A-R5-P	5	1.8	1.4	10~800	2.7	300	400	150
Ezi-SPEED-90-H-120-C-R5-P								
Ezi-SPEED-90-H-120-A-R10-P	10	3.6	2.7	5~400				
Ezi-SPEED-90-H-120-C-R10-P								
Ezi-SPEED-90-H-120-A-R15-P	15	5.4	4.1	3.3~266.7				
Ezi-SPEED-90-H-120-C-R15-P								
Ezi-SPEED-90-H-120-A-R20-P	20	7.2	5.4	2.5~200				
Ezi-SPEED-90-H-120-C-R20-P								
Ezi-SPEED-90-H-120-A-R30-P	30	10.3	7.7	1.7~133.3				
Ezi-SPEED-90-H-120-C-R30-P								
Ezi-SPEED-90-H-120-A-R50-P	50	17.2	12.9	1~80				
Ezi-SPEED-90-H-120-C-R50-P								
Ezi-SPEED-90-H-120-A-R100-P	100	30	25.8	0.5~40				
Ezi-SPEED-90-H-120-C-R100-P								
Ezi-SPEED-90-H-120-A-R200-P	200	30	27	0.25~20				
Ezi-SPEED-90-H-120-C-R200-P								

200_w

Unit Part Number	Gear Ratio	Permitted Torque [N·m]		Permitted Speed Range [rpm]	Unit Weight [kg]	Permitted Overhung Load [N]		Permitted Thrust Load [N]
		50~3,000 [rpm]	4,000 [rpm]			10mm from shaft end	20mm from shaft end	
Ezi-SPEED-104-H-200-C-R5-P	5	2.9	2	10~800	4.2	300	400	150
Ezi-SPEED-104-H-200-C-R10-P	10	5.9	4.1	5~400				
Ezi-SPEED-104-H-200-C-R15-P	15	8.8	6.1	3.3~266.7				
Ezi-SPEED-104-H-200-C-R20-P	20	11.7	8.1	2.5~200				
Ezi-SPEED-104-H-200-C-R30-P	30	16.8	11.6	1.7~133.3				
Ezi-SPEED-104-H-200-C-R50-P	50	28	19.4	1~80				
Ezi-SPEED-104-H-200-C-R100-P	100	52.7	36.5	0.5~40				
Ezi-SPEED-104-H-200-C-R200-P	200	70	63	0.25~20				

● Specifications of Motor with Gearbox

400_w

Unit Part Number	Gear Ratio	Permitted Torque [N·m]		Permitted Speed Range [rpm]	Unit Weight [kg]	Permitted Overhung Load [N]		Permitted Thrust Load [N]
		50~3,000 [rpm]	4,000 [rpm]			10mm from shaft end	20mm from shaft end	
Ezi-SPEED-104-H-400-C-R5-P	5	5,9	4,3	10~800	4,2	300	400	150
Ezi-SPEED-104-H-400-C-R10-P	10	11,7	8,6	5~400		400	500	
Ezi-SPEED-104-H-400-C-R15-P	15	17,6	12,8	3,3~266,7				
Ezi-SPEED-104-H-400-C-R20-P	20	23,4	17,1	2,5~200				
Ezi-SPEED-104-H-400-C-R30-P	30	33,5	24,5	1,7~133,3		500	650	
Ezi-SPEED-104-H-400-C-R50-P	50	55,9	40,9	1~80				
Ezi-SPEED-104-H-400-C-R100-P	100	70	63	0,5~40				
Ezi-SPEED-104-H-400-C-R200-P	200	70	63	0,25~20				

● Specifications of Motor with Hollow Shaft Gearbox

30_w

Unit Part Number	Gear Ratio	Permitted Torque [N·m]		Permitted Speed Range [rpm]	Unit Weight [kg]	Permitted Overhung Load [N]		Permitted Thrust Load [N]
		50~3,000 [rpm]	4,000 [rpm]			10mm from shaft end	20mm from shaft end	
Ezi-SPEED-60-H-30-A-R5-H	5	0.4	0.3	10~800	1.2	450	370	200
Ezi-SPEED-60-H-30-C-R5-H								
Ezi-SPEED-60-H-30-A-R10-H	10	0.85	0.64	5~400				
Ezi-SPEED-60-H-30-C-R10-H								
Ezi-SPEED-60-H-30-A-R15-H	15	1.3	0.96	3.3~266.7				
Ezi-SPEED-60-H-30-C-R15-H								
Ezi-SPEED-60-H-30-A-R20-H	20	1.7	1.3	2.5~200				
Ezi-SPEED-60-H-30-C-R20-H								
Ezi-SPEED-60-H-30-A-R30-H	30	2.6	1.9	1.7~133.3				
Ezi-SPEED-60-H-30-C-R30-H								
Ezi-SPEED-60-H-30-A-R50-H	50	4.3	3.2	1~80				
Ezi-SPEED-60-H-30-C-R50-H								
Ezi-SPEED-60-H-30-A-R100-H	100	8.5	6.4	0.5~40				
Ezi-SPEED-60-H-30-C-R100-H								
Ezi-SPEED-60-H-30-A-R200-H	200	17	12.8	0.25~20				
Ezi-SPEED-60-H-30-C-R200-H								

60_w

Unit Part Number	Gear Ratio	Permitted Torque [N·m]		Permitted Speed Range [rpm]	Unit Weight [kg]	Permitted Overhung Load [N]		Permitted Thrust Load [N]
		50~3,000 [rpm]	4,000 [rpm]			10mm from shaft end	20mm from shaft end	
Ezi-SPEED-80-H-60-A-R5-H	5	0.85	0.64	10~800	2.2	800	660	400
Ezi-SPEED-80-H-60-C-R5-H								
Ezi-SPEED-80-H-60-A-R10-H	10	1.7	1.3	5~400				
Ezi-SPEED-80-H-60-C-R10-H								
Ezi-SPEED-80-H-60-A-R15-H	15	2.6	1.9	3.3~266.7				
Ezi-SPEED-80-H-60-C-R15-H								
Ezi-SPEED-80-H-60-A-R20-H	20	3.4	2.6	2.5~200				
Ezi-SPEED-80-H-60-C-R20-H								
Ezi-SPEED-80-H-60-A-R30-H	30	5.1	3.8	1.7~133.3				
Ezi-SPEED-80-H-60-C-R30-H								
Ezi-SPEED-80-H-60-A-R50-H	50	8.5	6.4	1~80				
Ezi-SPEED-80-H-60-C-R50-H								
Ezi-SPEED-80-H-60-A-R100-H	100	17	12.8	0.5~40				
Ezi-SPEED-80-H-60-C-R100-H								
Ezi-SPEED-80-H-60-A-R200-H	200	34	25	0.25~20				
Ezi-SPEED-80-H-60-C-R200-H								

● Specifications of Motor with Hollow Shaft Gearbox

120_w

Unit Part Number	Gear Ratio	Permitted Torque [N·m]		Permitted Speed Range [rpm]	Unit Weight [kg]	Permitted Overhung Load [N]		Permitted Thrust Load [N]
		50~3,000 [rpm]	4,000 [rpm]			10mm from shaft end	20mm from shaft end	
Ezi-SPEED-90-H-120-A-R5-H	5	1.7	1.3	10~800	3.3	900	770	500
Ezi-SPEED-90-H-120-C-R5-H								
Ezi-SPEED-90-H-120-A-R10-H	10	3.4	2.6	5~400				
Ezi-SPEED-90-H-120-C-R10-H								
Ezi-SPEED-90-H-120-A-R15-H	15	5.1	3.8	3.3~266.7				
Ezi-SPEED-90-H-120-C-R15-H								
Ezi-SPEED-90-H-120-A-R20-H	20	6.8	5.1	2.5~200				
Ezi-SPEED-90-H-120-C-R20-H								
Ezi-SPEED-90-H-120-A-R30-H	30	10.2	7.7	1.7~133.3				
Ezi-SPEED-90-H-120-C-R30-H								
Ezi-SPEED-90-H-120-A-R50-H	50	17	12.8	1~80				
Ezi-SPEED-90-H-120-C-R50-H								
Ezi-SPEED-90-H-120-A-R100-H	100	34	25.5	0.5~40				
Ezi-SPEED-90-H-120-C-R100-H								
Ezi-SPEED-90-H-120-A-R200-H	200	68	51	0.25~20				
Ezi-SPEED-90-H-120-C-R200-H								

● Dimensions of Motor with Gearbox [mm]

30_w

Unit Part Number	Gearbox Part Number	□ Reduction Gear Ratio	Mounting Bolt	L Length [mm]
Ezi-SPEED-60-H-30-A-R□-P	ESG-60-H-R□-P	5, 10, 15, 20	M4×50	34
Ezi-SPEED-60-H-30-C-R□-P		30, 50, 100	M4×55	38
		200	M4×60	43

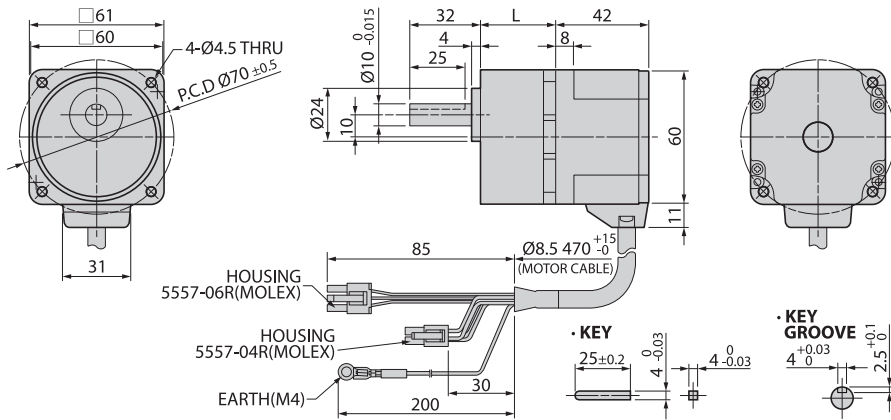

60_w

Unit Part Number	Gearbox Part Number	□ Reduction Gear Ratio	Mounting Bolt	L Length [mm]
Ezi-SPEED-80-H-60-A-R□-P	ESG-80-H-R□-P	5, 10, 15, 20	M4×65	41
Ezi-SPEED-80-H-60-C-R□-P		30, 50, 100	M4×70	46
		200	M4×75	51

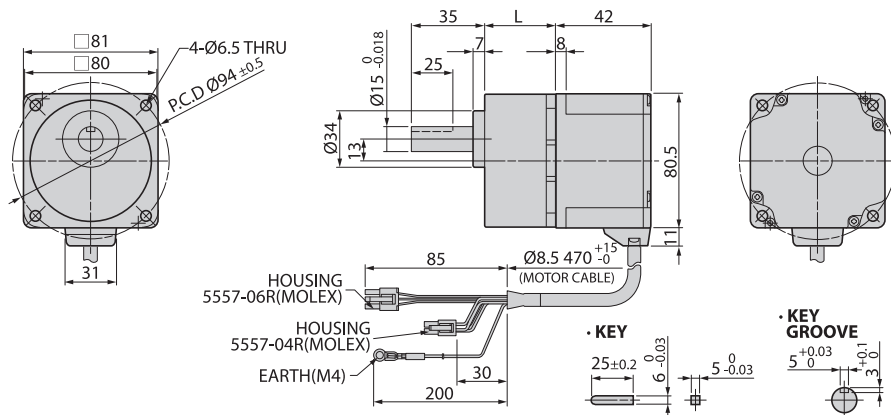

● Dimensions of Motor with Gearbox [mm]

120_w

Unit Part Number	Gearbox Part Number	□ Reduction Gear Ratio	Mounting Bolt	L Length [mm]
Ezi-SPEED-90-H-120-A-R□-P Ezi-SPEED-90-H-120-C-R□-P	ESG-90-H-R□-P	5, 10, 15, 20	M8×75	45
		30, 50, 100	M8×90	58
		200	M8×95	64

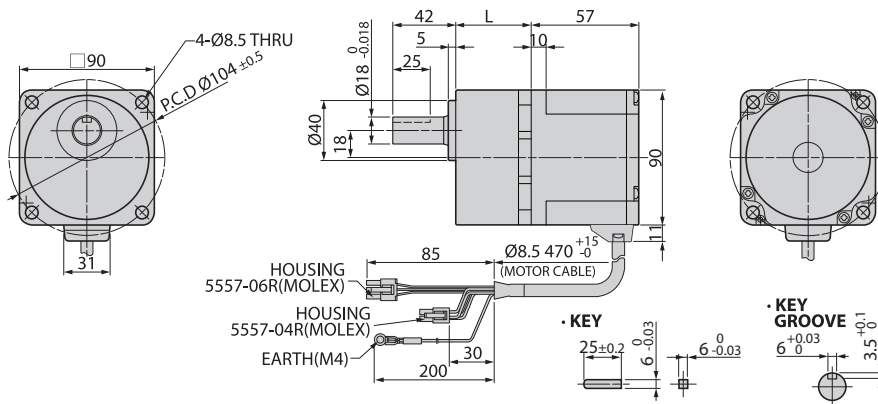

200_w

Unit Part Number	Gearbox Part Number	□ Reduction Gear Ratio	Mounting Bolt	L Length [mm]
Ezi-SPEED-104-H-200-C-R□-P	ESG-104-H-R□-P	5, 10, 15, 20	M8×95	60
		30, 50, 100	M8×110	72
		200	M8×120	86

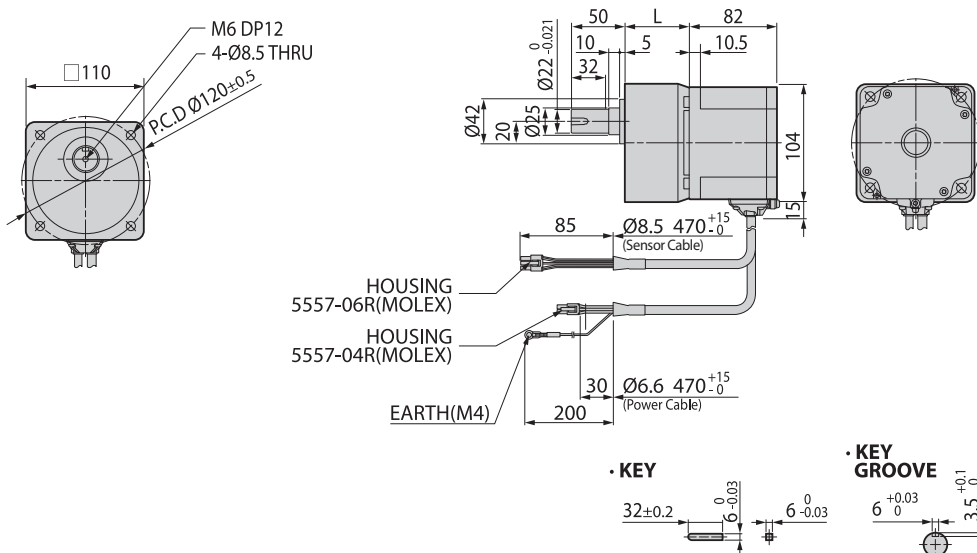

● Dimensions of Motor with Gearbox [mm]

400_w

Unit Part Number	Gearbox Part Number	□ Reduction Gear Ratio	Mounting Bolt	L Length [mm]
Ezi-SPEED-104-H-400-C-R□-P	ESG-104-H-R□-P	5, 10, 15, 20	M8×95	60
		30, 50, 100	M8×110	72
		200	M8×120	86

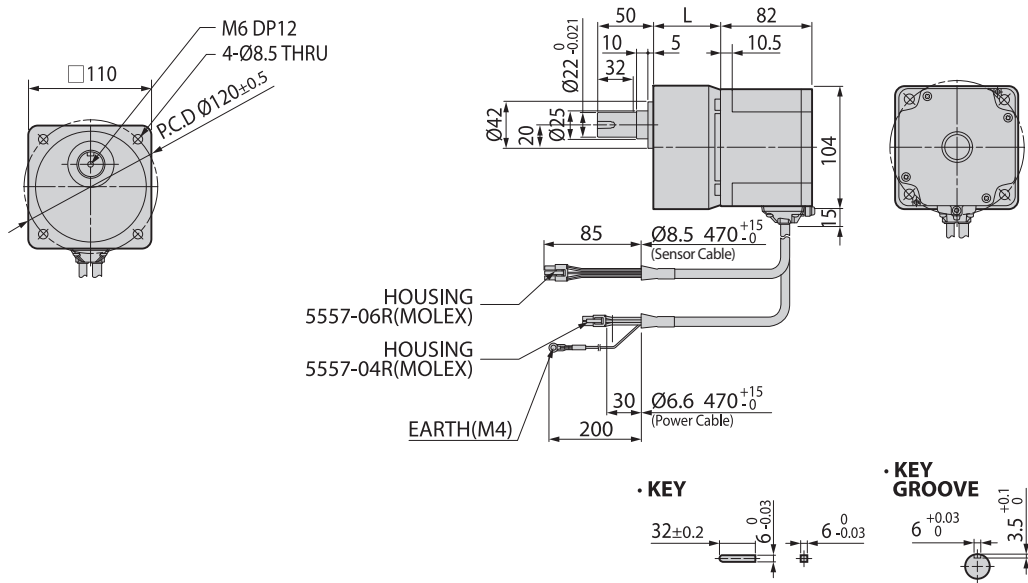

● Dimensions of Motor with Hollow shaft Gearbox [mm]

30_w

Unit Part Number	Gearbox Part Number	□ Reduction Gear Ratio	Mounting Bolt
Ezi-SPEED-60-H-30-A-R□-H Ezi-SPEED-60-H-30-C-R□-H	ESG-60-H-R□-H	5, 10, 15, 20, 30, 50, 100, 200	M5×65

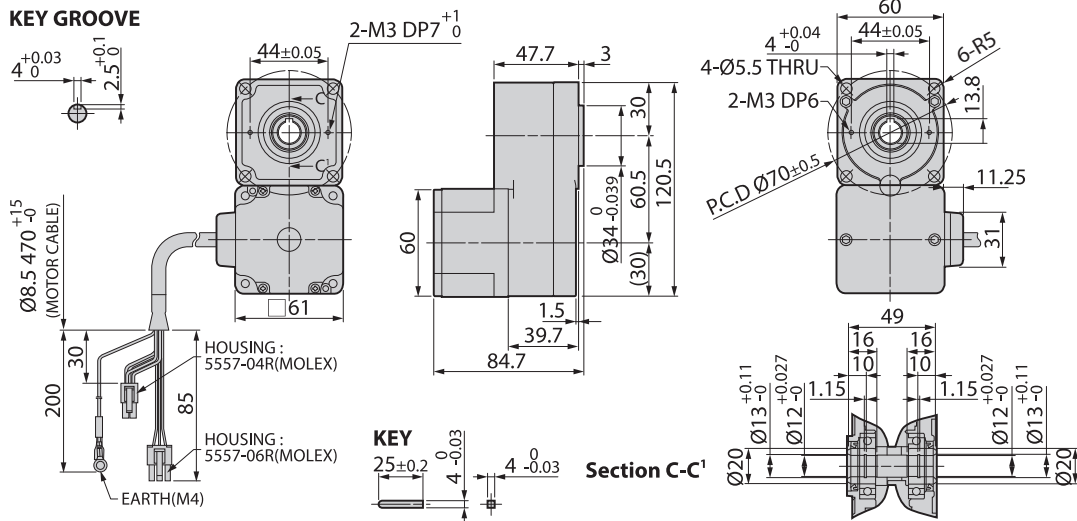

60_w

Unit Part Number	Gearbox Part Number	□ Reduction Gear Ratio	Mounting Bolt
Ezi-SPEED-80-H-60-A-R□-H Ezi-SPEED-80-H-60-C-R□-H	ESG-80-H-R□-H	5, 10, 15, 20, 30, 50, 100, 200	M6×70

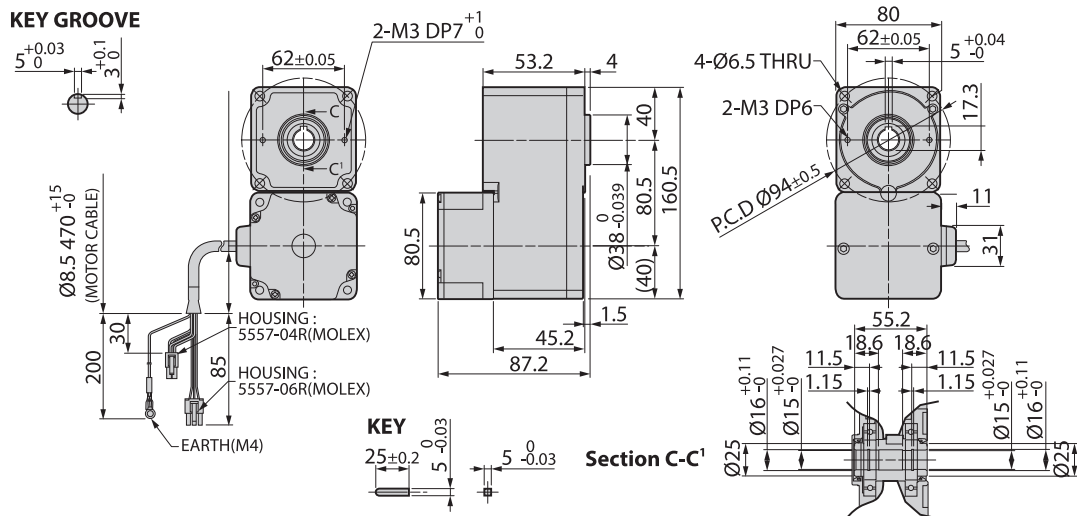

● Dimensions of Motor with Hollow shaft Gearbox [mm]

120_w

Unit Part Number	Gearbox Part Number	□ Reduction Gear Ratio	Mounting Bolt
Ezi-SPEED-90-H-120-A-R□-H Ezi-SPEED-90-H-120-C-R□-H	ESG-90-H-R□-H	5, 10, 15, 20, 30, 50, 100, 200	M8×90

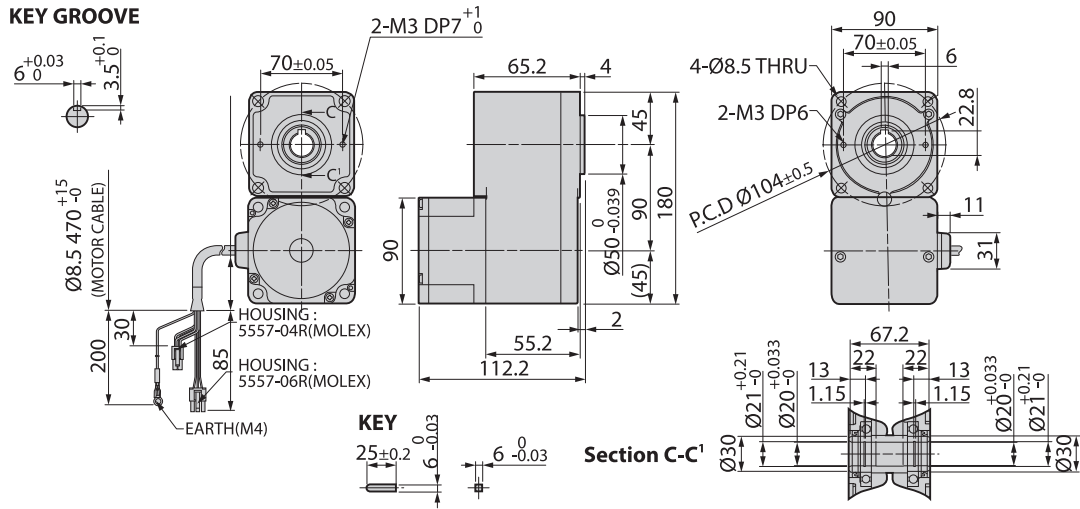

● Settings and Operation

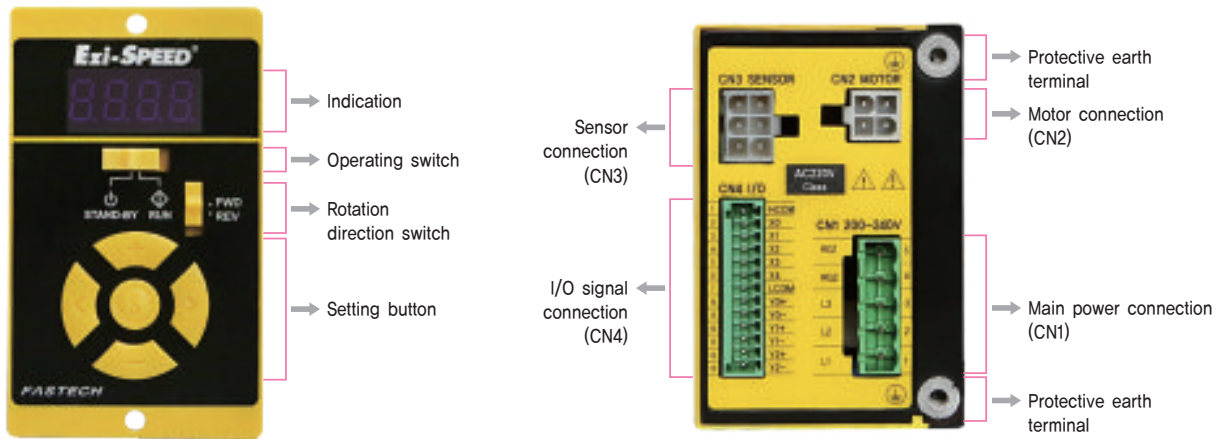

1. Setting

Indication	Conditions
Indication	Display the monitoring items, parameter, alarm, warning, etc
Operating Switch	The motor is started by setting it to the "RUN" position Setting it to the "STAND-BY" position stop the motor
Rotation Direction Switch	Change the rotation direction of the motor with rotation direction switch
Setting Button	Changes the speed and parameters The value is set when the "S" button is pressed after changes are made
Protective Earth Terminal	Ground either one of the protective earth terminals
Sensor Connection (CN3)	Connects to the signal Connection of the motor
Motor Connection (CN2)	Connects to the power Connection of the motor
I/O Signal Connection (CN4)	Connects with the I/O signals
Main Power Connection (CN1)	Connects to the main power supply and regenerative resistor

● Extended Functions

Ezi-SPEED can be perform various setting by operation button

Operating Mode	Conditions
Monitor Mode	Speed, Actual speed, Load factor, Alarm record and reset, Warning record and reset, Operating data number, I/O monitor
Data Mode	Data 8 points, Operating speed, Acceleration time, Deceleration time, Operating data reset
Parameter Mode	The acceleration/deceleration time, The overload alarm detection time, The speed upper limit and lower limit, Speed reduction ratio, Speed increasing ratio, Panel initial view, Alarm of "Run" condition at power on, External operation signal input, External input function, External output function, Speed attainment width, Parameter mode reset
NVM Saving Mode	Parameter save to NVM(Non-Volatile Memory)

2. Main Power Connector(CN1)

NO.	Function	I/O
1	L1	Input
2	L2	Input
3	L3	Input
4	RG2	Input
5	RG1	Input

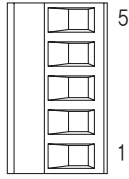

* Use RG1, RG2 terminals when connecting a regenerative resistor.
A regenerative resistor can be used when the deceleration time is short or large inertia is used.

* Please refer to the manual for details of regenerative resistor specification.

• Main Power Connection(CN1)

Single-Phase : 100~120V / 200~240V

Three-Phase : 200~240V

Regenerative resistor



• Applicable Lead Wire Size

AWG18~14 (0.75~2.0mm²)

3. Motor Connector(CN2)

NO.	Function	I/O
1	-	-
2	BLDC_U	Output
3	BLDC_W	Output
4	BLDC_V	Output

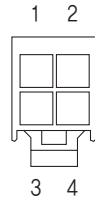

4. Sensor Connector(CN3)

NO.	Function	I/O
1	5VDC	Output
2	GND	-
3	GND	Output
4	HALL_U	Input
5	HALL_V	Input
6	HALL_W	Input

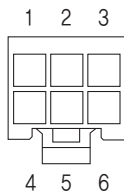

5. I/O Signal Connector(CN4)

NO.	Function	I/O
1	HCOM	Common
2	X0	Input
3	X1	Input
4	X2	Input
5	X3	Input
6	X4	Input
7	LCOM	Common
8	Y0+	Output
9	Y0-	Output
10	Y1+	Output
11	Y1-	Output
12	Y2+	Output
13	Y2-	Output

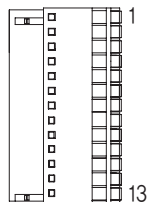

• Applicable Lead Wire Size

AWG26~20 (0.14~0.5mm²)

6. Operating with Drive

• Running the motor

Set the operation switch to the "RUN", the motor to start rotating.

• Adjust the speed

Pressing the  button, the speed increase by 1 [rpm]

Pressing the  button, the speed decrease by 1 [rpm]

• Determining the speed

· Set

Pressing the  button, the rotation speed is determined.
When the display is blinking, the rotation speed has not set.

· Confirmation

To prevent unwanted changes of the speed, press  for 5 seconds until "LOCK" displayed in the STAND-BY mode.

• Stopping the motor

Setting the operation switch to the "STAND-BY" side causes the motor to decelerate to a stop.

Setting the operation switch again to the "RUN" side causes the motor to start rotating at the set rotation speed.

• Changing the rotation direction

Change the rotation direction of the motor (gearbox) using the rotation direction switch. The rotation direction can be changed while operating. With the combination type, the rotation direction of the gearbox output shaft varies depending on the rear ratio of the gearbox.



7. Operation by I/O Signals

• Operation Method

- Using the built-in power supply in the driver, the motor is operated through external signals.
- Connect Pins the I/O signal connector as in the figure of the right.
- When operating using external signals, change the parameter setting in the “external operation signal input” to “on”. Refer to Manual.
- Using the external I/O signals, the motor can be operated 8-Speeds data.

Pin No.	Terminal Name	Input/Output	Signal Name	Description
1	HCOM	Common	-	Input signal common: Sink Logic +24V, Source Logic 0V(GND)
2	X0	Input	FWD	The motor rotates is FWD direction during signal “ON”
3	X1	Input	REV	The motor rotates is REV direction during signal “ON”
4	X2	Input	P0	Select the operating data
5	X3	Input	P1	Select the operating data
6	X4	Input	Rst	Reset the alarm
7	LCOM	Common	-	Input signal common
8	Y0+	Output	SPd	For every rotation of the motor, 30 pulses are output
9	Y0-	Output		
10	Y1+	Output	ALon	It turns off when an alarm is generated (Normally closed)
11	Y1-	Output		
12	Y2+	Output	ALovE	It turns on when the motor is operated (Normally opened)
13	Y2-	Output		

※ [] Function in [] is assigned at shipment

※ Can be assigned required functions to 5 input signals(X0~X4) and 3 output signals(Y0~Y2)

· Input signals: Can be used 5 functions out of Fwd(CW rotation), rEv(CCW rotation), P0(Operation data 1), P1(Operation data 2), P2(Operation data 2), A,rst(Alarm reset), E,Err(External alarm), H-Fr(Motor activation/deactivation)

· Output signals: Can be used 3 functions out of SPd(Speed output), AL_on(Alarm output), AL_ov(Overvoltage alarm output), OvLd(Overload alarm output), Mov(Motor operation output), vA(Speed attainment alarm), WnG(Warning alarm)

• Reading of 7-Segment

Can read the Arabic numerals and alphabets displayed on the 7-segment as follows.

· Arabic numerals

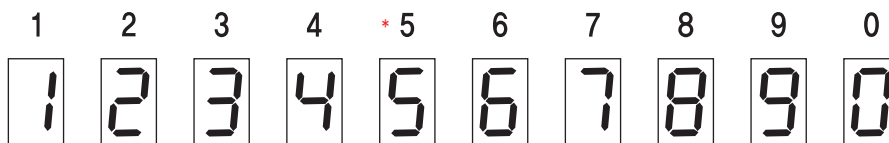

· Alphabets

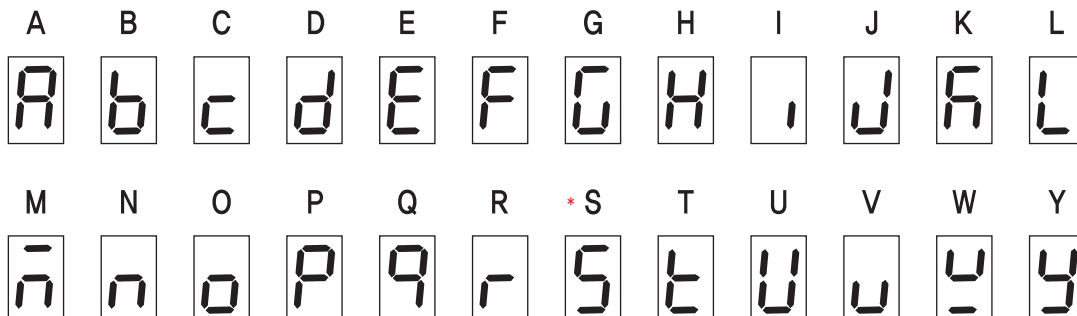

* Please note that the Arabic numerals “5” and the letter “S” shown above are displayed identically.

• Timing Chart

In case of parameter “external operation signal input” to “on” and the rotation direction switch is set to “FWD”.

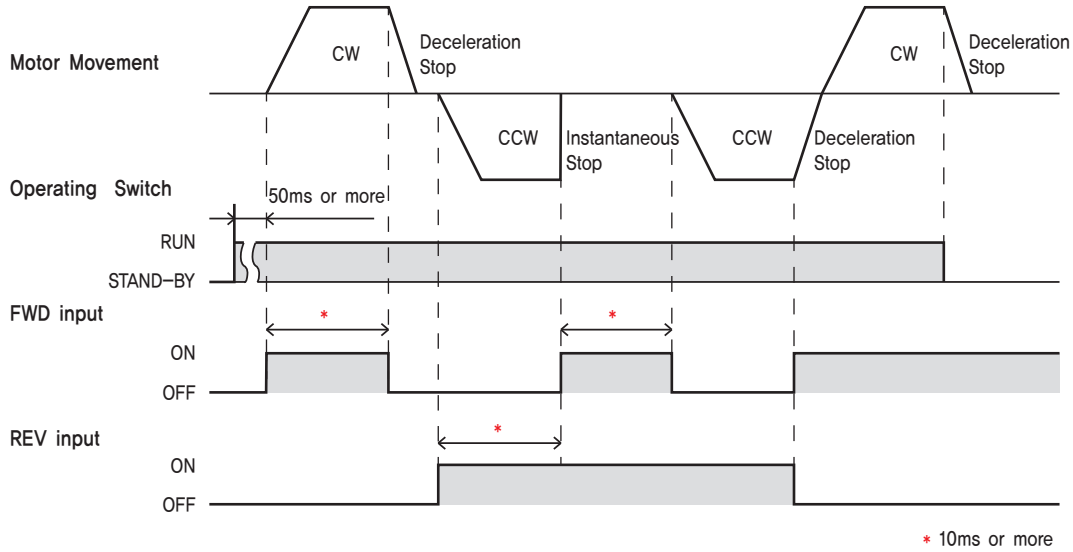

- The motor rotates when either FWD input or REV input is set to “ON”.
- The motor instantaneous stop when FWD input and REV input is set to “ON” at the same time.
- Stop movement can differ according to gear box and load inertia.

• Example of connection using Switches or Relays

This is an example of connection when operating Ezi-SPEED using contact switches such as switches or relays.

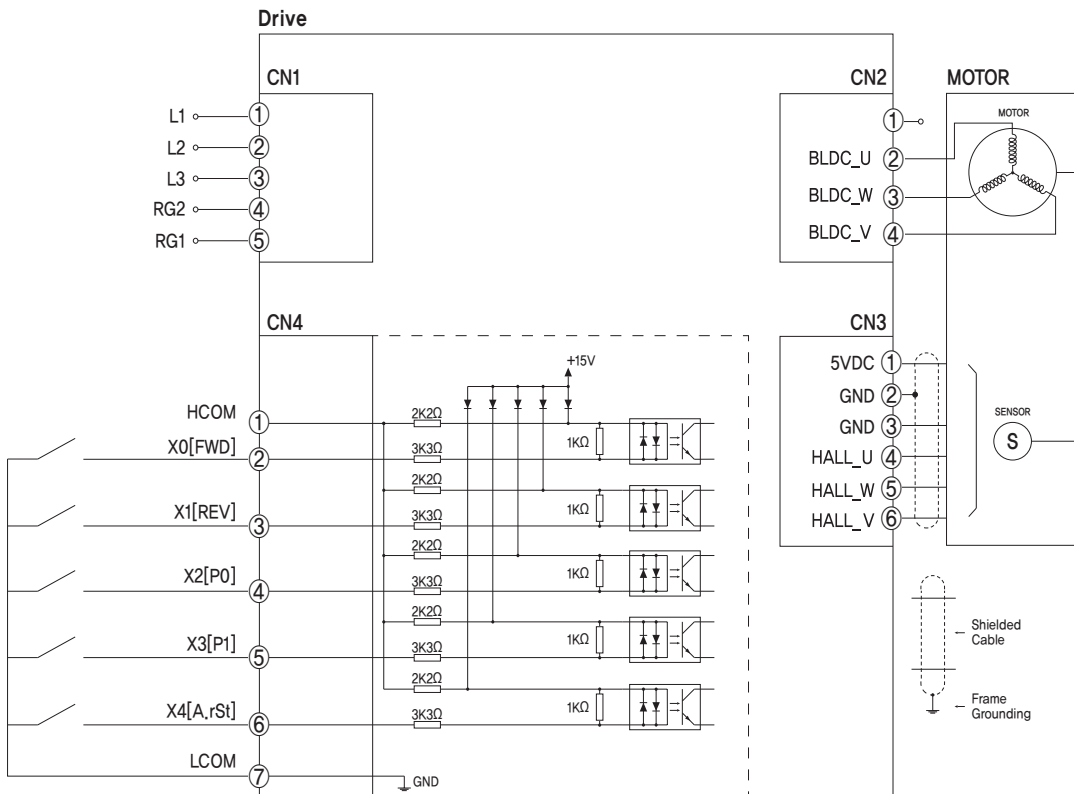

• Connection example for I/O signals and programmable controller

This is connection example when the motor is operated using a transistor output type programmable controller.

SINK LOGIC

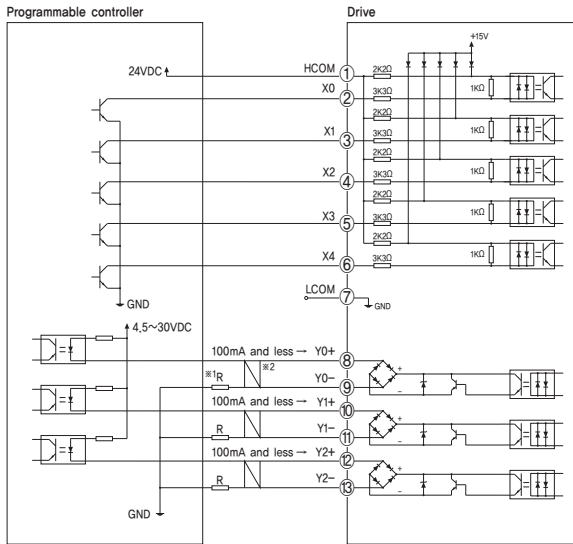

SOURCE LOGIC

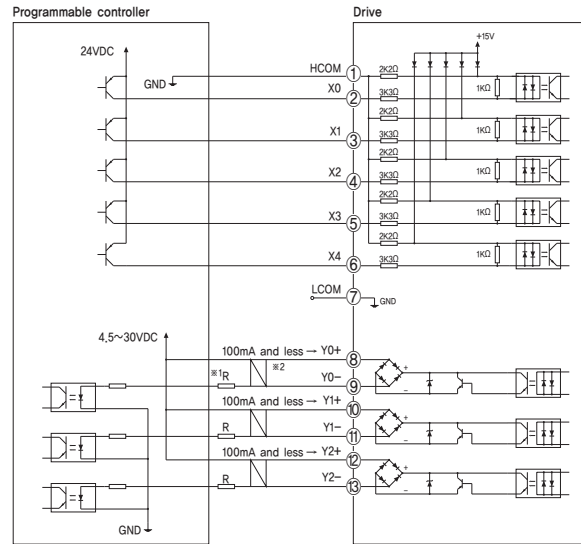

- ※1) Limited resistance
In the case of 24VDC : 680Ω~2.7kΩ(2W)
In the case of 5VDC : 150Ω~560Ω(0.5W)

- ※2) Twisted Pair Shield Cable

Warning

For the Y0, Y1 and Y2, be sure to keep the current value at 100mA or less. If the current exceeds this value, connect the limiting resistor R.

• In the case of using a external controller with a built-in clamp diode

If a external controller with a built-in clamp diode is used, a leakage path may form and cause the motor to operate even when the external controller power is off, as long as the drive power is on. Since the power capacity of the controller is different from that of the drive, the motor may operate when the external controller and drive powers ate turned on or off simultaneously. When power off, turn off the drive power first, followed by the external controller power. When power on, turn off the external controller power first, followed by the drive power.

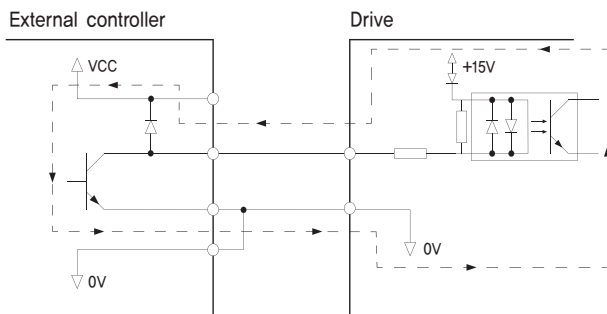

• 8-Speed Operation(In the case of the “external operation signal input” parameter is set to “ON”)

1. Set the operation switch to the “RUN” side.
2. Select the operation data number using the P0, P1 and P2 inputs.
3. When either of the FWD input or REV input is turned ON, the motor will rotate.
4. Change the operation data number using the P0, P1 and P2 inputs.
5. When the FWD input or REV input which has been turned ON is turned OFF, the motor will stop.

Operation data No.	P0	P1	P2	Rotation speed [rpm]
Data 0	OFF	OFF	OFF	1,000
Data 1	ON	OFF	OFF	500
Data 2	OFF	ON	OFF	2,000
Data 3	ON	ON	OFF	1,500
Data 4	OFF	OFF	ON	3,000
Data 5	ON	OFF	ON	2,500
Data 6	OFF	ON	ON	4,000
Data 7	ON	ON	ON	3,500

* Setting speed value is just example, user can change to any speed value.

When changing from the present speed to the new speed, the acceleration time and deceleration time set in the next operation data number are used.

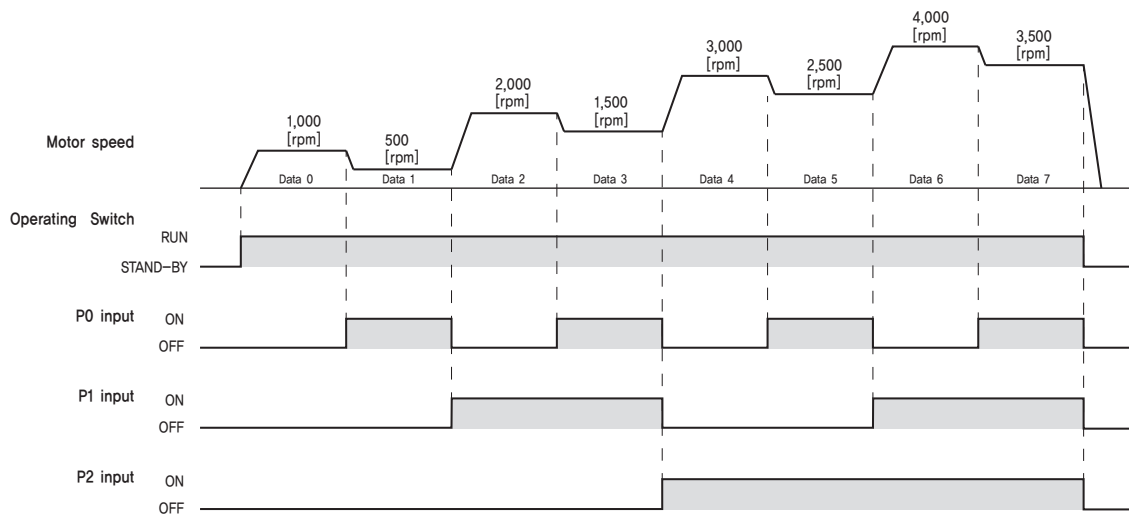

8. Monitor Mode Display

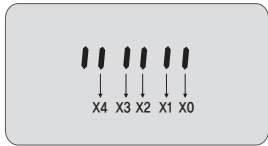
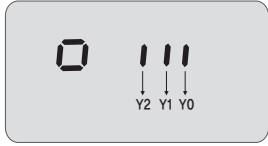
Item	Display	Description
Setting speed display and speed adjustment [rpm]	50	Display the motor setting speed
Actual speed [rpm]	0.	Monitors the actual speed of motor. Monitors the rotation speed of gear output shaft or conveyor transfer speed when the "speed reduction ratio" parameter is set. When the "speed increasing ratio" parameter is set, the actual rotation speed will be increased by external mechanism.
Load factor [%]	L. 0	Monitors the current load factor based on the rated torque being 100%. Displaying value is load factor of motor shaft not gearbox shaft. In case of gearbox mounted motor type, permissible torque is different by reduction ratio of gearbox. Please use checking permissible torque limit of gearbox.
Alarm record display and record reset	ALrc	Monitors the alarm record. You can check alarm record or delete alarm record.
Warning record display and record reset	Wnrc	Monitors the warning record. You can check warning record or delete warning record.
Operation data number	oP.d-	Monitors the operation data No. which is currently selected.
I/O monitor	IO	<p>You can check the ON/OFF status of I/O signal of drive. If the signal is ON, the corresponding LED is ON, if the signal is OFF, the LED is OFF.</p> <p>Input signals</p>  <p>Output signals</p> 

9. Protection functions and LED display

Alarm Code	Alarm type	Cause	Remedial action	Alarm reset
<i>AL--</i>	No alarm record	–	–	–
<i>ALUu</i>	Under voltage	The power supply voltage became lower than approximately 60% of the rated voltage	1. Check the power supply voltage 2. Check the wiring of the power supply cable	Available
<i>ALou</i>	Over voltage	1. The power supply voltage exceeded approximately 120% of the rated voltage. 2. Vertical load (gravitational operation) was driven load inertia was driven.	1. Check the power supply voltage 2. If this alarm occurs during operation, reduce the load or make the acceleration/deceleration time longer.	Available
<i>ALot</i>	Over heat	The temperature inside drive exceeded the alarm detection temperature.	Check the ambient temperature	Available
<i>ALoc</i>	Over current	Excessive current has flown through the drive due to ground fault, etc	Check the damage of wiring between the drive and motor.	Not available
<i>ALSF</i>	Speed feedback	Actual speed and set speed are different.	1. Check the power supply voltage 2. Check the load	Available
<i>ALSS</i>	Sensor error (Hall sensor)	The motor sensor signal line experienced an open circuit during operation or the motor sensor connection.	Check the wiring between the drive and motor.	Available
<i>ALoS</i>	Over speed	The rotation speed of the motor output shaft exceeded approximately 4,800 [rpm]		Available
<i>ALoL</i>	Over load	1. A load exceeding the continuous duty region was applied to the motor for the time exceeded the value set in the "The overload alarm detection time" parameter. 2. The motor was started running under the state that the motor temperature was low.	1. Reduce the load 2. Review the operation pattern such as acceleration/deceleration time.	Available
<i>ALoP</i>	Operation at power-on	When the "external operation signal input" parameter was set to "OFF", while the operation switch was set to the "RUN" side and the power was turned on again.	Set the operation switch to the "STAND-BY" side from the "RUN" side. Next press "S" button.	Available
		When the "external operation signal input" parameter was set to "ON", while the FWD input or REV input was turned ON, the power was turned on again.	1. Set the operation switch to the "STAND-BY" side from the "RUN" side. 2. Turn the FWD input or REV input from ON to OFF.	
<i>ALeE</i>	External Error (From external input signal)	The motor instantaneous stop when EXT-ERROR(Stop) input.	1. Check the EXT-ERROR input. 2. Change status from activated to deactivated.	Available

● System Configuration [30, 60, 120W – 110V]

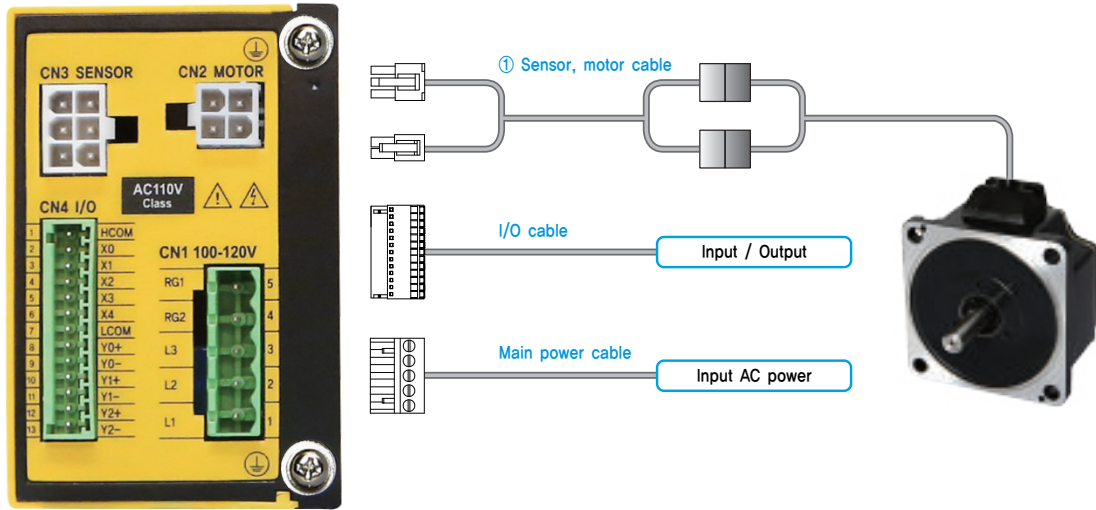

Type	I/O Cable	Sensor Cable	Motor Cable	Main Power Cable
Length supplied	–	50cm	50cm	–
Max. Length	20m	10m	10m	3m

1. Options

Sensor, Motor Cable of 30, 60, 120W

This cable is used connect the wiring between the motor (30W, 60W and 120W) and drive. This cable is single cable with the motor relay cable and sensor relay cable.

① Sensor, Motor Cable

Item	Length [m]	Remark
CSPD-A-□□□F	1, 2, 3, 5, 7, 10	Normal Cable

□ is for Cable Length. The unit is 1m and Max, 10m length.

2. Connector Specifications

Connector specifications for cabling to drive.

Purpose	Item	Part Number	Manufacturer
Power (CN1)	Terminal Block	CPF5,08-05P	STELVIO
Motor (CN2)	Drive side (CN2)	Housing Terminal 5557-04R 5556T	MOLEX
	Motor side	Housing Terminal 5559-04P 5558T	MOLEX
Sensor (CN3)	Drive side (CN3)	Housing Terminal 5557-06R 5556T	MOLEX
	Sensor side	Housing Terminal 5559-06P 5558T	MOLEX
I/O (CN4)	Terminal Block	15EDGKD-13P	DEGSON

※ Above connector is the most suitable product for the drive applied. Another equivalent connector can be used.

● System Configuration [30, 60, 120W – 220V]

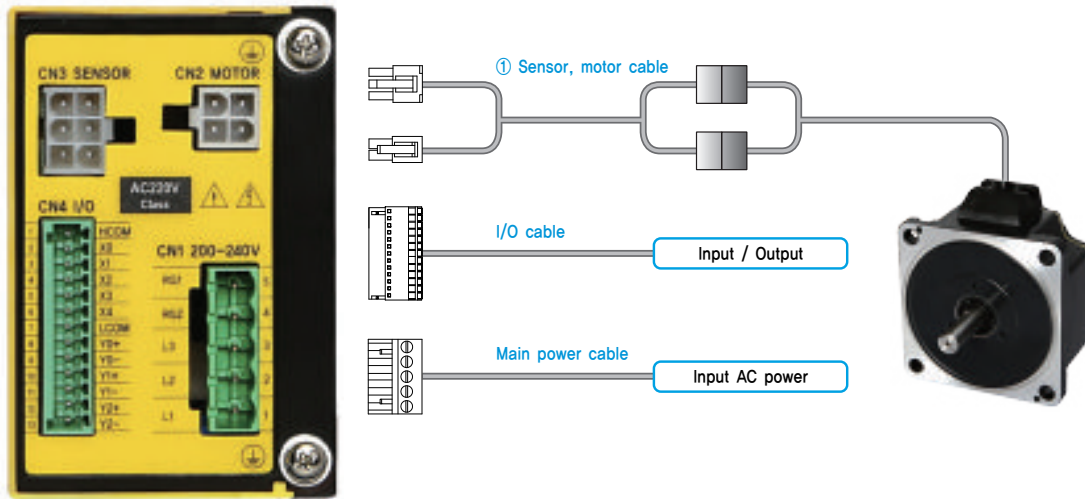

Type	I/O Cable	Sensor Cable	Motor Cable	Main Power Cable
Length supplied	–	50cm	50cm	–
Max. Length	20m	10m	10m	3m

1. Options

Sensor, Motor Cable of 30, 60, 120W

This cable is used connect the wiring between the motor (30W, 60W and 120W) and drive.
This cable is single cable with the motor relay cable and sensor relay cable.

① Sensor, Motor Cable

Item	Length [m]	Remark
CSPD-A-□□□F	1, 2, 3, 5, 7, 10	Normal Cable

□ is for Cable Length. The unit is 1m and Max. 10m length.

2. Connector Specifications

Connector specifications for cabling to drive.

Purpose		Item	Part Number	Manufacturer
Power (CN1)		Terminal Block	CPF5,08-05P	STELVIO
Motor (CN2)	Drive side (CN2)	Housing Terminal	5557-04R 5556T	MOLEX
	Motor side	Housing Terminal	5559-04P 5558T	MOLEX
Sensor (CN3)	Drive side (CN3)	Housing Terminal	5557-06R 5556T	MOLEX
	Sensor side	Housing Terminal	5559-06P 5558T	MOLEX
I/O (CN4)		Terminal Block	15EDGKD-13P	DEGSON

※ Above connector is the most suitable product for the drive applied. Another equivalent connector can be used.

● System Configuration [200, 400W – 220V]

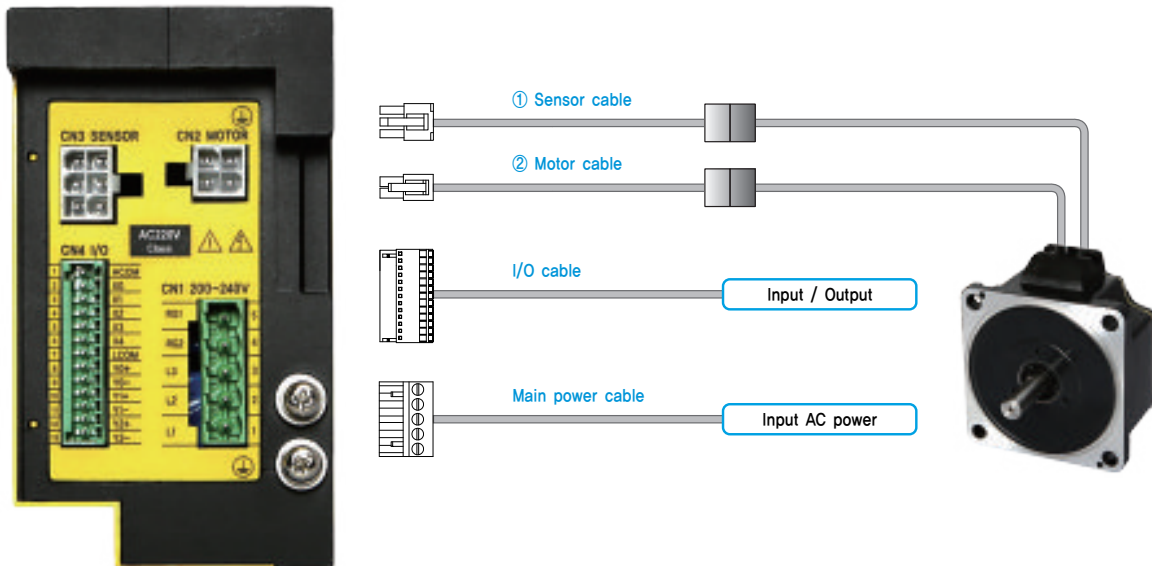

Type	I/O Cable	Sensor Cable	Motor Cable	Main Power Cable
Length supplied	–	50cm	50cm	–
Max. Length	20m	10m	10m	3m

1. Options

Sensor, Motor Cable of 200, 400W

This cable is used connect the wiring between the motor (200W, 400W) and drive.
This cable is each cable (Two line) with the motor relay cable and sensor relay cable.

① Sensor Cable

Item	Length [m]	Remark
CSPD-S-□□□F	1, 2, 3, 5, 7, 10	Normal Cable

□ is for Cable Length. The unit is 1m and Max. 10m length.

② Motor Cable

Item	Length [m]	Remark
CSPD-M-□□□F	1, 2, 3, 5, 7, 10	Normal Cable

□ is for Cable Length. The unit is 1m and Max. 10m length.

2. Connector Specifications

Connector specifications for cabling to drive.

Purpose	Item	Part Number	Manufacturer
Power (CN1)	Terminal Block	CPF5,08-05P	STELVIO
Motor (CN2)	Drive side (CN2)	Housing Terminal 5557-04R 5556T	MOLEX
	Motor side	Housing Terminal 5559-04P 5558T	MOLEX
Sensor (CN3)	Drive side (CN3)	Housing Terminal 5557-06R 5556T	MOLEX
	Sensor side	Housing Terminal 5559-06P 5558T	MOLEX
I/O (CN4)	Terminal Block	15EDGKD-13P	DEGSON

※ Above connector is the most suitable product for the drive applied. Another equivalent connector can be used.

External Wiring Diagram [110V Drive]

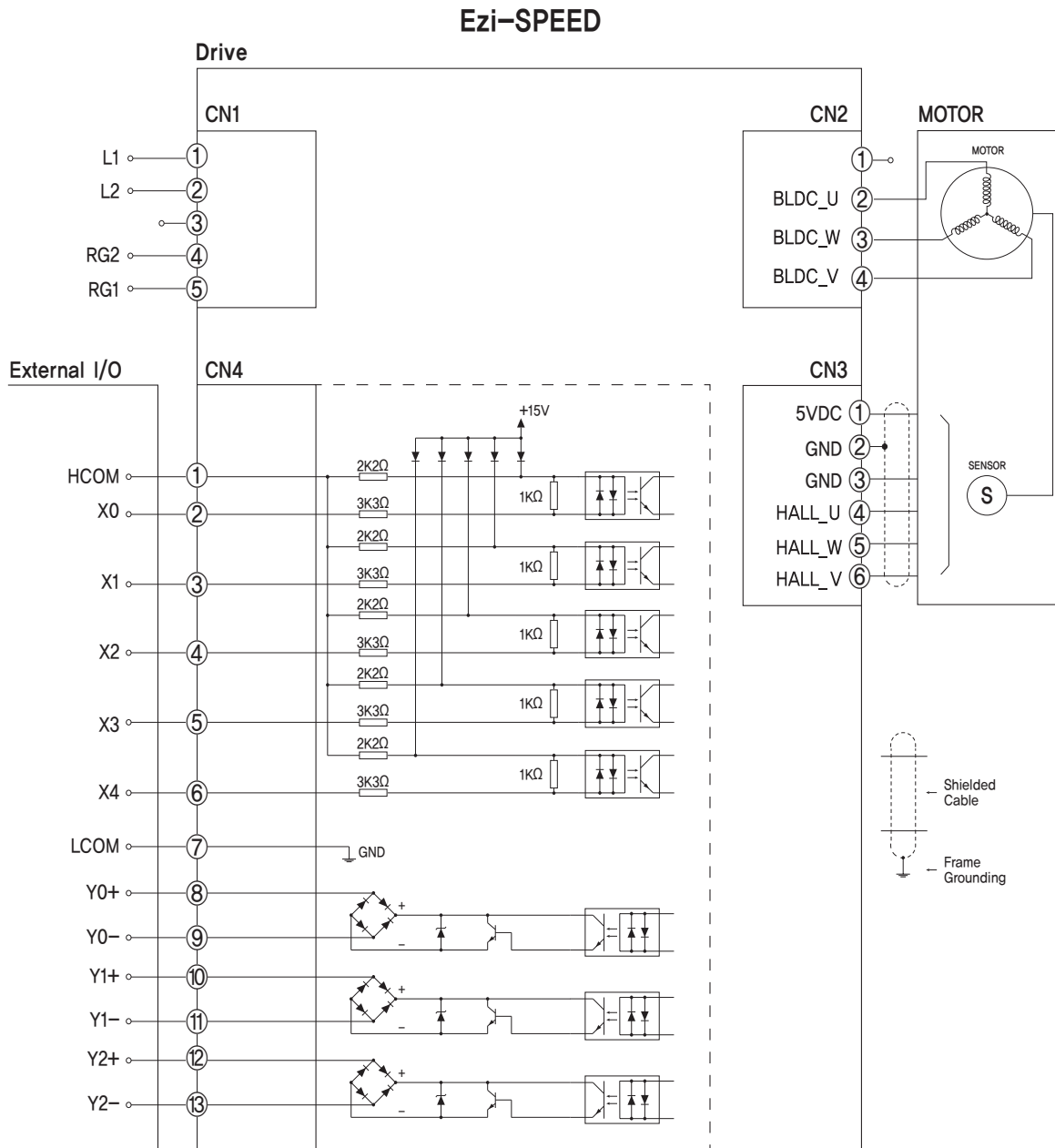

※ When connects I/O cable between controller and drive, please turn off the power of both controller and drive, in order to protect the drive from any damage.

CAUTION

Please refer to the Manual when connects motor extension cable.
Careful connection will be required to protect the drive from any damages.

External Wiring Diagram [220V Drive]

Ezi-SPEED

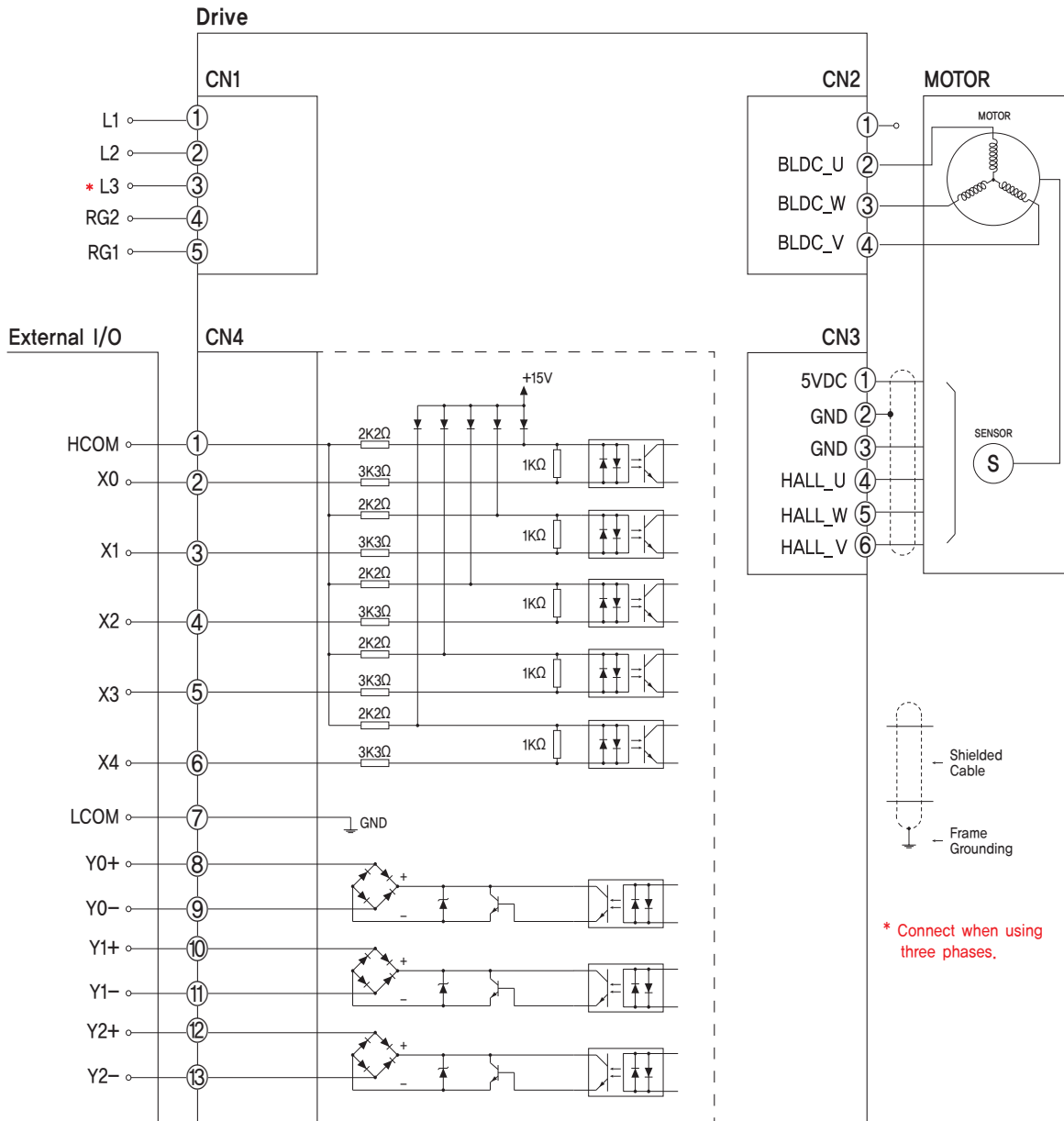

FASTECH Ezi-SPEED

※ When connects I/O cable between controller and drive, please turn off the power of both controller and drive, in order to protect the drive from any damage.

CAUTION

Please refer to the Manual when connects motor extension cable.
Careful connection will be required to protect the drive from any damages.

MEMO



Fast, Accurate, Smooth Motion

DISTRIBUTED BY:

 **บริษัท นานดีอินเตอร์เทรด จำกัด**
NANDEE INTER-TRADE CO., LTD.

Tel : 0-2675-8230 (Auto), 0-2675-8240 (Auto)

Fax : 0-2212-1448, 0-2213-0360

 : [nandeeintertrade](https://www.facebook.com/nandeeintertrade)

 : [@nandeeintertrade](https://line.me/tv/@nandeeintertrade)

 : marketing@nandee.co.th

 : www.nandee.co.th

