



ECORICH

HYBRID HYDRAULIC UNIT **ECORICH**

Surpassing IE4 class

Exceeds standard of high efficiency motor regulation.

All Models CE Standard Compliant

**New Models
Added**

**400 v
specifications**



Highly efficient IPM motors now incorporated
for substantial energy savings and low heat generation

DAIKIN INDUSTRIES, LTD.

Oil Hydraulic Division
Oil Hydraulic Equipment

Features

Explained in an easy-to-understand video!

URL http://www.daikinpmc.com/mv/debut_of_new_ecorich.html



- “ECORICH”, a hybrid hydraulic system that realized the world’s first fusion of hydraulics technology with Daikin’s exceptional air conditioning motor/inverter technology, has been a trend setter for energy savings in the hydraulics field.
- “ECORICH” has now undergone a model change involving incorporation of highly efficient IPM motors. The significant improvement in energy savings and low heat generation contribute to greater plant energy savings.

Fundamental principle of the IPM motor

With a rare-earth permanent magnet deeply embedded in the rotor, the IPM motor uses an electromagnetic structure that maximizes magnetic torque (attractive/repulsive force between the coil and permanent magnet) and reluctance torque (force of the coil that attracts iron). This structure achieves high torque and maximum efficiency while suppressing heat generation.

Structure of the IPM motor

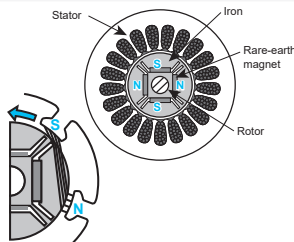

IPM motor drive system (Interior permanent magnet synchronous motor)

Since the magnetic field lines at the south pole side are made longer than those at the north pole side, the magnetic field lines at the south pole will try to shorten like a stretched rubber band contracts, resulting in rotational force due to reluctance torque in the direction indicated by arrow.

“Double torque” improves the energy-saving effect.

Combining two rotational forces, “magnetic torque” generated by a powerful neodymium magnet^{*1} and “reluctance torque”^{*2}, generates more power with less electricity.

Powerful neodymium magnets, the key to this improved energy-saving effect!

Ferrite magnet

Neodymium magnet



Neodymium magnets provide more power – substantially more than the ferrite magnets in general use.

*1: A compound of neodymium (Nd, rare-earth element), iron (Fe), and boron (B). Neodymium magnets are known to have superior magnetic properties.

*2: Rotational force generated by attractive force (reluctance = magnetic resistance) between iron and a magnet.

Feature 1

Energy savings / low heat generation

* Figures compared to conventional ECORICH design 30 series models

Power consumption: Reduced by additional 30%

The highly efficient IPM motor surpassing IE4 class further improves the energy-saving effect of the unit.

Oil Temperature: Reduced by additional 5 °C

The user-friendly hydraulic unit realized by suppressing oil temperature rise reduces thermal influence on the machine, improves the environment at the machining site, and prevents degradation of hydraulic oil, extending the oil replacement interval.

Comparison of power consumption

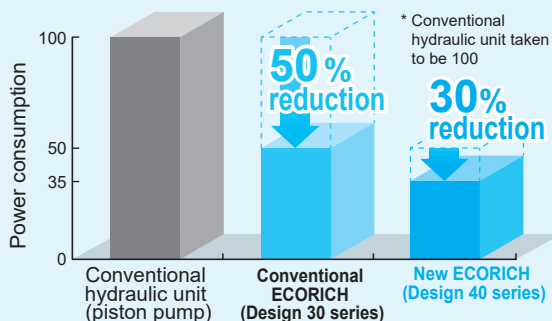

Feature 2

Compact / lightweight

* Figures compared to conventional ECORICH design 30 series models

A more compact and lightweight unit offers a reduced footprint for easier installation.

Footprint: Reduced by 9% (all models)

Mass: Reduced by 40% (EHU1404/2504)

Feature 3

Environmental resistance

* Figures compared to conventional ECORICH design 30 series models

A more reliable controller improves environmental adaptability.

Max. ambient temperature:
Increased from 35°C to 40°C

Dustproof and waterproof protection rating: IP44

Tank capacity:
Increased from 10 L to 18 L

Achieves greater resistance to contamination and reduced oil level fluctuation.

Feature 4

Excluded from high-efficiency motor regulations

Hassle-free design is assured by:

- Eliminating the need to replace motors for each destination
- Eliminating the need for design changes in accordance with amendments to the regulations

Feature 5

All models CE standard compliant

This facilitates CE approval of the machines.

Feature 6

ECORICH with 400V specifications was developed without a transformer

Same size as 200 V specifications, with installation / piping compatibility
Compact and space-saving due to transformerless configuration

Nomenclature



1 Model No.

- EHU: ECORICH Series

2 Maximum flow rate

- 14: 15.2 L/min
- 25: 25.1 L/min
- 30: 28.5 L/min

3 Maximum operating pressure

- 04: 4 MPa
- 07: 7 MPa

4 Design No.

- Design 40 series (Incremented at model changes)

5 Controller option (s)

(If there are multiple requirements, combine in the order Y, C, S)

- Y: 400 V specifications (no transformer, applicable to EHU3007 only)
- C: With RS422/485 communications function
- S: With separated power supplies for power and control lines
- N: No controller option and with unit options

6 [Unit option (up to 6 letters of the alphabet, a combination of those tabled below, in alphabetical order when combined)] or [Non-standard control number (3-digit number)]

- Unit options

Code	Description	Code	Description
F	Water fill test compliant tank	L	Level switch ("NO" contact)
M	Water leak test compliant tank	H	Level switch ("NC" contact)
J	Magnet separator	P	Temperature switch ("NC" contact)
B	Oil filler port (yellow cap)	K	Thermometer
G	Oil level gauge guard (yellow)	A	Mounting conversion plate for compatibility
E	Oil level gauge guard (black)		

- Examples of model codes

Controller option	Unit option	Model code
None	None	EHU1404-40
Featured	None	EHU1404-40-CS
None	Featured	EHU1404-40-N-AB
Featured	Featured	EHU1404-40-CS-AB

Detailed Explanation of Unit Options

Code	Description	Option model code (sold separately)	Notes
F	Water fill test compliant tank	-	These cannot be retrofitted, so please specify them when ordering the unit.
M	Water leak test compliant tank		
J	Magnet separator	E-MSB-110-01	-
B	Oil filler port (yellow cap)	E-MSA-V22-F	The standard color is dark blue.
G	Oil level gauge guard (yellow)	E-GUARD-Y	Select either of these options.
E	Oil level gauge guard (black)	E-GUARD-B	
L	Level switch ("NO" contact, ON when oil level at or below 11 L)	E-DLSN-130L-A-10	Select either of these options. Not mountable on the T port
H	Level switch ("NC" contact, OFF when oil level at or below 11 L)	E-DLSN-130L-B-10	
P	Temperature switch ("NC" contact, OFF when oil temperature is 60°C or lower)	E-MQT83PD-L60X1-10	Select either of these options. Prepare a compatible bushing.
K	Thermometer	E-RBT-ST-R1/4-100-6X150	
A	Mounting conversion plate for compatibility	E-EHUPATE	Used to secure the body of the unit using the fixing holes for conventional ECORICH units (Design 30 series).

(T2) Rp½ (temperature switch or thermometer) **P** or **K**

(DR2) Rp½ (level switch) **L** or **H**

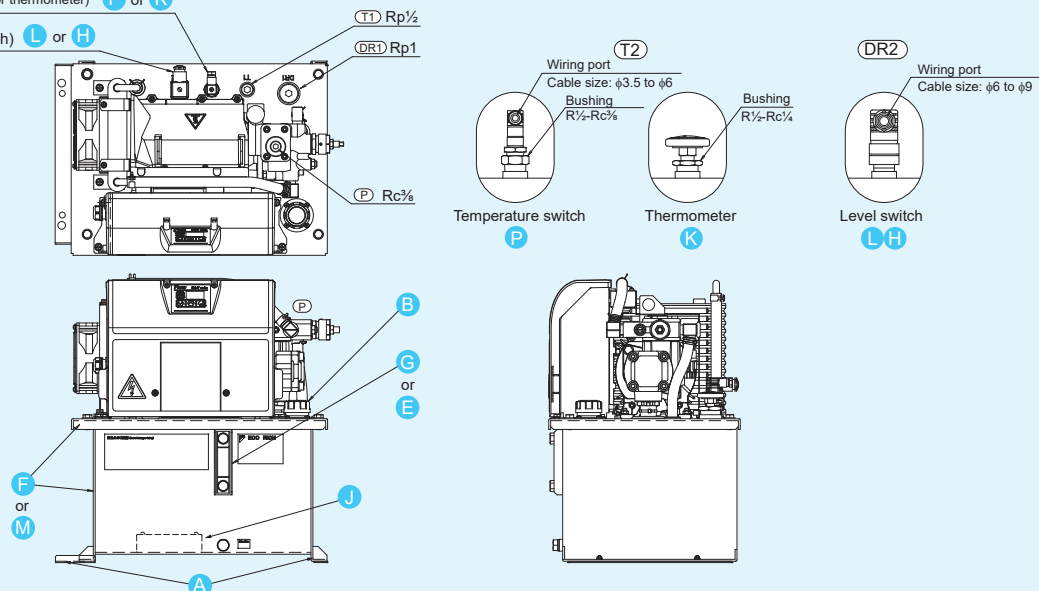

■ Pressure – Flow rate characteristics

■ EHU1404

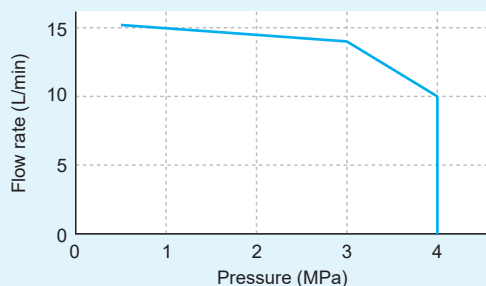

■ EHU2504

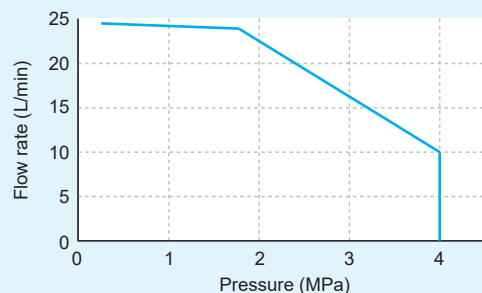

■ EHU2507

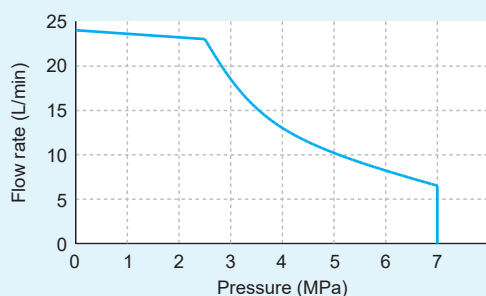

■ EHU3007

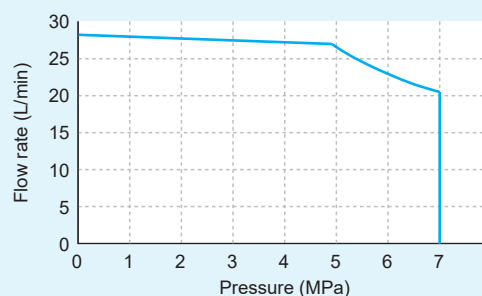

* The graph shows actual flow rates (representative values).

* Operating flow rate at the maximum pressure in continuous operation: 5 L/min maximum

■ Specifications

Model code	EHU1404-40	EHU2504-40	EHU2507-40	EHU3007-40	EHU3007-40-Y		
Maximum operating pressure (MPa)	4.0			7.0			
Operating pressure adjustment range (MPa)	1.5 to 4.0			1.5 to 7.0			
Maximum flow rate ¹ (L/min)	15.2	25.1		28.5			
Operating flow rate adjustment range (L/min)	2.5 to 15.2	3.5 to 25.1		3.5 to 28.5			
Motor capacity (equivalent kW)	0.75	1.5	2.2	2.8			
Tank capacity (L)	18						
Power supply voltage	3-phase, AC 200 V (50 Hz) / AC 200 V (60 Hz) / AC 220 V (60 Hz) (Permissible voltage fluctuation: ±10%)				3-phase, AC 380 V (50 Hz) / AC 400 V (60 Hz) / AC 460 V (60 Hz) (Permissible voltage fluctuation: ±10%)		
Rated current (A)	200 V/50 Hz	6.0	7.0	4.7	10.3	380 V/50 Hz	7
	200 V/60 Hz	5.9	7.0	4.5	10.3	400 V/60 Hz	6.5
	220 V/60 Hz	5.5	6.7	4.3	9.7	460 V/60 Hz	6
No-fuse breaker capacity (A)	15				10		
External input signal	3 channels, photo coupler insulation, DC 24 V (maximum of DC 27 V), 5 mA per channel						
External output signal	Digital output	1 channel, photo coupler insulation, open collector output, DC 24 V, 50 mA maximum per channel					
	Contact output	1 channel, relay output, contact capacity: DC 30 V, 1 A (resistance load), 1 common contact					
Usable oil ²	General petroleum-based hydraulic oil (R&O) / Wear-resistant hydraulic oil • Viscosity grade: ISO VG32 to 68 • Viscosity range: 15 to 400 mm ² /s • Contamination: Within NAS class 10						
Tank oil temperature	0 to 60°C (Recommended operating temperature range: 15 to 50°C)						
Operating ambient temperature	0 to 40°C						
Storage ambient temperature	-20 to 60°C						
Operating ambient humidity	85% RH maximum (no condensation)						
Waterproof protection rating	IP44						
Installation site	Indoors (Be sure to secure with bolts, etc.)						
Altitude	1,000 m maximum						
Standard coating color	Black						
Mass (hydraulic oil excluded) (kg)	26			29			

*1: • The maximum flow rate is the theoretical value, not the guaranteed value.

• Refer to the Delivery Specifications (outside drawing) for detailed specifications.

• This hydraulic unit is equipped with built-in safety valves.

*2: • Use of hydraulic oils other than mineral-oil base type (e.g. hydrous/synthetic), water-glycol hydraulic oil for example, is prohibited.

External Dimension Diagram

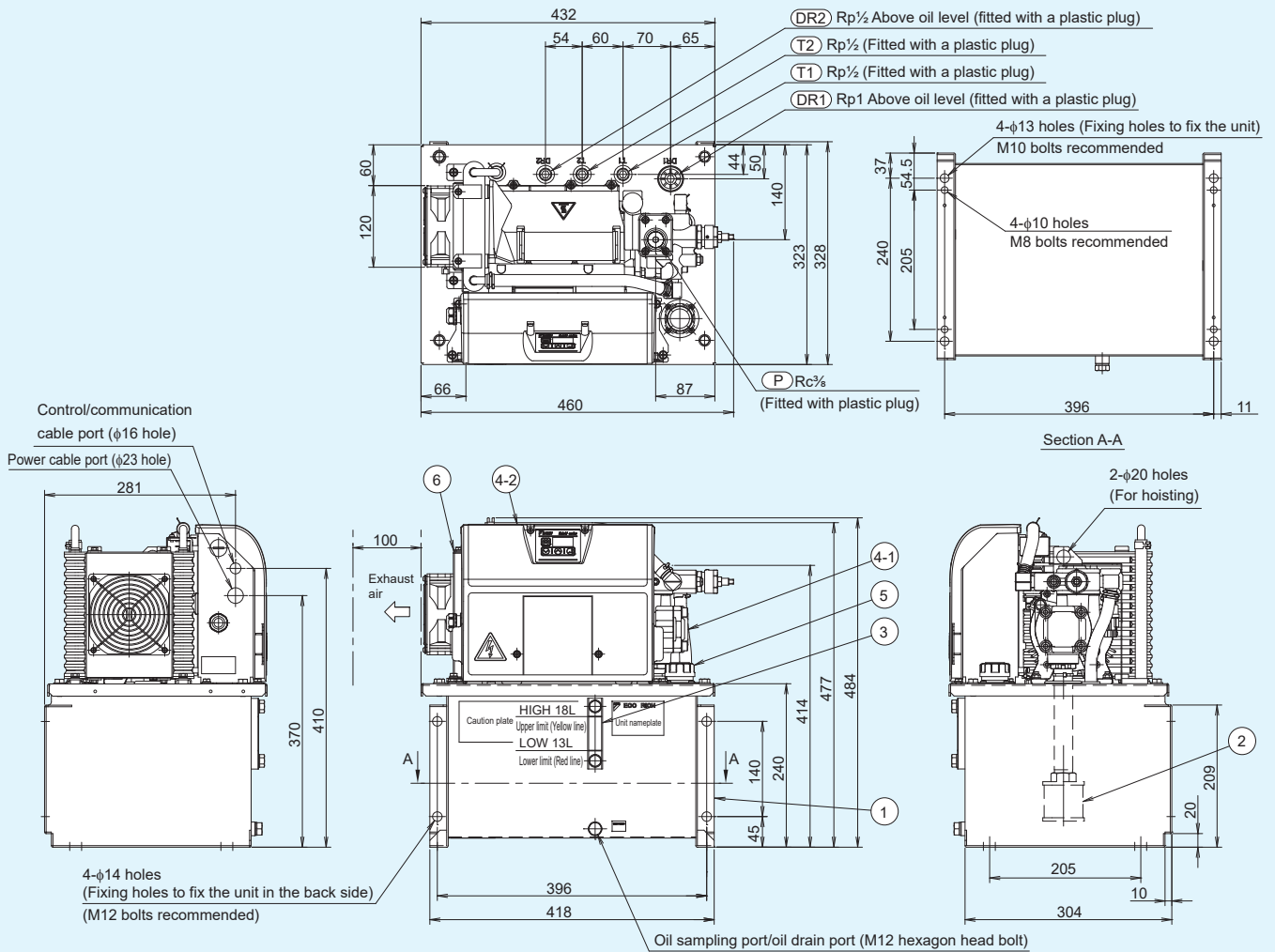

Hydraulic Circuit Diagram

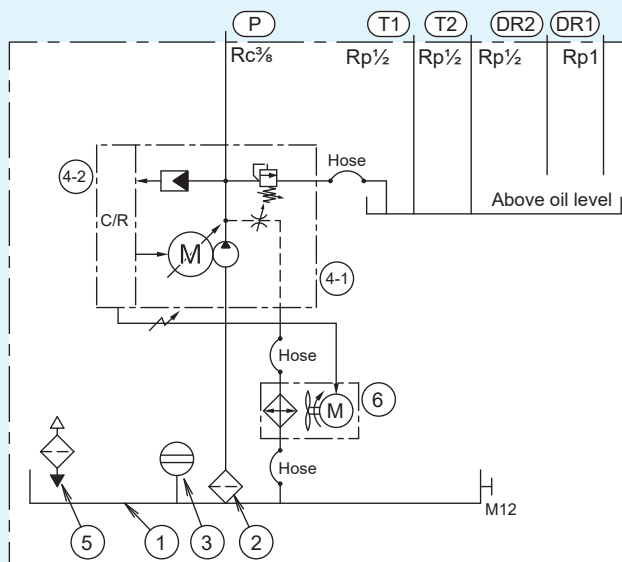

List of parts

Part No.	Name	Quantity
1	Oil tank	1
2	Suction strainer	1
3	Oil level gauge	1
4-1	Motor pump equipped with IPM motor	1
4-2	Control unit	1
5	Oil filler port with air breather	1
6	Oil cooler	1

Wiring Guide

Internal terminal layout (with the controller cover open)

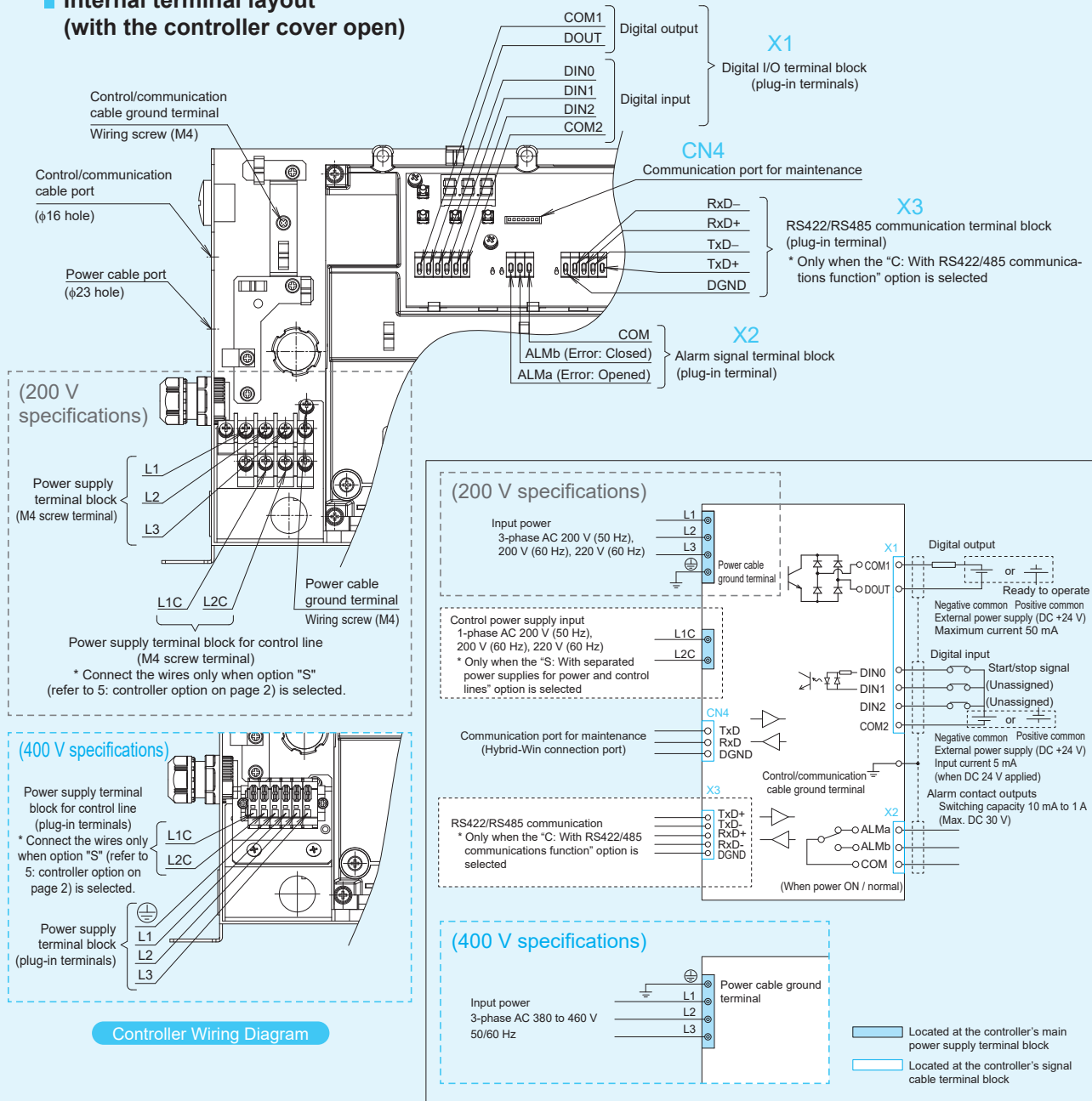

Main power supply connections

Connect a 3-phase AC power supply to the power supply terminals (L1, L2 and L3), and connect the ground wire to the power supply ground terminal.

Cable specifications	Cable size	Recommended cable	Recommended crimp terminal	Recommended cable clamp
CE	1.5 mm ² or greater	CE362 1.5 mm ² × 4 wires (KURAMO ELECTRIC)	Round tongue type (200 V specifications) RBC2-4 (from J.S.T. Mfg.)	OHM ELECTRIC OA-W1611 Applicable cable outer diameter: φ9 to φ11
VCT	2 mm ² or greater	VCT362 2 mm ² × 4 wires (KURAMO ELECTRIC)	Straight type (400 V specifications) 216-204 (1.5 mm ²) 216-205 (2 mm ²) (from WAGO)	OHM ELECTRIC OA-W1613 Applicable cable outer diameter: φ11 to φ13

I/O signal terminal connections

Connect wires to the I/O signal terminal block as shown in the table at the top of page 6.

Cable size	Recommended cable	Recommended cable clamp
0.3 to 0.5 mm ² (AWG20 to 22)	KVC-36SB 0.3 - 0.5 mm ² (KURAMO ELECTRIC)	OHM ELECTRIC OA-W1611 Applicable cable outer diameter: φ9 to φ11

Digital I/O / alarm signal terminal block

Terminal block	Terminal code	Type	Signal name	Remarks
Digital input/output	COM1	Digital output	Common digital output	This common terminal can be either positive or negative.
	DOUT	Digital output	Digital output	Outputs completion signals or motor operation signals. (Varies depending on the parameter setting.)
	DIN0	Digital input	Digital input 0	Runs or stops the unit. (Run/stop operation upon signal input can be selected with a parameter.)
	DIN1		Digital input 1	(Reserved)
	DIN2		Digital input 2	(Reserved)
COM2	Digital input	Common digital input	This common terminal can be either positive or negative.	
Alarm signal	ALMa	Contact output	Alarm output, "NO" contact	When the power supply is ON and the status is normal, this is "closed", and when the pressure switch has actuated or an alarm or warning has occurred, it is "open". (Varies depending on the parameter setting.)
	ALMb		Alarm output, "NC" contact	This is "open" when the status is normal.
	COM		Common alarm output	Common

ECORICH Handling Precautions

These are the minimum requirements for use of the ECORICH. For details, refer to the unit's Instruction Manual.

- **Ambient conditions**
 1. Ambient temperature: 0 to 40°C, ambient humidity: 85% RH maximum (with no condensation), altitude: 1,000 m maximum, to be used indoors.
- **Hydraulic oil**
 1. Use mineral-oil base hydraulic oil.
Use of hydraulic oils other than mineral-oil based type (e.g. hydropsynthetic) is prohibited.
 2. Use hydraulic oil equivalent to ISO VG32 to 68. Keep the viscosity of the hydraulic oil within the range from 15 to 400 mm²/s, and keep tank oil temperatures within the range from 0 to 60°C.
 3. Keep contamination within NAS class 10.
- **Installation and piping**
 1. The unit is a stationary type. Fix it with bolts on a level location that is free of vibration.
 2. Keep obstacles that will obstruct air intake and emission at least 100 mm away from the end face of the unit. Install the unit at a location with good air flow so that heated air can be vented.
- **Electric wiring**
 1. Install a no-fuse breaker and a ground fault interrupter compliant with European Standard EN60947-2 in the main power supply of ECORICH, to protect the electrical circuits against shorting and overcurrent, and to prevent electric shocks.
 2. Use suitable electric cable in accordance with the power supply capacity. In addition, connect the cables correctly in accordance with the wiring guide.
 3. Provide a ground connection in compliance with the law in the relevant country. Connect the grounding wire directly with no breaker in the line.
 4. Take care not to allow waste metal such as screws and wiring debris, or combustible matter such as wood waste or oil, to enter inside the control unit.
 5. Use a commercial power supply for the power source. The use of an inverter power supply may cause burn damage to the unit.
 6. Before accessing the interior of the control unit, check that the unit's power supply has turned OFF and then wait at least 5 minutes.
 7. For the power supply wiring, use round tongue type terminals for 200 V specifications and straight type terminals for 400 V specifications.
- **Other precautions**
 1. If a failure occurs in the hydraulic unit, the system indicates an alarm and terminates. If a failure or malfunction of this unit is expected to cause death or pose a danger to human beings, adopt appropriate safety measures in the facilities.
 2. Turning the power supply ON/OFF frequently will significantly shorten the life of the controller. Use the start/stop digital inputs to start/stop this hydraulic unit. Leave an interval of at least 5 minutes between operation stops invoked by turning the power supply ON/OFF. Also, when starting and stopping the unit using the start/stop signals, leave an interval of at least 0.5 seconds between a stop command and restarting.
 3. It takes approximately 3 seconds for this hydraulic unit to start up after being powered ON. Depending on the piping conditions, the unit may take longer to increase the pressure to the pressure switch's preset level, resulting in pressure switch signal output. In this case, set the machine up so that it will not accept this alarm output during this period.
 4. Operating flow rate at the maximum pressure in continuous operation: Should be 5 L/min or less.

Compliance of 400 V Specifications with EU Directives

We confirmed that the EHU 400 V unit is in compliance with the EU directive on the wiring connection to the right. As SPD and NF are not equipped on the EHU 400 V unit as standard, prepare SPD and NF to install on site if the machine would require those parts under the following conditions.

- Retrofitting the EHU 400 V unit on an existing machine
- Requirement for compliance with the EU Directive applicable to the EHU 400 V unit itself.

- EMC Directive: 2014/30/EU
- Compliance standard: EN61800-3:2004 (Second environment / PDS Category "C3")

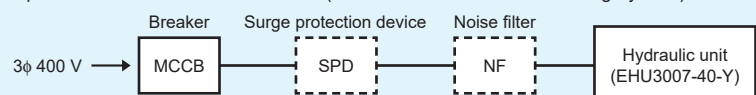

- Noise filter (NF) Daikin model: PM-SNF12 [Manufacturer: SCHAFFNER
Part No.: FN3025HP-10-71]
- Surge protection device (SPD) Daikin model: PM-SPD01 [Manufacturer: OTOWA ELECTRIC CO., LTD.
Part No.: LT-C35G102W]

ECORICH

HYBRID HYDRAULIC UNIT ECORICH



บริษัท นานดีอินเตอร์เทรด จำกัด
NANDEE INTER-TRADE CO., LTD.

314,316,318,320,322 ซอยจันทน์ 32 ถนนจันทน์ แขวงทุ่งวัดดอน เขตสาทร กทม. 10120

Tel : 0-2675-8230 (Auto), 0-2675-8240 (Auto) Fax : 0-2212-1448, 0-2213-0360

LINE : @nandeeintertrade

f : nandeeintertrade

✉ : marketing@nandee.co.th

🌐 : www.nandee.co.th

LINE @

