



# OIL COOLING UNIT

Circulating type, for cooling oil

AKZ14A, AKZ32A, AKZ43A, AKZ56A, AKZ90A

*High-accuracy, Energy-saving, Compact  
Transformerless 400 V specifications  
also available  
Suited to all applications!*

## I N D E X

Features	Pages 1 and 2
Principle and Overall System Diagram / Piping System Diagram	Page 3
Nomenclature	Page 4
Specifications and Operating range	Pages 5 to 8
Cooling Capacity Characteristic Chart	Pages 9 and 10
External Dimension Diagram	Pages 11 to 20

## Optional Parts

Thermistor	Page 21
Option Board for Communication	Page 22

## Supplementary Information

Control Panel Operation Mode/ Setting Method	Pages 23 and 24
Electric Wiring Diagram	Page 25
Electric Wiring Connection Instruction	Page 26
Notes for Handling	Pages 27 to 29
Selection Method	Page 30
Time Line	Page 31



**NEW**

**Oil Cooling Unit 10 Series**

**DAIKIN INDUSTRIES, LTD.**  
Oil Hydraulic Division  
Oil Hydraulic Equipment

# OIL COOLING UNIT

## For cooling oil | Circulation type

AKZ14A, AKZ32A, AKZ43A, AKZ56A, AKZ90A



Features

### Features

#### Acclaimed high-accuracy temperature control

- Acclaimed high-accuracy  $\pm 0.1^{\circ}\text{C}$  oil temperature control
- The cooling capacity resolution in the low-load range has been improved by optimal control of the compressor/inverter and electronic expansion valve.
- $\pm 0.1^{\circ}\text{C}$  oil temperature control realized over a load range from 0% (no load) to 100%.

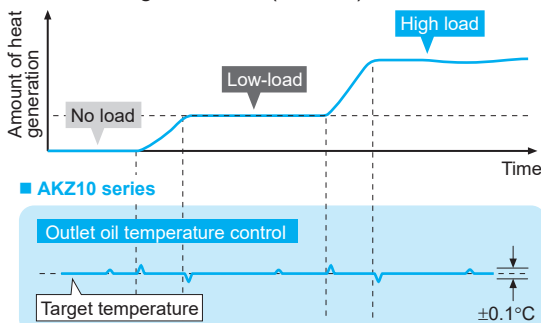

Note: Pattern diagram with the heating load stabilized at 0 - 100%

#### Reduced environmental load

- Complies with environmental regulations, e.g. by adopting printed circuit boards with lead-free solder.

#### Achieves high energy-saving performance

- Achieve high energy-saving performance with the adoption of a DAIKIN original IPM motor and inverter.
- The power consumption can be checked on the control panel.

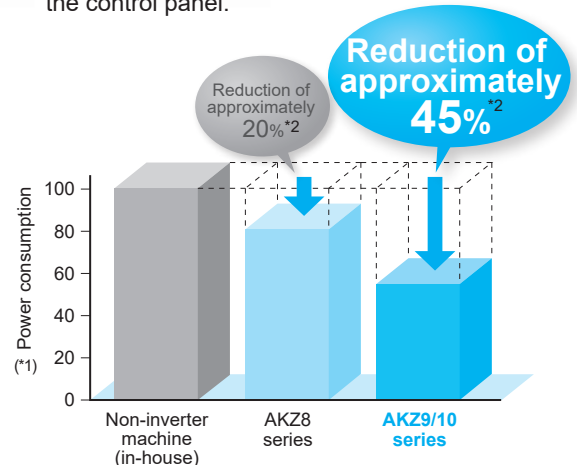

\*1. The comparison reduction costs are based on a Daikin non-inverter system and are shown as 100% consumption.

\*2. Measured during the operation patterns for DAIKIN models

#### Lightweight, compact, transformerless 400 V specifications now available <sup>\* Comparison of AKZ439-047 and AKZ43A-500 (units: mm)</sup>

- The dimensions are the same as standard models, so no design changes are needed for different voltages.
- Both volume and mass are substantially lower than the 9 series.

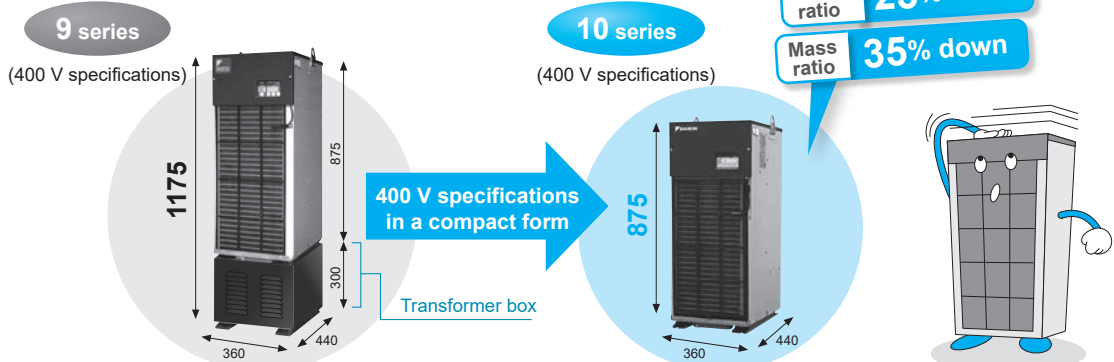



## Features

### Reliable in challenging factory environments

- The control panel ingress protection is equivalent to an IP54 rating.
- Electronic components resistant to sulfidation have been incorporated.
- The specifications for withstanding vibration during transport are matched to actual situations.

### Offering 6 types of standard option models in addition to the standard model to achieve short delivery

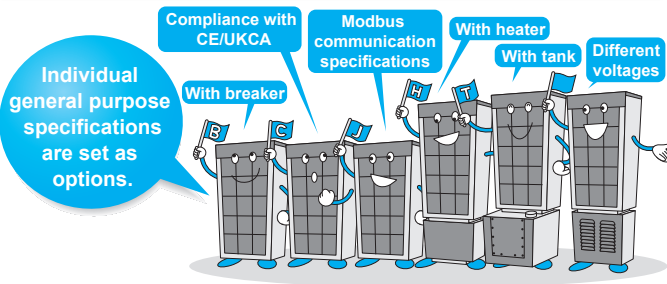

### Simple monitoring of the operating status

- The room temperature, inlet and outlet oil temperatures and other internal data can be monitored at a personal computer using Hybrid-Win\*. This data can be displayed collectively, making it easy to grasp the operating status.

\* Hybrid-Win is utility software to monitor the internal status of DAIKIN hybrid systems using a PC. The software and its instruction manual can be downloaded from the website "https://www.hyd.daikin.com" free of charge by completing the user registration process.

\* The communications cable and the monitor harness must be purchased separately.

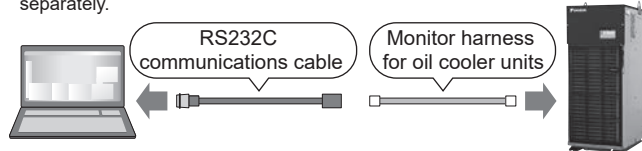

### Superior functionality remains unchanged

- **Refrigerant gas shortage detection function**  
When the refrigerant gas leak status occurs (cooling disabled), alarm signals are output. Prevents damage to the machine and machining defects.
- **Temperature warning function**  
A warning signal can be output when the targeted oil temperature or room temperature is out of the user-selected setting range.
- **Autotuning function**  
An autotuning function that automatically sets the control gain according to the system installed (tank oil volume, piping, etc.) greatly reduces adjustment time at the trial run.
- **999-hour timer function (ON timer)**  
The operation start time can be set in a range between 0 and 999 hours (in hour units).
- **Predictive maintenance function**
  - A warning signal is output to notify that maintenance is required when the air filter or condenser becomes clogged.
  - When a thermistor fault (control failure) occurs, emergency operation is possible using another operation mode. This minimizes effects due to line stoppages.

### Easy to operate, and easy to maintain

- Easy-to-operate control panel that shows power consumption
- Plug-in terminal block makes tools unnecessary when connecting signals.
- Air filter structure that resists condenser clogging due to oil mist

## Applications

### Examples of major applications

Machine tools ..... Machining center, NC lathe, grinding machine, NC specialized machine, NC electric discharge machine, etc.  
Industrial machine ..... Molding machine, press, etc.

#### Cooling of hydraulic oil

- Temperature (viscosity) control**
- Prevention of deterioration of hydraulic oil (Longer life)
  - Stabilized operation of actuators

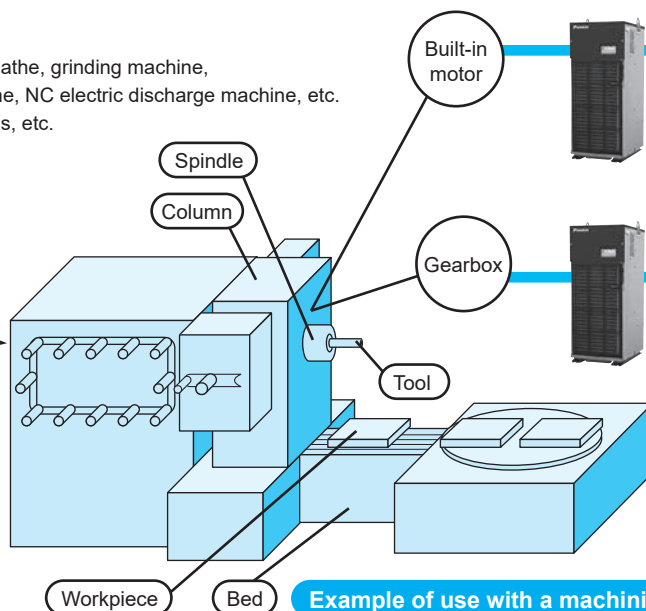
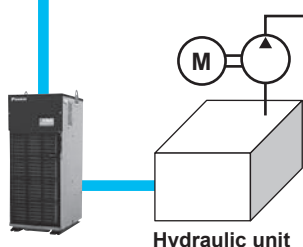

#### Cooling of cooling oil

##### Cooling of periphery of built-in motor

- Minimizing the thermal displacement of the spindle
- Minimizing the thermal displacement of the column
- Preventing temperature rise of the motor coil

#### Cooling of lubricant

##### Cooling inside the gearbox

- Minimizing the thermal displacement of the spindle
- Minimizing the thermal displacement of the column

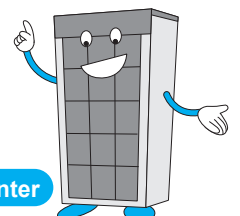

### Example of use with a machining center

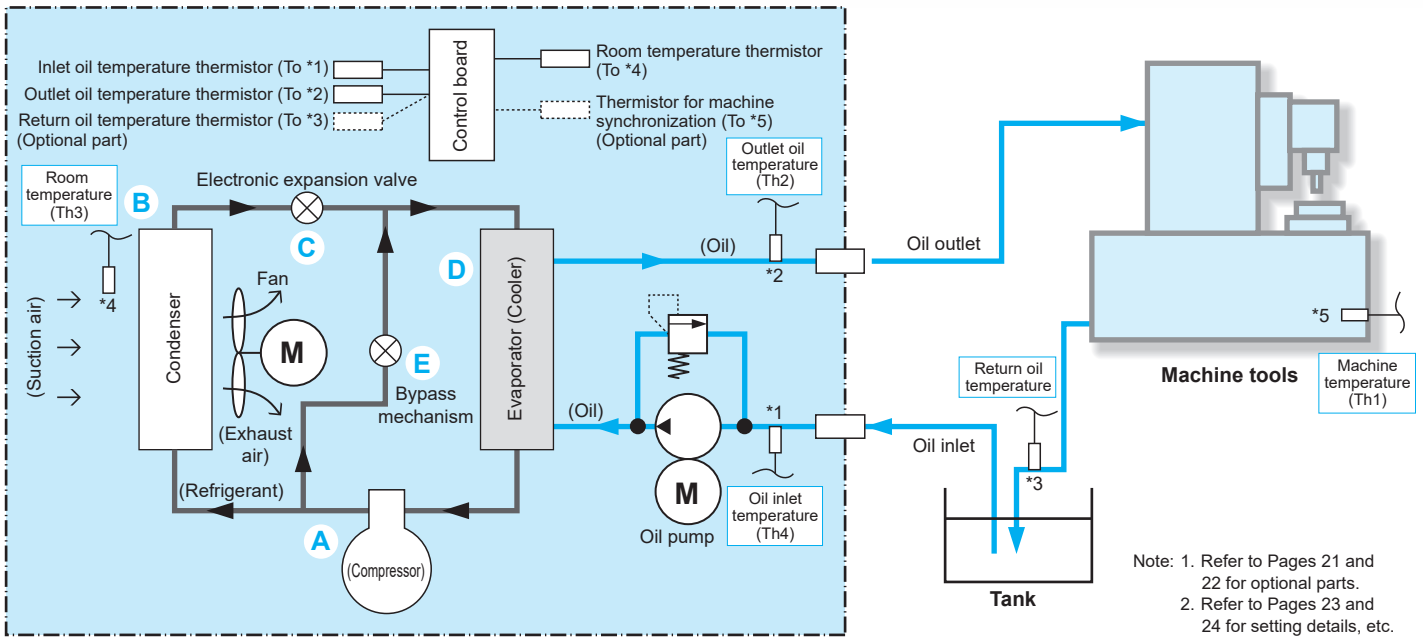

[Refrigerating cycle]

- A:** Refrigerant gas is converted into compressed gas at high temperature and high pressure by a compressor so that gas can be easily cooled and liquefied by a condenser.
- B:** In the condenser, the gas at high temperature and high pressure generated in the compressor is cooled with air and converted into liquid at high temperature and high pressure.
- C:** The electronic expansion valve reduces the pressure of the liquid at high temperature and high pressure and converts it into liquid at low temperature and low pressure by throttling it so that it can be easily evaporated in a cooler.
- D:** In the cooler, liquid at low temperature and low pressure generated in the electronic expansion valve absorbs heat from the oil, evaporates (cools the oil), and is converted into gas at low temperature and low pressure.
- E:** The bypass mechanism controls the cooling capacity at low loads by adjusting the volume of gas at high temperature and high pressure supplied to the cooler.

Piping System Diagram

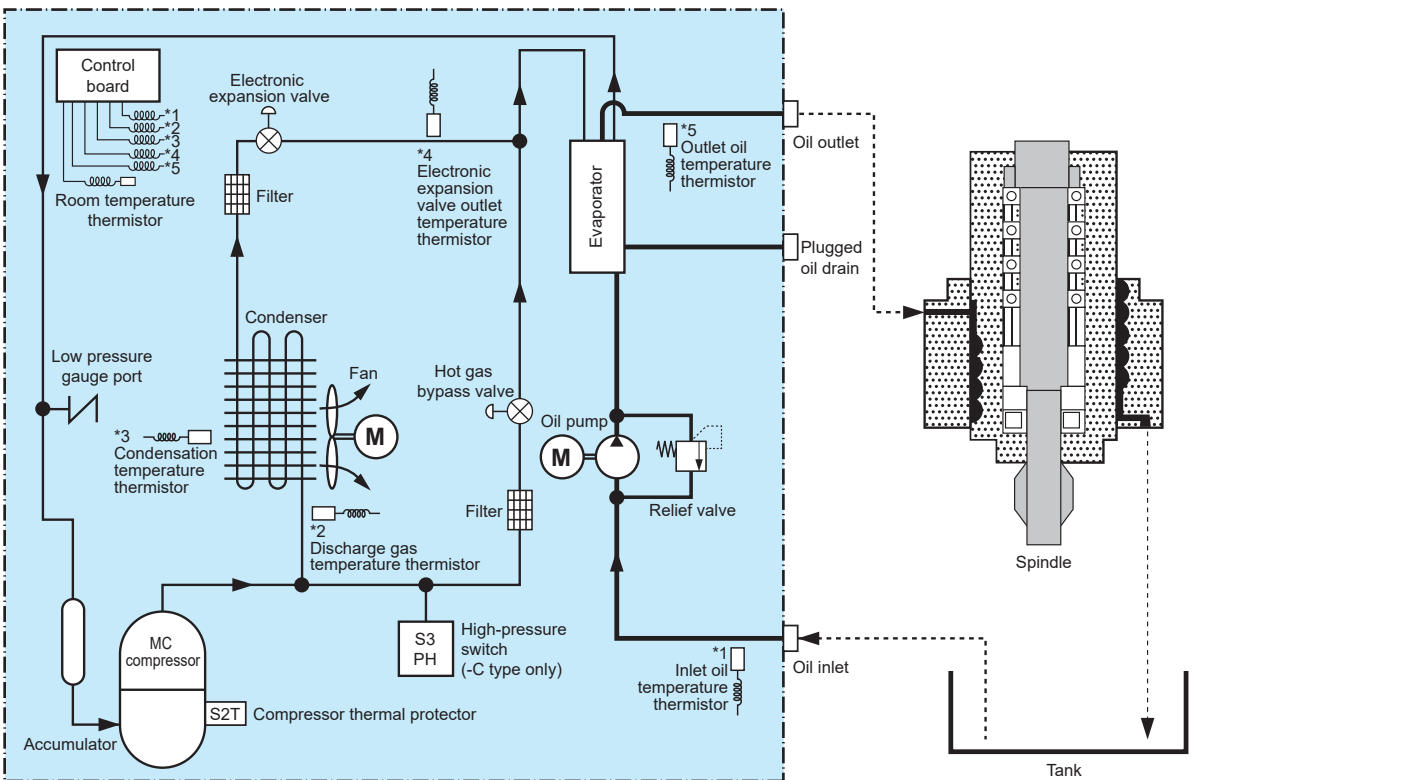

Principle and Overall System Diagram / Piping System Diagram

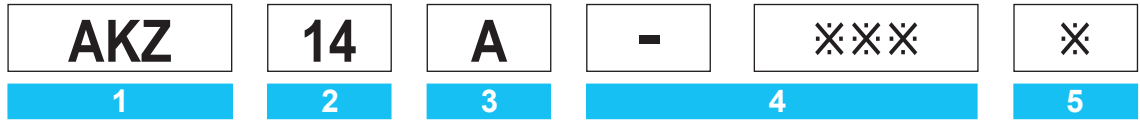

**1 Oil cooling unit identification code**

AKZ: High-accuracy inverter oil cooling unit  
[Circulating type, for cooling oil]

**2 Cooling capacity (kW)**

14: 1.4 kW  
32: 3.2 kW  
43: 4.3 kW  
56 : 5.6 kW  
90 : 9.0 kW

**3 Symbol of series  
(Symbol to represent model change)**

A: 10 series

**4 Symbol of option type/Non-standard number**

Options and their combinations  
(Refer to the following table.)

**Special specifications  
(dual pumps, specified paint colors, etc.)**

-※※※(3-digit number), C※※※(3-digit number), etc.  
Please consult us separately.  
-500 indicates standard specifications  
(380 V/400 V/415 V)

**5 Special specifications  
(specified packing specifications,  
communication options, etc.)**

J: Communications option  
RS485/Modbus protocol

**Options and their combinations**

**■AKZ10 (Circulating type, for cooling oil)**

Option symbol	With breaker	Compliance with CE/UKCA	With heater	With tank	Different voltage (1)	Different voltage (2)	Different voltage (3)	Option symbol	With breaker	Compliance with CE/UKCA	With heater	With tank	Different voltage (1)	Different voltage (2)	Different voltage (3)	
-B	○	-	-	-	-	-	-	B500	○	-	-	-	-	○	-	
-C	-	○	-	-	-	-	-	C500	-	○	-	-	-	-	○	-
-H	-	-	○	-	-	-	-	H500	-	-	○	-	-	-	○	-
-T	-	-	-	○	-	-	-	T500	-	-	-	○	-	-	○	-
-046	-	-	-	-	○	-	-	D500	○	○	-	-	-	-	○	-
-500	-	-	-	-	-	○	-	E500	○	-	○	-	-	-	○	-
-048	○	-	-	-	-	-	○	G500	○	-	-	○	-	-	○	-
-BC	○	○	-	-	-	-	-	K500	-	○	○	-	-	-	○	-
-BH	○	-	○	-	-	-	-	M500	-	○	-	○	-	-	○	-
-BT	○	-	-	○	-	-	-	N500	-	-	○	○	-	-	○	-
-CH	-	○	○	-	-	-	-	P500	○	○	○	-	-	-	○	-
-CT	-	○	-	○	-	-	-	Q500	○	○	-	○	-	-	○	-
-HT	-	-	○	○	-	-	-	R500	○	-	○	○	-	-	○	-
-BCH	○	○	○	-	-	-	-	S500	-	○	○	○	-	-	○	-
-BCT	○	○	-	○	-	-	-	V500	○	○	○	○	-	-	○	-
-BHT	○	-	○	○	-	-	-	-032	○	○	-	-	-	-	-	○
-CHT	-	○	○	○	-	-	-	-033	○	-	○	-	-	-	-	○
-BCHT	○	○	○	○	-	-	-	-034	○	-	-	○	-	-	-	○
-001	○	-	-	-	○	-	-	-038	○	○	○	-	-	-	-	○
-002	-	○	-	-	○	-	-	-039	○	○	-	○	-	-	-	○
-003	-	-	○	-	○	-	-	-040	○	-	○	○	-	-	-	○
-004	-	-	-	○	○	-	-	-044	○	○	○	○	-	-	-	○
-005	○	○	-	-	○	-	-									
-006	○	-	○	-	○	-	-									
-007	○	-	-	○	○	-	-									
-008	-	○	○	-	○	-	-									
-009	-	○	-	○	○	-	-									
-010	-	-	○	○	○	-	-									
-011	○	○	○	-	○	-	-									
-012	○	○	-	○	○	-	-									
-013	○	-	○	○	○	-	-									
-014	-	○	○	○	○	-	-									
-015	○	○	○	○	○	-	-									

**AKZ14A**  
**AKZ32A**  
**AKZ43A**

Oil cooling unit horsepower (HP)	0.5						1.2						1.5						
	AKZ14A						AKZ32A						AKZ43A						
Model name	Standard	-B	-C	-J	-H	-T	Standard	-B	-C	-J	-H	-T	Standard	-B	-C	-J	-H	-T	Different voltage specifications <sup>2</sup>
Cooling capacity (50/60 Hz) <sup>1</sup> kW	1.3/1.4						2.8/3.2						3.8/4.3						
Heater (at 200 V) kW	1						1						1						
Supply power <sup>2</sup>	Three phase AC 200/200-220 V 50/60 Hz						Three phase AC 200/200-220 V 50/60 Hz						Three phase AC 200/200-220 V 50/60 Hz						
Circuit voltage	Main circuit <sup>3</sup>						Three phase AC 200/200-220 V 50/60 Hz						Three phase AC 200/200-220 V 50/60 Hz						
Operating circuit							DC 12/24 V												
Max. power consumption	When cooling	200 V 50 Hz						1.36 kW/5.2 A						1.80 kW/6.6 A					
		200 V 60 Hz						1.43 kW/5.1 A						1.88 kW/6.4 A					
		220 V 60 Hz						1.43 kW/4.9 A						1.88 kW/6.1 A					
Max. current consumption	When heating	200 V 50 Hz						1.51 kW/5.4 A						1.51 kW/5.4 A					
		200 V 60 Hz						1.60 kW/5.4 A						1.60 kW/5.4 A					
		220 V 60 Hz						1.83 kW/5.7 A						1.83 kW/5.7 A					
Transformer capacity	2.6 kVA						2.6 kVA						2.6 kVA						
Exterior color	Ivory white																		
External dimensions (H × W × D) mm	650 × 360 × 440	950 × 360 × 440	810 × 360 × 465	950 × 360 × 440	775 × 360 × 440	1075 × 360 × 440	965 × 360 × 465	1075 × 360 × 440	875 × 360 × 440	1175 × 360 × 440	1065 × 360 × 465	1175 × 360 × 440							
Compressor (Hermetic DC swing type)	Equivalent to 0.4 kW						Equivalent to 0.75 kW						Equivalent to 1.1 kW						
Evaporator	Cross-fin coil type																		
Condenser	Cross-fin coil type																		
Fan Motor	54 W																		
Oil pump	0.4 kW × 4P																		
Oil pump	Discharge volume L/min	12/14.4						24/28.8											
	Open pressure MPa	0.5						0.6											
Temperature control (Selectable)	Standard	Room temperature or machine temperature <sup>4</sup> (Set to "Room temperature: Mode 3" by default)																	
	Object to be controlled	Oil inlet temperature or oil outlet temperature (Set to oil inlet temperature by default)																	
	Synchronization range °C	-9.9 to +9.9 against the reference temperature (Set at 0.0 by default)																	
	Object to be controlled	Oil inlet temperature or oil outlet temperature																	
Fixed type Range °C	5 to 50																		
Refrigerant control	Rotation speed control of compressor by inverter + Opening rate control of electronic expansion valve																		
Refrigerant: Filling amount kg	0.54						0.81						0.83						
R410A (GWP: 2090) <sup>5</sup> Carbon dioxide equivalent tCO <sub>2</sub> eq	1.13						1.70						1.74						
Protection devices	Overcurrent relay (for a pump motor), reverse-phase protection device, restart prevention timer, low room temperature protection thermistor, high oil temperature protection thermistor, low oil temperature protection thermistor, relief valve (for a pump), discharge pipe thermistor, condenser thermistor, refrigerant leakage detector, set of inverter protection devices, high-pressure switch (-C type only), compressor thermal protector, overheat protection temperature switch (-H type only), oil lack protection switch (-H type only), and circuit breaker (-B type only)																		
Room temperature °C	5 to 45																		
Oil inlet temperature °C	5 to 50																		
Operating range	Oil viscosity mm <sup>2</sup> /s	1.4 to 200 (ISO VG2 to 32)																	
External pressure loss	Discharge side	0.5 MPa maximum																	
	Suction side	No lower than -30.7 kPa																	
Acceptable oils	Lubricating oil, mineral oil based hydraulic oil (except for phosphate ester hydraulic oil, water, water-soluble liquid, chemicals, food products, fuel, cutting fluid, grinding fluid, etc.)																		
Connecting tube	Oil inlet	Rc3/4																	
	Oil outlet	Rc3/4	Rc1 1/4	Rc3/4	Rc3/4	Rc1 1/4	Rc3/4	Rc3/4	Rc1 1/4	Rc3/4	Rc3/4	Rc1 1/4	Rc3/4						
	Oil drain	Rc1/4 (Plugged)																	
Noise level (value equivalent to measurement in an anechoic chamber) (Front 1 m, height 1.55 m) dB (A) <sup>6</sup>	62												65						
Permissible transport vibration <sup>7</sup>	Up and down vibration 14.7 m/s <sup>2</sup> × 2.5 hr (7.5 to 100 Hz sweep/five min.)																		
Ingress protection	IP2X <sup>8</sup>																		
Mass kg	57	83	77	93	63	89	83	99	65	95	82	103							
In-machine circuit breaker (rated current) A	- 10						- 10						- 10						
Oil tank (Capacity) L	-						-						20 <sup>9</sup>						
Items prepared by the customer	Earth leakage breaker (Rated current) <sup>10</sup> A						10												

- Note: \*1. The cooling capacity indicates the value at the standard point (inlet oil temperature: 35°C, room temperature: 35°C, oil used: ISO VG32, 1 atm). This unit has about ±5% of product tolerance.  
 \*2. Use a commercial power supply for the power source. The use of an inverter power supply may cause burn damage to the oil cooling unit. The voltage fluctuation range should be within ±10%. If it is more than ±10%, please consult us.  
 \*3. There are three types of different voltage specifications depending on the power source: -046, -048 and -500 units. -048 units deal with the different voltage by featuring a transformer. When equipped with a transformer, the main circuit voltage is the transformer's secondary side voltage of AC 200 V, 50/60 Hz (-046 units and -500 units have no transformer and therefore have the same external dimensions and mass as standard units. Their main circuit voltage is AC 220/230 V, 50/60 Hz for -046 units and AC 380/400/415 V, 50/60 Hz for -500 units.)  
 \*4. The machine temperature synchronization thermistor available as an option is required for this function. (Refer to Page 21 for details.)  
 \*5. The refrigerant is enclosed in a sealed container. The SDS (Safety Data Sheet) for R410A refrigerant is provided with to -C type units.  
 \*6. The rotational speed of the fan motor varies depending on the room temperature to conserve energy. Therefore, it is normal for the noise level to vary accordingly.  
 \*7. The specifications for permissible transport vibration are those of a standard unit.  
 \*8. Electric component section ingress protection: IP54 or equivalent (However, use piping conduits etc. rated at least IP54 at wiring ports.)  
 \*9. The yellow line on the tank oil level gauge shows the highest oil level and the red line the lowest oil level.  
 \*10. The earth leakage breaker is not supplied with this product. Please prepare it yourself.  
 \*11. The maximum power consumption/maximum current consumption of different voltage specifications are shown in the tables below. (For -500 units, refer to pages 7 and 8.)

AKZ14A		AKZ32A		AKZ43A		AKZ56A		AKZ90A	
Supply power	Power/current	Supply power	Power/current	Supply power	Power/current	Supply power	Power/current	Supply power	Power/current
220 V	0.91 kW/ 3.6 A	220 V	1.43 kW/ 4.8 A	220 V	1.88 kW/ 6.0 A	220 V	2.30 kW/ 7.3 A	220 V	4.30 kW/ 13.0 A
230 V	0.91 kW/ 3.4 A	230 V	1.43 kW/ 4.6 A	230 V	1.88 kW/ 5.8 A	230 V	2.30 kW/ 7.0 A	230 V	4.30 kW/ 12.4 A
440 V / 50/60 Hz	0.92 kW/ 1.8 A	440 V / 50/60 Hz	1.45 kW/ 2.4 A	440 V / 50/60 Hz	1.90 kW/ 3.0 A	440 V / 50/60 Hz	2.32 kW/ 3.5 A	440 V / 50/60 Hz	4.33 kW/ 6.2 A
460 V	0.92 kW/ 1.7 A	460 V	1.45 kW/ 2.3 A	460 V	1.90 kW/ 2.9 A	460 V	2.32 kW/ 3.3 A	460 V	4.33 kW/ 5.9 A
480 V	0.92 kW/ 1.7 A	480 V	1.45 kW/ 2.2 A	480 V	1.90 kW/ 2.8 A	480 V	2.32 kW/ 3.2 A	480 V	4.33 kW/ 5.7 A

**AKZ56A  
AKZ90A**

Oil cooling unit horsepower (HP)	2.0						3.0									
	AKZ56A						AKZ90A									
Model name	Standard	-B	-C	-J	-H	-T	Different voltage specifications <sup>3</sup>	Standard	-B	-C	-J	-H	-T	Different voltage specifications <sup>3</sup>		
Cooling capacity (50/60 Hz) <sup>1</sup> kW	5.0/5.6						8.0/9.0									
Heater (at 200 V) kW	2						3									
Supply power <sup>2</sup>	Three phase AC 200/200-220 V 50/60 Hz						*3									
Circuit voltage	Three phase AC 200/200-220 V 50/60 Hz															
	DC 12/24 V															
Max. power consumption	When cooling	200 V 50 Hz	2.22 kW/7.6 A						*11	4.25 kW/13.5 A						
		200 V 60 Hz	2.30 kW/7.5 A							4.30 kW/13.4 A						
		220 V 60 Hz	2.30 kW/7.2 A							4.30 kW/12.9 A						
Max. current consumption	When heating	200 V 50 Hz	2.59 kW/9.3 A						3.64 kW/12.4 A							
		200 V 60 Hz	2.68 kW/9.0 A						3.73 kW/12.2 A							
		220 V 60 Hz	3.11 kW/9.7 A						4.37 kW/13.2 A							
Transformer capacity	—						4.0 kVA						6.0 kVA			
Exterior color	Ivory white															
External dimensions (H × W × D) mm	1110 × 470 × 500	1410 × 470 × 560	1375 × 470 × 580	1360 × 470 × 590	1220 × 560 × 620	1520 × 560 × 680	1485 × 560 × 700	1470 × 560 × 695								
Compressor (Hermetic DC swing type)	Equivalent to 1.5 kW						Equivalent to 2.2 kW									
Evaporator	Braze plate type															
Condenser	Cross-fin coil type															
Fan Motor	100 W															
Oil pump	0.7 kW × 4P															
Discharge volume L/min	30/36															
Open pressure MPa	0.6															
Temperature control (Selectable)	Synchronization type	Standard	Room temperature or machine temperature <sup>4</sup> (Set to "Room temperature: Mode 3" by default)													
		Object to be controlled	Oil inlet temperature or oil outlet temperature (Set to oil inlet temperature by default)													
	Fixed type	Synchronization range °C	-9.9 to +9.9 against the reference temperature (Set at 0.0 by default)													
		Object to be controlled	Oil inlet temperature or oil outlet temperature													
Range °C	5 to 50															
Refrigerant control	Rotation speed control of compressor by inverter + Opening rate control of electronic expansion valve															
Refrigerant: R410A (GWP: 2090) <sup>5</sup>	Filling amount kg	1.02						1.37								
	Carbon dioxide equivalent tCO <sub>2</sub> eq	2.14						2.87								
Protection devices	Overcurrent relay (for a pump motor), reverse-phase protection device, restart prevention timer, low room temperature protection thermistor, high oil temperature protection thermistor, low oil temperature protection thermistor, relief valve (for a pump), discharge pipe thermistor, condenser thermistor, refrigerant leakage detector, set of inverter protection devices, high-pressure switch (-C type only), compressor thermal protector, overheat protection temperature switch (-H type only), oil lack protection switch (-H type only), and circuit breaker (-B type only)															
Operating range	Room temperature °C	5 to 45														
	Oil inlet temperature °C	5 to 50														
	Oil viscosity mm <sup>2</sup> /s	1.4 to 200 (ISO VG2 to 32)														
External pressure loss	Discharge side	0.5 MPa maximum														
	Suction side	No lower than -30.7 kPa														
Acceptable oils	Lubricating oil, mineral oil based hydraulic oil (except for phosphate ester hydraulic oil, water, water-soluble liquid, chemicals, food products, fuel, cutting fluid, grinding fluid, etc.)															
Connecting tube	Oil inlet	Rc1 1/4			Rc1	Rc1 1/4	Rc1 1/4			Rc1	Rc1 1/4					
	Oil outlet	Rc1 1/4														
	Oil drain	Rc1/4 (Plugged)														
Noise level (value equivalent to measurement in an anechoic chamber) (Front 1 m, height 1.55 m) dB (A) <sup>6</sup>	65						67									
Permissible transport vibration <sup>7</sup>	Up and down vibration 14.7 m/s <sup>2</sup> × 2.5 hr (7.5 to 100 Hz sweep/five min.)															
Ingress protection	IP2X <sup>8</sup>															
Mass kg	86			120	119	149	104			145	139	182				
In-machine circuit breaker (rated current) A	-	15	-						-	20	-					
Oil tank (Capacity) L	-						50 <sup>9</sup>						-			
Items prepared by the customer	Earth leakage breaker (Rated current) <sup>10</sup> A						15						20			

Refer to Page 5 for explanatory notes.

**Operating range**

- Note: 1. The "⊙" symbol indicates the standard point.  
 2. Be sure to use the unit within the range of use specified in  .  
 (Use outside this range may cause unit failure.)

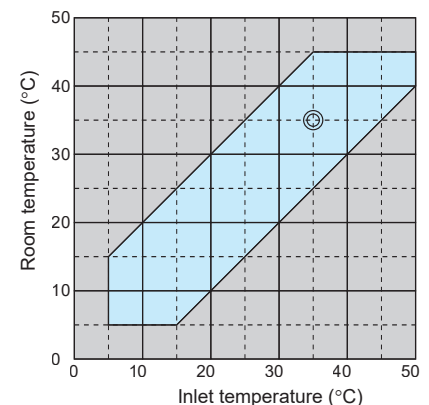

**AKZ14A-500**  
**AKZ32A-500**  
**AKZ43A-500**

Oil cooling unit horsepower (HP)	0.5					1.2					1.5										
	AKZ14A-500					AKZ32A-500					AKZ43A-500										
Model name	Standard	B	C	H	T	Standard	B	C	H	T	Standard	B	C	H	T						
Cooling capacity (50/60 Hz) <sup>1</sup> kW				1.3/1.4					2.8/3.2					3.8/4.3							
Heater (at 400 V) kW		-		1	-		-		1	-		-		1	-						
Supply power <sup>2</sup>	Three phase AC 380/400/415 V 50/60 Hz																				
Circuit voltage	Main circuit																				
	Operating circuit																				
Max. power consumption Max. current consumption	When cooling	380 V 50/60 Hz					1.01 kW/2.3 A					1.59 kW/3.1 A					1.99 kW/3.6 A				
		400 V 50/60 Hz					1.02 kW/2.2 A					1.60 kW/3.0 A					1.99 kW/3.5 A				
		415 V 50/60 Hz					1.03 kW/2.2 A					1.60 kW/2.9 A					2.00 kW/3.4 A				
	When heating	380 V 50/60 Hz					1.70 kW/2.7 A					1.75 kW/2.8 A					1.75 kW/2.8 A				
		400 V 50/60 Hz					1.80 kW/2.7 A					1.85 kW/2.8 A					1.85 kW/2.8 A				
		415 V 50/60 Hz					1.91 kW/2.8 A					1.96 kW/2.9 A					1.96 kW/2.9 A				
Exterior color	Ivory white																				
External dimension (H × W × D) mm	650 × 360 × 440	950 × 360 × 440	810 × 360 × 535	775 × 360 × 440	1075 × 360 × 440	965 × 360 × 535	875 × 360 × 440	1175 × 360 × 440	1065 × 360 × 535												
Compressor (Hermetic DC swing type)	Equivalent to 0.4 kW					Equivalent to 0.75 kW					Equivalent to 1.1 kW										
Evaporator	Cross-fin-coil type																				
Condenser	Cross-fin-coil type																				
Propeller fan	Motor																				
	φ240, 54 W					φ300, 54 W					0.4 kW × 4 P										
Oil pump	Motor																				
	Discharge volume L/min					12/14.4					24/28.8										
Open pressure MPa																					
Temperature control (Selectable)	Synchronization type	Standard																			
		Room temperature or machine temperature <sup>3</sup> (Set to "Room temperature: Mode 3" by default)																			
	Fixed type	Object to be controlled																			
		Oil inlet temperature or oil outlet temperature (Set to oil inlet temperature by default)																			
Synchronization range °C																					
-9.9 to +9.9 against the reference temperature (Set at 0.0 by default)																					
Object to be controlled																					
Oil inlet temperature or oil outlet temperature																					
Range °C																					
5 to 50																					
Refrigerant control	Rotation speed control of compressor by inverter + Opening rate control of electric expansion valve																				
Refrigerant: R410A (GWP: 2090) <sup>4</sup>	Filling amount Kg																				
	0.54					0.81					0.83										
Carbon dioxide equivalent tCO <sub>2</sub> eq																					
1.13					1.70					1.74											
Protection devices	Overcurrent relay (for a pump motor), reverse-phase protection device, restart prevention timer, low room temperature protection thermistor, high oil temperature protection thermistor, low oil temperature protection thermistor, relief valve (for a pump), discharge pipe thermistor, condenser thermistor, refrigerant leakage detector, set of inverter protection devices, high-pressure switch (C type only), compressor thermal protector, overheat protection temperature switch (H type only), oil lack protection switch (H type only), and circuit breaker (B type only)																				
Room temperature °C																					
5 to 45																					
Oil inlet temperature °C																					
5 to 50																					
Operating range	Oil viscosity mm <sup>2</sup> /s																				
	1.4 to 200 (ISO VG2 to 32)																				
	External pressure loss																				
Discharge side																					
0.5 MPa maximum																					
Suction side																					
No lower than -30.7 kPa																					
Acceptable oils	Lubricating oil, mineral oil based hydraulic oil (except for phosphate ester hydraulic oil, water, water-soluble liquid, chemicals, food products, fuel, cutting fluid, grinding fluid, etc.)																				
Connecting tube	Oil inlet																				
	Rc3/4					Rc1 1/4					Rc3/4										
	Oil outlet																				
Rc3/4																					
Oil drain																					
Rc1/4 (Plugged)																					
Noise level (value equivalent to measurement in an anechoic chamber) (Front 1 m, height 1.55 m) dB (A) <sup>5</sup>	62					65															
Permissible transport vibration <sup>6</sup>	Up and down vibration 14.7 m/s <sup>2</sup> × 2.5 hr (7.5 to 100 Hz sweep/five min.)																				
Ingress protection	IP2X <sup>7</sup>																				
Mass kg	57	87	77	63	93	83	67	97	87												
Internal molded-case circuit breaker (Rated current) A	-	10	-	-	10	-	-	10	-												
Oil tank (Capacity) L		-	15 <sup>8</sup>		-	20 <sup>8</sup>		-	20 <sup>8</sup>												
Items prepared by the customer	Earth leakage breaker (Rated current) <sup>9</sup> A																				
	10																				

- Note: \*1. The cooling capacity indicates the value at the standard point (inlet oil temperature: 35°C, room temperature: 35°C, oil used: ISO VG32, 1 atm). This unit has about ±5% of product tolerance.  
 \*2. Use a commercial power supply for the power source. The use of an inverter power supply may cause burn damage to the oil cooling unit.  
 \*3. The machine temperature synchronization thermistor available as an option is required for this function. (Refer to Page 21 for details.)  
 \*4. The refrigerant is enclosed in a sealed container. The SDS (Safety Data Sheet) for R410A refrigerant is provided with to C type units.  
 \*5. The rotational speed of the fan varies depending on the room temperature to conserve energy. Therefore, it is normal for the noise level to vary accordingly.  
 \*6. The specifications for permissible transport vibration are those of a standard unit.  
 \*7. Electric component box ingress protection: IP54 or equivalent (However, use piping conduits etc. rated at least IP54 at wiring ports.)  
 \*8. The yellow line on the tank oil level gauge shows the highest oil level and the red line the lowest oil level.  
 \*9. The earth leakage breaker is not supplied with this product. Please prepare it yourself.



**AKZ56A-500**  
**AKZ90A-500**

Oil cooling unit horsepower (HP)		2.0					3.0						
		AKZ56A-500					AKZ90A-500						
Model name		Standard	B	C	H	T	Standard	B	C	H	T		
Cooling capacity (50/60 Hz) <sup>1</sup> kW					5.0/5.6					8.0/9.0			
Heater (at 400 V) kW			-		2	-		-		3	-		
Supply power <sup>2</sup>		Three phase AC 380/400/415 V 50/60 Hz											
Circuit voltage	Main circuit	Three phase AC 380/400/415 V 50/60 Hz											
	Operating circuit	DC 12/24 V											
Max. power consumption	When cooling	380 V 50/60 Hz		2.49 kW/4.6 A			400 V 50/60 Hz		2.54 kW/4.6 A			4.39 kW/8.4 A	
		415 V 50/60 Hz		2.54 kW/4.5 A			415 V 50/60 Hz		4.38 kW/8.1 A				
		415 V 50/60 Hz		2.80 kW/4.8 A			415 V 50/60 Hz		3.98 kW/6.4 A				
Max. current consumption	When heating	380 V 50/60 Hz		2.44 kW/4.3 A			400 V 50/60 Hz		3.43 kW/5.8 A			-	
		400 V 50/60 Hz		2.64 kW/4.6 A			400 V 50/60 Hz		3.74 kW/6.2 A			-	
		415 V 50/60 Hz		2.80 kW/4.8 A			415 V 50/60 Hz		3.98 kW/6.4 A			-	
Exterior color		Ivory white											
External dimension (H × W × D) mm		1110 × 470 × 500		1410 × 470 × 560	1375 × 470 × 580		1220 × 560 × 620		1520 × 560 × 680	1485 × 560 × 700			
Compressor (Hermetic DC swing type)		Equivalent to 1.5 kW					Equivalent to 2.2 kW						
Evaporator		Brazed plate type											
Condenser		Cross-fin-coil type											
Propeller fan	Motor	φ400, 100 W					φ455, 100 W						
	Motor	0.7 kW × 4 P											
Oil pump	Discharge volume L/min	30/36											
	Open pressure MPa	0.6											
Temperature control (Selectable)	Synchronization type	Standard		Room temperature or machine temperature <sup>3</sup> (Set to "Room temperature: Mode 3" by default)									
		Object to be controlled		Oil inlet temperature or oil outlet temperature (Set to oil inlet temperature by default)									
	Fixed type	Synchronization range °C		-9.9 to +9.9 against the reference temperature (Set at 0.0 by default)									
		Object to be controlled		Oil inlet temperature or oil outlet temperature									
Range °C		5 to 50											
Refrigerant control		Rotation speed control of compressor by inverter + Opening rate control of electric expansion valve											
Refrigerant: R410A (GWP: 2090) <sup>4</sup>	Filling amount Kg	1.02					1.37						
	Carbon dioxide equivalent tCO <sub>2</sub> eq	2.14					2.87						
Protection devices		Overcurrent relay (for a pump motor), reverse-phase protection device, restart prevention timer, low room temperature protection thermistor, high oil temperature protection thermistor, low oil temperature protection thermistor, relief valve (for a pump), discharge pipe thermistor, condenser thermistor, refrigerant leakage detector, set of inverter protection devices, high-pressure switch (C type only), compressor thermal protector, overheat protection temperature switch (H type only), oil lock protection switch (H type only), and circuit breaker (B type only)											
Operating range	Room temperature °C		5 to 45										
	Oil inlet temperature °C		5 to 50										
	Oil viscosity mm <sup>2</sup> /s		1.4 to 200 (ISO VG2 to 32)										
	External pressure loss	Discharge side	0.5 MPa maximum										
Suction side		No lower than -30.7 kPa											
Acceptable oils		Lubricating oil, mineral oil based hydraulic oil (except for phosphate ester hydraulic oil, water, water-soluble liquid, chemicals, food products, fuel, cutting fluid, grinding fluid, etc.)											
Connecting tube	Oil inlet	Rc11/4			Rc1		Rc11/4			Rc1			
	Oil outlet	Rc11/4											
	Oil drain	Rc1/4 (Plugged)											
Noise level (value equivalent to measurement in an anechoic chamber) (Front 1 m, height 1.55 m) dB (A) <sup>5</sup>		65					67						
Permissible transport vibration <sup>6</sup>		Up and down vibration 14.7 m/s <sup>2</sup> × 2.5 hr (7.5 to 100 Hz sweep/five min.)											
Ingress protection		IP2X <sup>7</sup>											
Mass kg		86		120	119		104		145	139			
Internal molded-case circuit breaker (Rated current) A		-	15		-		-	20		-			
Oil tank (Capacity) L		-					50 <sup>8</sup>		-			70 <sup>8</sup>	
Items prepared by the customer	Earth leakage breaker (Rated current) <sup>9</sup> A	15					20						

Refer to Page 7 for explanatory notes.

**Operating range**

- Note: 1. The mark "⊙" shows the standard point.  
2. Be sure to use the unit within the range of use specified in .  
(Use outside this range may cause unit failure.)

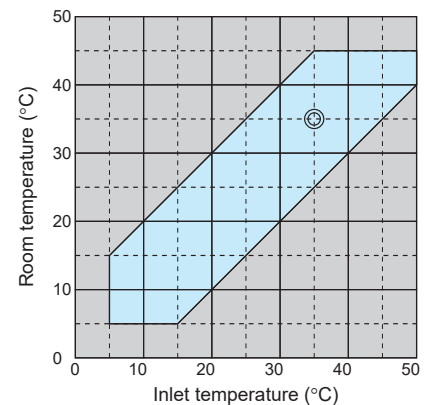

## AKZ14A

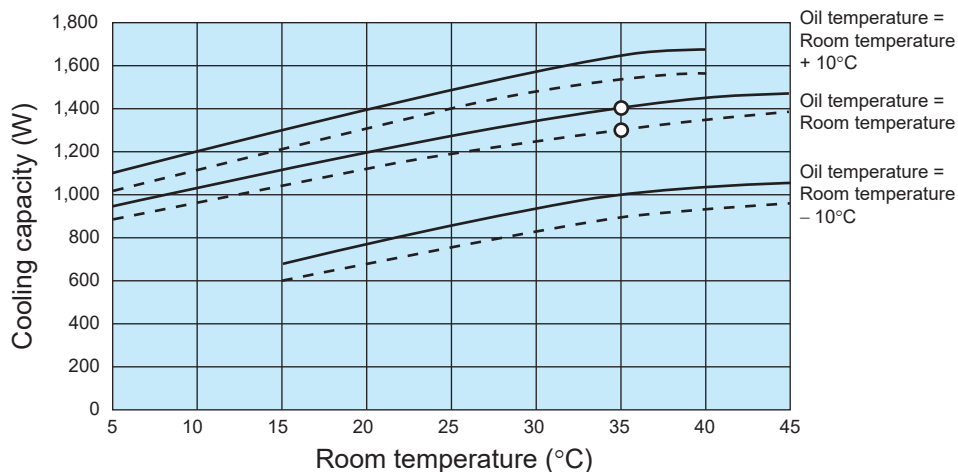

## AKZ32A

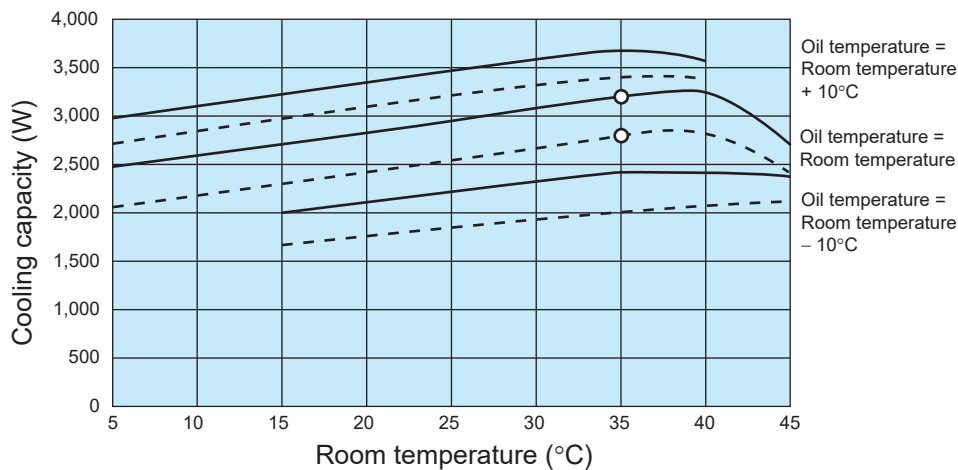

## AKZ43A

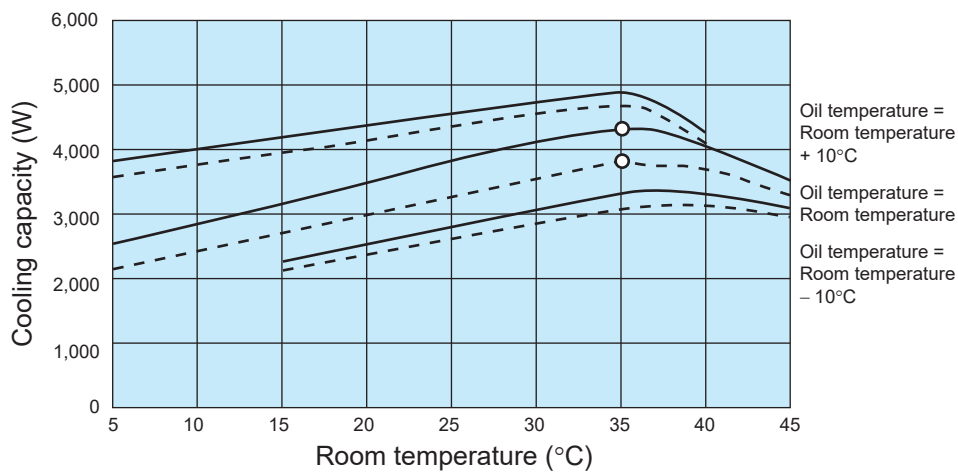

## AKZ56A

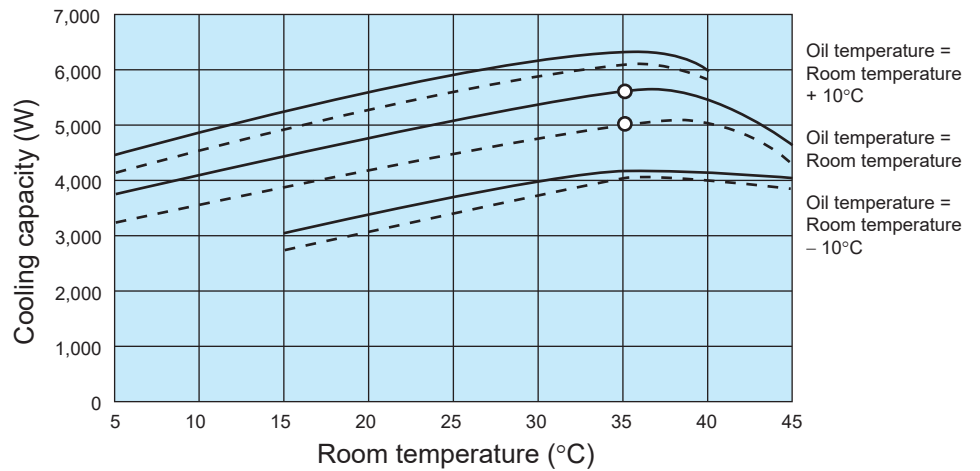

## AKZ90A

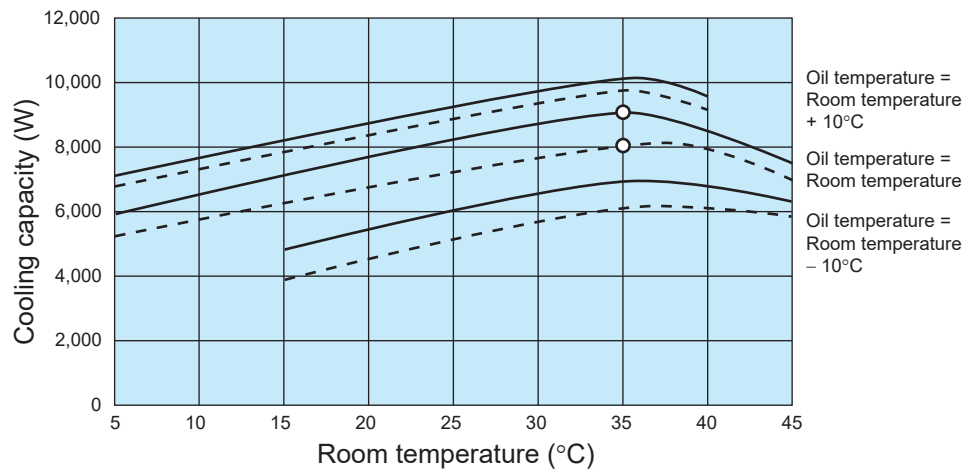

■ Solid line — : When operated at 60 Hz ■ Broken line - - - : When operated at 50 Hz

1. The mark "O" shows the standard point.

(Room temperature: 35°C/Oil inlet temperature: 35°C/Oil used: ISO VG32)

2. The cooling capacity varies depending on conditions such as the room temperature, oil inlet temperature, oil dynamic viscosity and other factors.

**AKZ14A (-B, -C, -046, -500)**

Standard specifications

With breaker

Compliance with CE/UKCA

Transformerless 400 V specifications

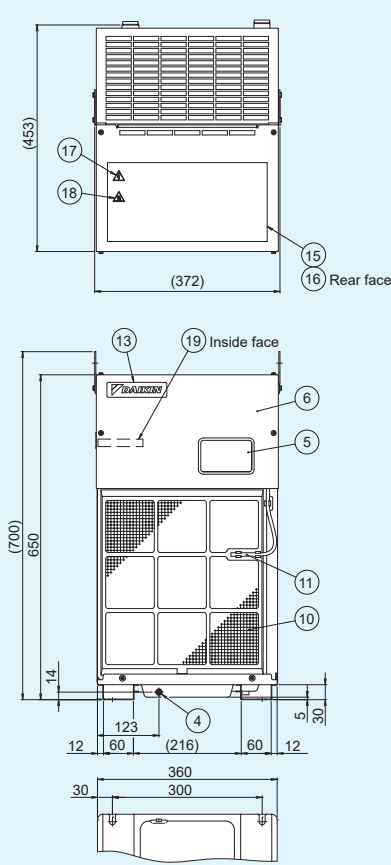

Part No.	Name	Description
1	Oil inlet	Rc3/4
2	Oil outlet	Rc3/4
3	Oil drain	Rc1/4 plugged
4	Oil pan drain	M6 plugged
5	Control panel	
6	Electrical component box cover	
7	Power supply inlet (Right/Left)	φ28 hole
8	Signal line inlet (Right/Left)	φ22 hole
9	Eye plate	φ25 hole

Part No.	Name	Description
10	Air filter	
11	Room temperature thermistor	
12	Unit nameplate	
13	Design nameplate	
14	Instruction nameplate	
15	Overall caution nameplate	
16	Electric wiring diagram nameplate	
17	Battery charge mark nameplate	
18	High temperature caution nameplate	
19	Model nameplate	

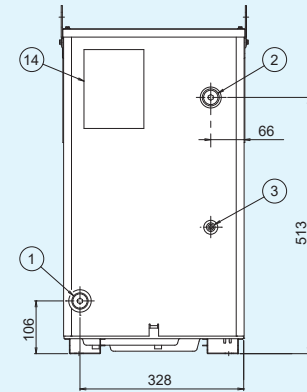
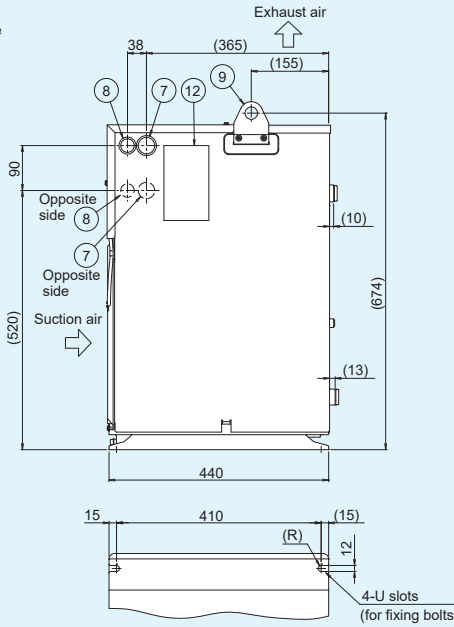

**AKZ14A-H**

With heater

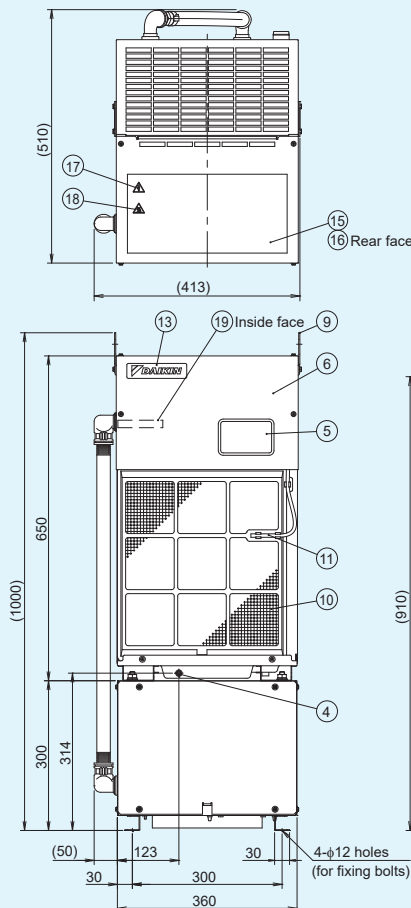

Part No.	Name	Description
1	Oil inlet	Rc3/4
2	Oil outlet	Rc1 1/4
3	Oil drain	Rc1/4 plugged
4	Oil pan drain	M6 plugged
5	Control panel	
6	Electrical component box cover	
7	Power supply inlet	φ28 hole
8	Signal line inlet	φ22 hole
9	Eye plate	φ25 hole
10	Air filter	

Part No.	Name	Description
11	Room temperature thermistor	
12	Unit nameplate	
13	Design nameplate	
14	Instruction nameplate	
15	Overall caution nameplate	
16	Electric wiring diagram nameplate	
17	Battery charge mark nameplate	
18	High temperature caution nameplate	
19	Model nameplate	
20	Heater box	
21	Heater drain	Rc1/4 Plugged

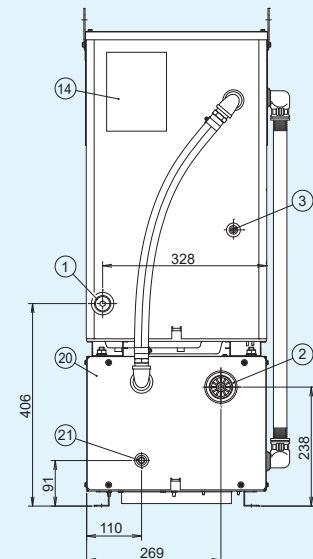
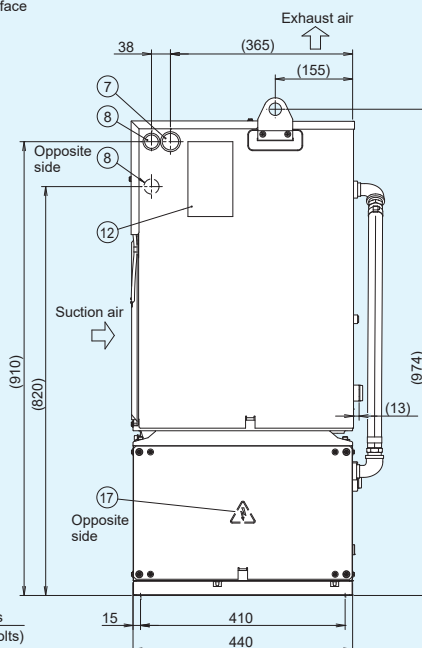

**AKZ14A-T**

**With tank**

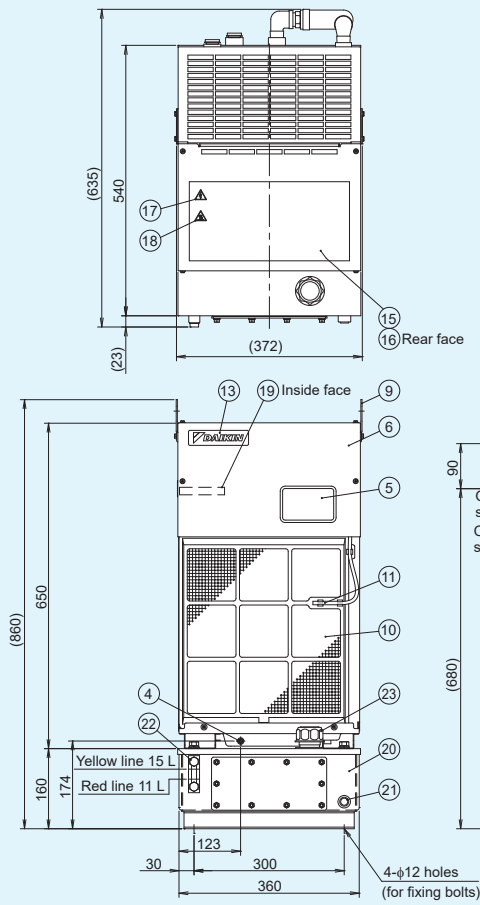

Part No.	Name	Description
1	Oil inlet	Rc3/4
2	Oil outlet	Rc3/4
3	Oil drain	Rc1/4 plugged
4	Oil pan drain	M6 plugged
5	Control panel	
6	Electrical component box cover	
7	Power supply inlet (Right/Left)	φ28 hole
8	Signal line inlet (Right/Left)	φ22 hole
9	Eye plate	φ25 hole
10	Air filter	
11	Room temperature thermistor	

Part No.	Name	Description
12	Unit nameplate	
13	Design nameplate	
14	Instruction nameplate	
15	Overall caution nameplate	
16	Electric wiring diagram nameplate	
17	Battery charge mark nameplate	
18	High temperature caution nameplate	
19	Model nameplate	
20	Oil tank	15 L
21	Tank drain	Rc3/8 plugged
22	Oil level gauge*	
23	Oil hole-cum-air bleeder	

\* The yellow line on the oil level gauge shows the highest oil level and the red line the lowest oil level. (Keep the level between the yellow and red lines during use.)

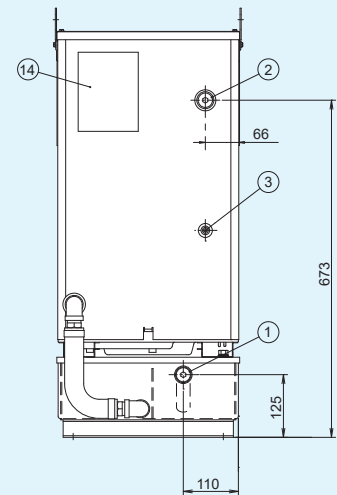
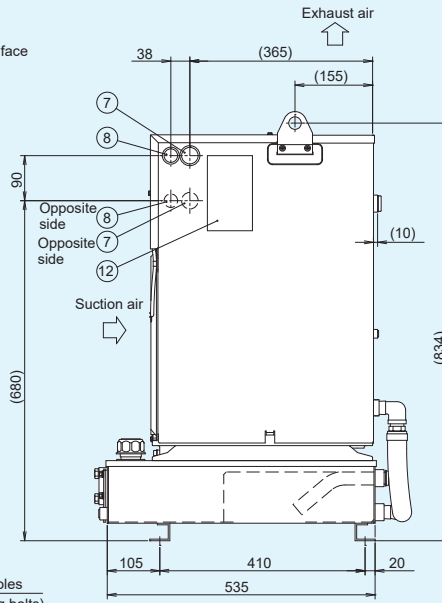

**AKZ14A-048**

**Different voltages (With transformer)**

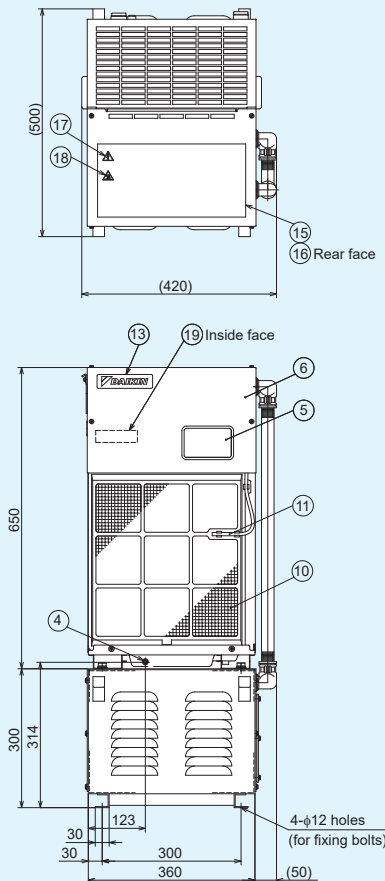

Part No.	Name	Description
1	Oil inlet	Rc3/4
2	Oil outlet	Rc3/4
3	Oil drain	Rc1/4 plugged
4	Oil pan drain	M6 plugged
5	Control panel	
6	Electrical component box cover	
7	Power supply inlet (Right/Left)	φ28 hole
8	Signal line inlet (Right/Left)	φ22 hole
9	Hanger	φ25 hole
10	Air filter	

Part No.	Name	Description
11	Room temperature thermistor	
12	Unit nameplate	
13	Design nameplate	
14	Instruction nameplate	
15	Overall caution nameplate	
16	Electric wiring diagram nameplate	
17	Battery charge mark nameplate	
18	High temperature caution nameplate	
19	Model nameplate	
20	Transformer	
21	Transformer box	

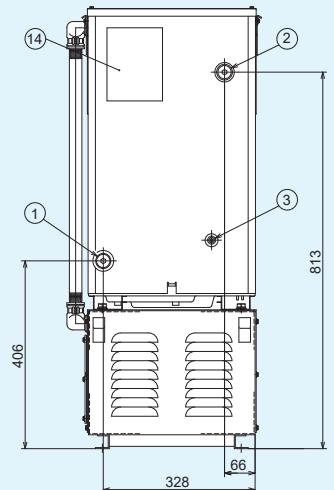
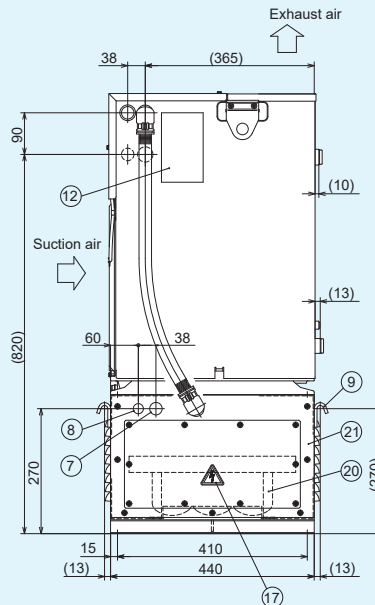

**AKZ32A (-B, -C, -046, -500)**

Standard specifications

With breaker

Compliance with CE/UKCA

Transformerless 400 V specifications

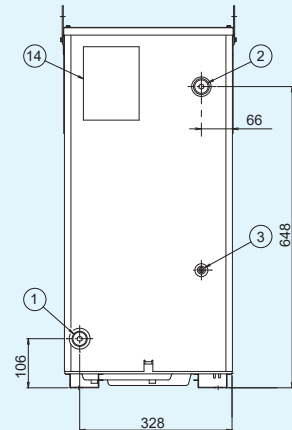
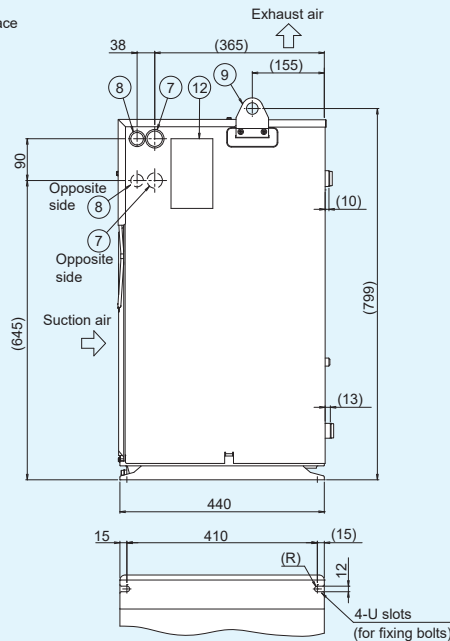
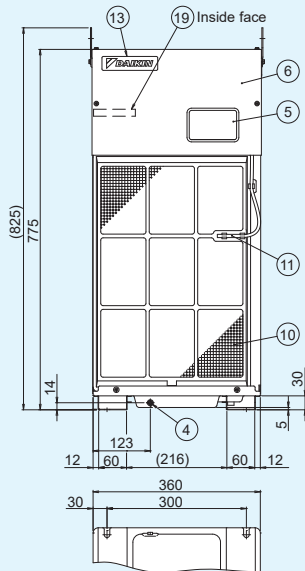
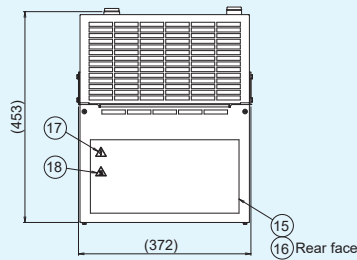

Part No.	Name	Description
1	Oil inlet	Rc3/4
2	Oil outlet	Rc3/4
3	Oil drain	Rc1/4 plugged
4	Oil pan drain	M6 plugged
5	Control panel	
6	Electrical component box cover	
7	Power supply inlet (Right/Left)	φ28 hole
8	Signal line inlet (Right/Left)	φ22 hole
9	Eye plate	φ25 hole

Part No.	Name	Description
10	Air filter	
11	Room temperature thermistor	
12	Unit nameplate	
13	Design nameplate	
14	Instruction nameplate	
15	Overall caution nameplate	
16	Electric wiring diagram nameplate	
17	Battery charge mark nameplate	
18	High temperature caution nameplate	
19	Model nameplate	

**AKZ32A-H**

With heater

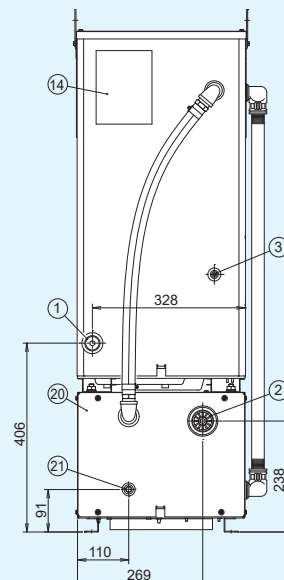
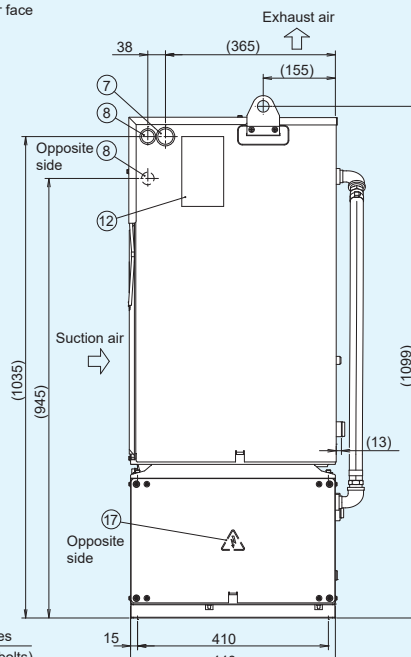
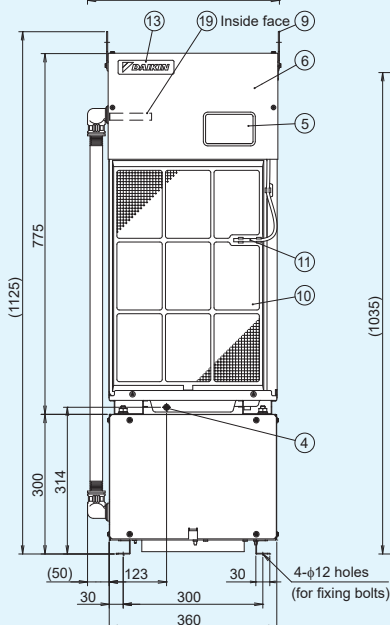
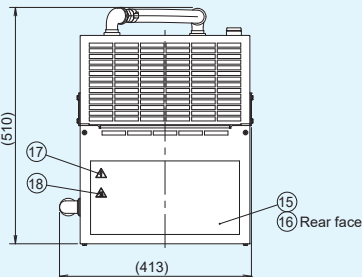

Part No.	Name	Description
1	Oil inlet	Rc3/4
2	Oil outlet	Rc1 1/4
3	Oil drain	Rc1/4 plugged
4	Oil pan drain	M6 plugged
5	Control panel	
6	Electrical component box cover	
7	Power supply inlet	φ28 hole
8	Signal line inlet	φ22 hole
9	Eye plate	φ25 hole
10	Air filter	

Part No.	Name	Description
11	Room temperature thermistor	
12	Unit nameplate	
13	Design nameplate	
14	Instruction nameplate	
15	Overall caution nameplate	
16	Electric wiring diagram nameplate	
17	Battery charge mark nameplate	
18	High temperature caution nameplate	
19	Model nameplate	
20	Heater box	
21	Heater drain	Rc1/4 Plugged

**AKZ32A-T**

With tank

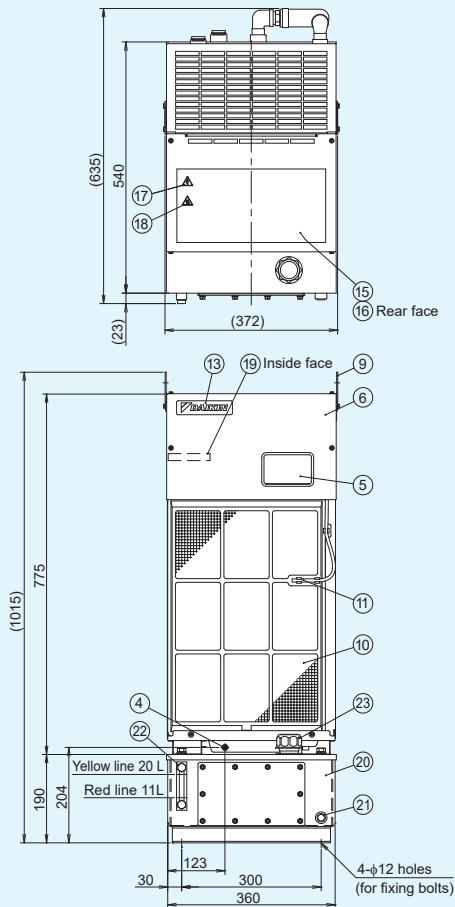

Part No.	Name	Description
1	Oil inlet	Rc3/4
2	Oil outlet	Rc3/4
3	Oil drain	Rc1/4 Plugged
4	Oil pan drain	M6 plugged
5	Control panel	
6	Electrical component box cover	
7	Power supply inlet (Right/Left)	φ28 hole
8	Signal line inlet (Right/Left)	φ22 hole
9	Eye plate	φ25 hole
10	Air filter	
11	Room temperature thermistor	

Part No.	Name	Description
12	Unit nameplate	
13	Design nameplate	
14	Instruction nameplate	
15	Overall caution nameplate	
16	Electric wiring diagram nameplate	
17	Battery charge mark nameplate	
18	High temperature caution nameplate	
19	Model nameplate	
20	Oil tank	20 L
21	Tank drain	Rc3/8 plugged
22	Oil level gauge*	
23	Oil hole-cum-air bleeder	

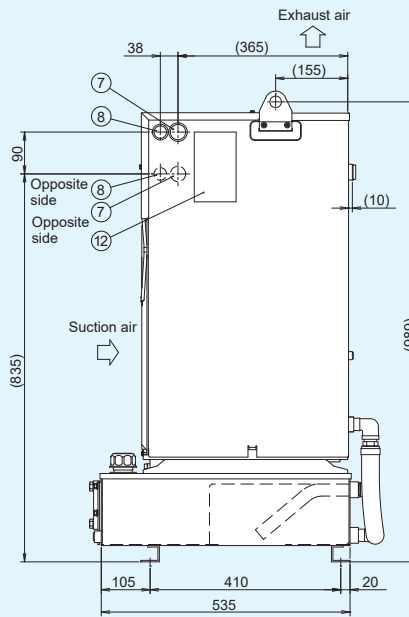

\* The yellow line on the oil level gauge shows the highest oil level and the red line the lowest oil level. (Keep the level between the yellow and red lines during use.)

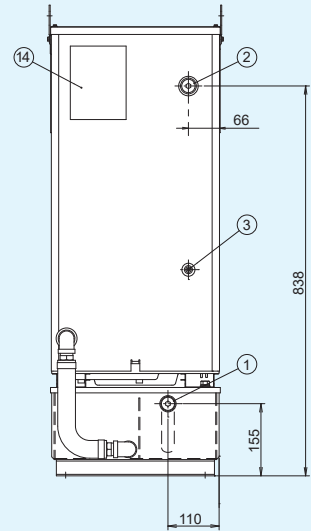

**AKZ32A-048**

Different voltages (With transformer)

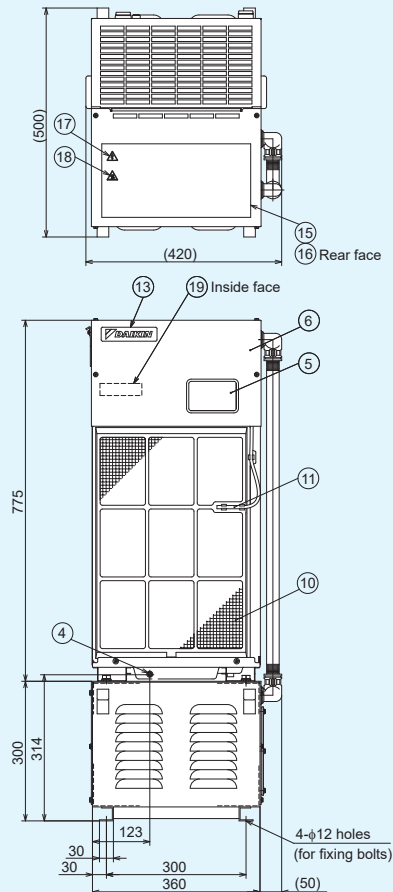

Part No.	Name	Description
1	Oil inlet	Rc3/4
2	Oil outlet	Rc3/4
3	Oil drain	Rc1/4 plugged
4	Oil pan drain	M6 plugged
5	Control panel	
6	Electrical component box cover	
7	Power supply inlet (Right/Left)	φ28 hole
8	Signal line inlet (Right/Left)	φ22 hole
9	Hanger	φ25 hole
10	Air filter	

Part No.	Name	Description
11	Room temperature thermistor	
12	Unit nameplate	
13	Design nameplate	
14	Instruction nameplate	
15	Overall caution nameplate	
16	Electric wiring diagram nameplate	
17	Battery charge mark nameplate	
18	High temperature caution nameplate	
19	Model nameplate	
20	Transformer	
21	Transformer box	

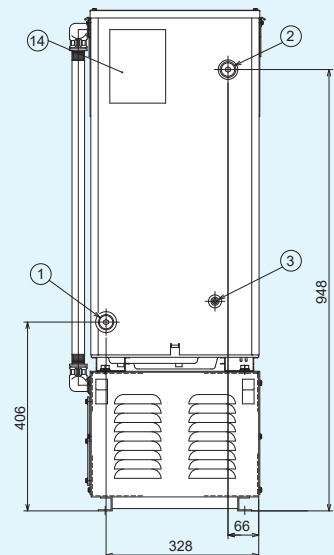
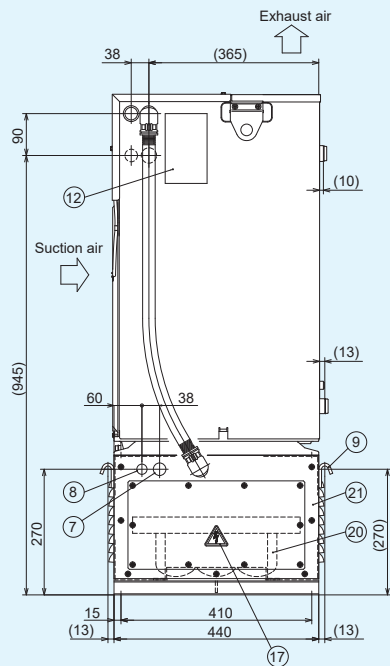

**AKZ43A (-B, -C, -046, -500)**

Standard specifications

With breaker

Compliance with CE/UKCA

Transformerless 400 V specifications

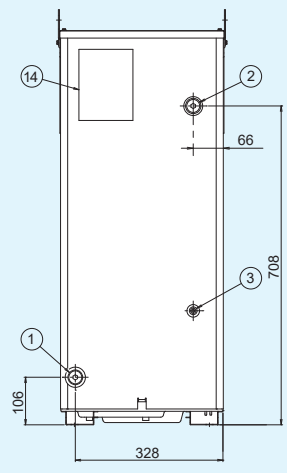
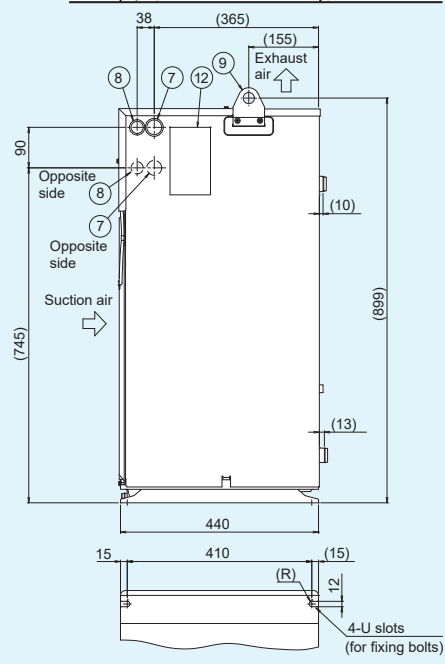
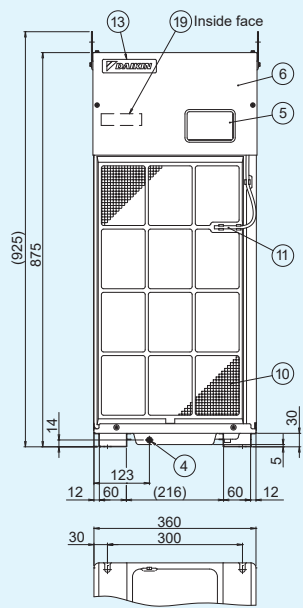
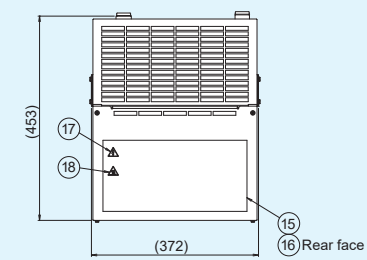

Part No.	Name	Description
1	Oil inlet	Rc3/4
2	Oil outlet	Rc3/4
3	Oil drain	Rc1/4 Plugged
4	Oil pan drain	M6 plugged
5	Control panel	
6	Electrical component box cover	
7	Power supply inlet (Right/Left)	φ28 hole
8	Signal line inlet (Right/Left)	φ22 hole
9	Eye plate	φ25 hole

Part No.	Name	Description
10	Air filter	
11	Room temperature thermistor	
12	Unit nameplate	
13	Design nameplate	
14	Instruction nameplate	
15	Overall caution nameplate	
16	Electric wiring diagram nameplate	
17	Battery charge mark nameplate	
18	High temperature caution nameplate	
19	Model nameplate	

**AKZ43A-H**

With heater

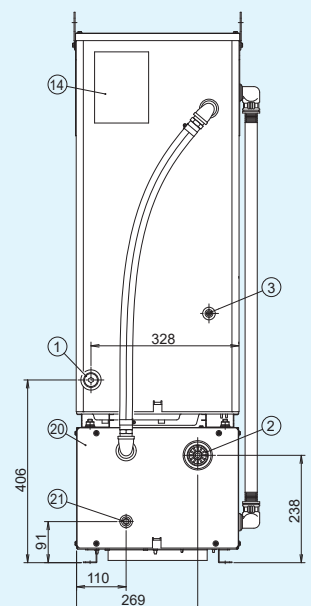
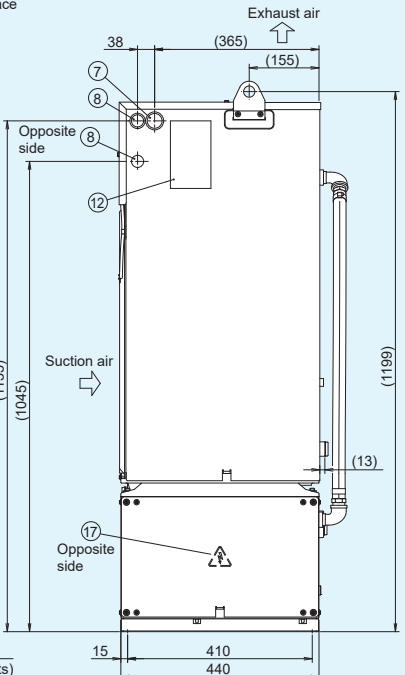
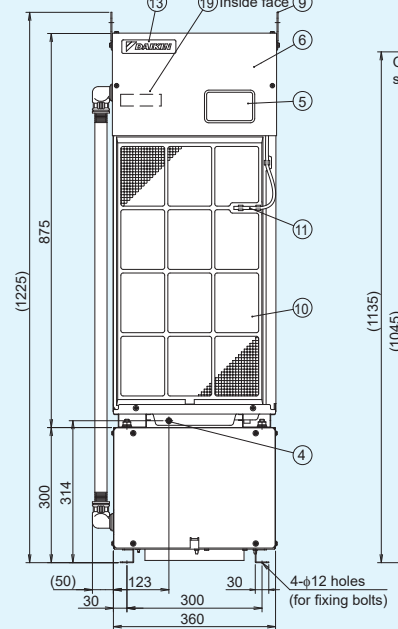
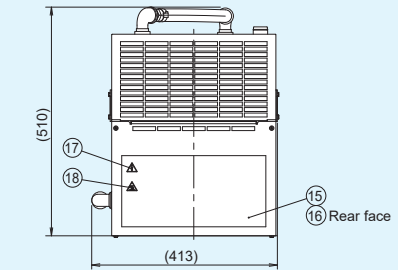

Part No.	Name	Description
1	Oil inlet	Rc3/4
2	Oil outlet	Rc1 1/4
3	Oil drain	Rc1/4 plugged
4	Oil pan drain	M6 plugged
5	Control panel	
6	Electrical component box cover	
7	Power supply inlet	φ28 hole
8	Signal line inlet	φ22 hole
9	Eye plate	φ25 hole
10	Air filter	

Part No.	Name	Description
11	Room temperature thermistor	
12	Unit nameplate	
13	Design nameplate	
14	Instruction nameplate	
15	Overall caution nameplate	
16	Electric wiring diagram nameplate	
17	Battery charge mark nameplate	
18	High temperature caution nameplate	
19	Model nameplate	
20	Heater box	
21	Heater drain	Rc1/4 plugged



**AKZ43A-T**

**With tank**

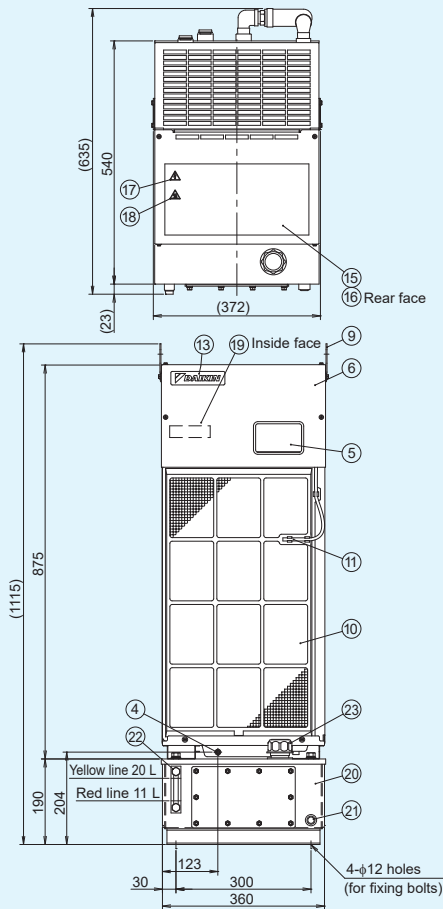

Part No.	Name	Description
1	Oil inlet	Rc3/4
2	Oil outlet	Rc3/4
3	Oil drain	Rc1/4 plugged
4	Oil pan drain	M6 plugged
5	Control panel	
6	Electrical component box cover	
7	Power supply inlet (Right/Left)	φ28 hole
8	Signal line inlet (Right/Left)	φ22 hole
9	Eye plate	φ25 hole
10	Air filter	
11	Room temperature thermistor	

Part No.	Name	Description
12	Unit nameplate	
13	Design nameplate	
14	Instruction nameplate	
15	Overall caution nameplate	
16	Electric wiring diagram nameplate	
17	Battery charge mark nameplate	
18	High temperature caution nameplate	
19	Model nameplate	
20	Oil tank	20 L
21	Tank drain	Rc3/8 plugged
22	Oil level gauge*	
23	Oil hole-cum-air bleeder	

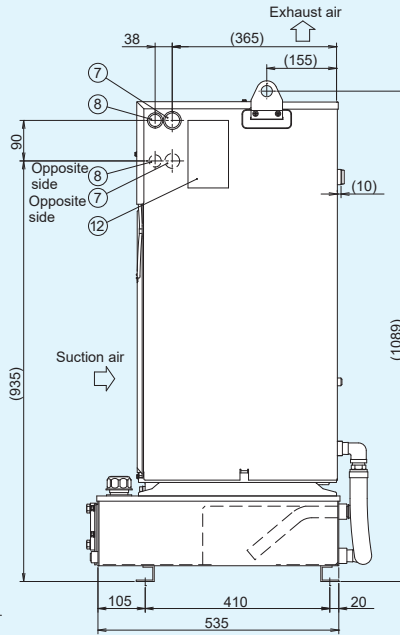

\* The yellow line on the oil level gauge shows the highest oil level and the red line the lowest oil level. (Keep the level between the yellow and red lines during use.)

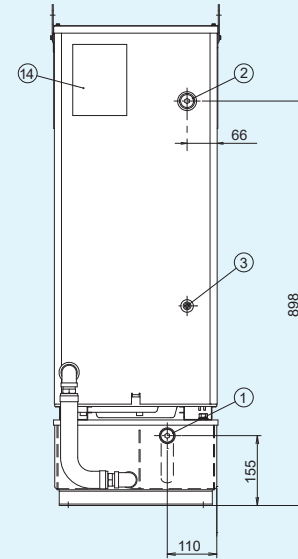

**AKZ43A-048**

**Different voltages (With transformer)**

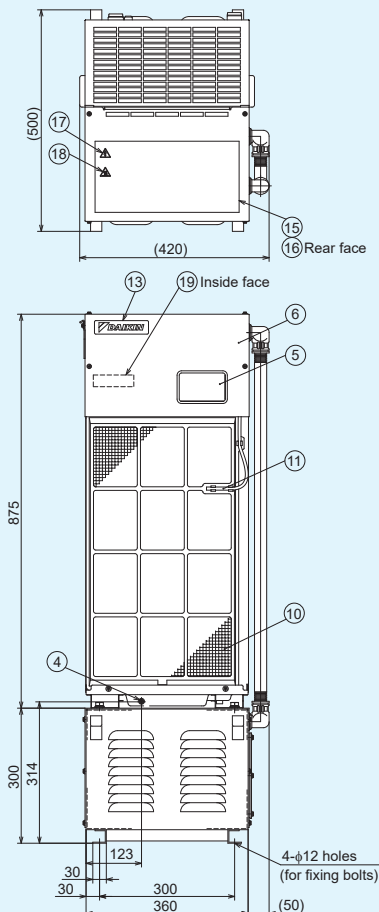

Part No.	Name	Description
1	Oil inlet	Rc3/4
2	Oil outlet	Rc3/4
3	Oil drain	Rc1/4 plugged
4	Oil pan drain	M6 plugged
5	Control panel	
6	Electrical component box cover	
7	Power supply inlet (Right/Left)	φ28 hole
8	Signal line inlet (Right/Left)	φ22 hole
9	Hanger	φ25 hole
10	Air filter	

Part No.	Name	Description
11	Room temperature thermistor	
12	Unit nameplate	
13	Design nameplate	
14	Instruction nameplate	
15	Overall caution nameplate	
16	Electric wiring diagram nameplate	
17	Battery charge mark nameplate	
18	High temperature caution nameplate	
19	Model nameplate	
20	Transformer	
21	Transformer box	

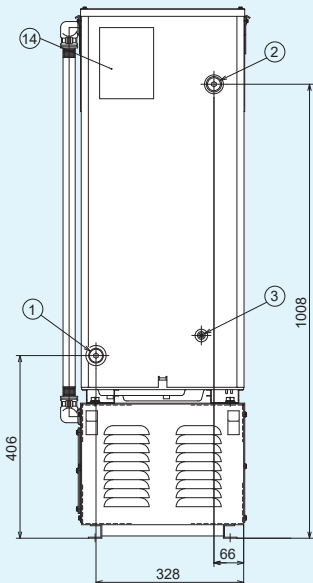
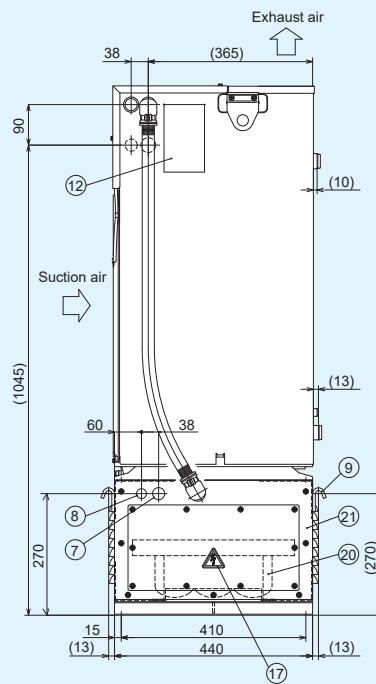

**AKZ56A (-B, -C, -046, -500)**

Standard specifications

With breaker

Compliance with CE/UKCA

Transformerless 400 V specifications

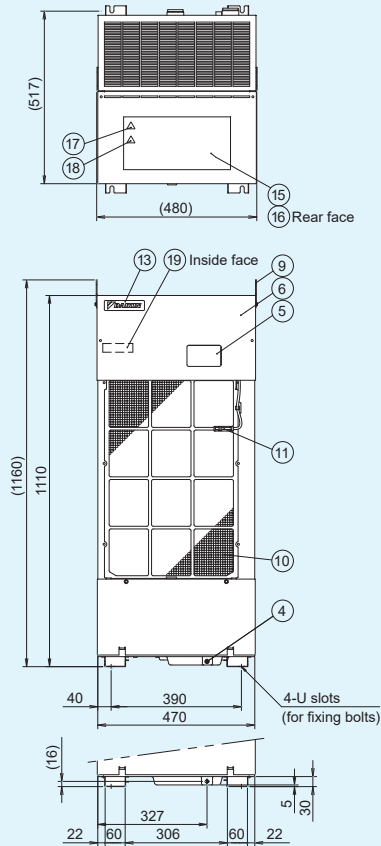

Part No.	Name	Description
1	Oil inlet	Rc1 1/4
2	Oil outlet	Rc1 1/4
3	Oil drain	Rc1/4 plugged
4	Oil pan drain	M6 plugged
5	Control panel	
6	Electrical component box cover	
7	Power supply inlet (Right/Left)	φ28 hole
8	Signal line inlet (Right/Left)	φ22 hole
9	Eye plate	φ25 hole

Part No.	Name	Description
10	Air filter	
11	Room temperature thermistor	
12	Unit nameplate	
13	Design nameplate	
14	Instruction nameplate	
15	Overall caution nameplate	
16	Electric wiring diagram nameplate	
17	Battery charge mark nameplate	
18	High temperature caution nameplate	
19	Model nameplate	

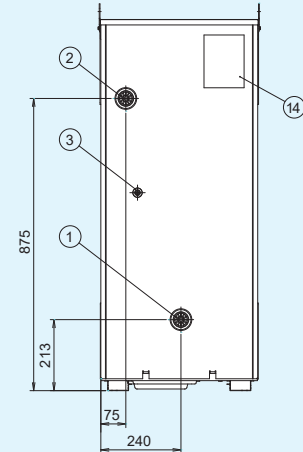
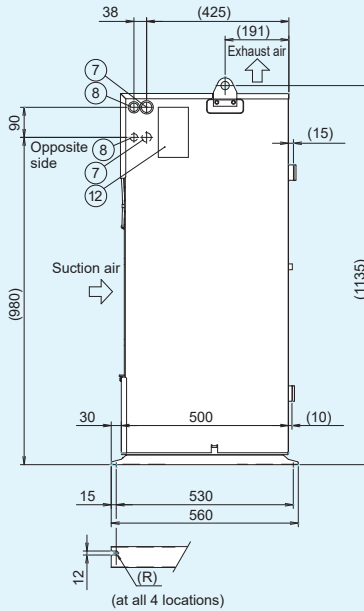

**AKZ56A-H**

With heater

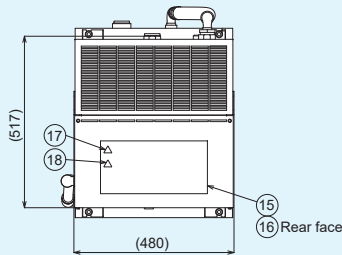

Part No.	Name	Description
1	Oil inlet	Rc1 1/4
2	Oil outlet	Rc1 1/4
3	Oil drain	Rc1/4 plugged
4	Oil pan drain	M6 plugged
5	Control panel	
6	Electrical component box cover	
7	Power supply inlet	φ28 hole
8	Signal line inlet (Right/Left)	φ22 hole
9	Eye plate	φ25 hole
10	Air filter	

Part No.	Name	Description
11	Room temperature thermistor	
12	Unit nameplate	
13	Design nameplate	
14	Instruction nameplate	
15	Overall caution nameplate	
16	Electric wiring diagram nameplate	
17	Battery charge mark nameplate	
18	High temperature caution nameplate	
19	Model nameplate	
20	Heater box	
21	Heater drain	Rc1/4 Plugged

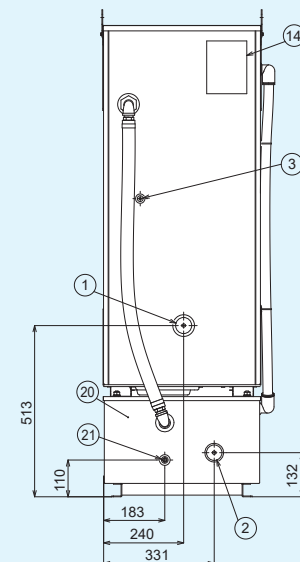
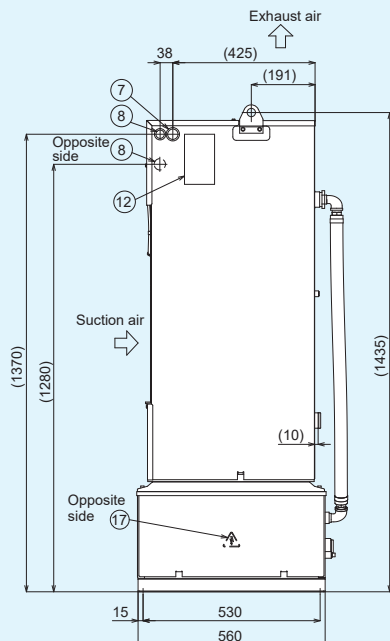
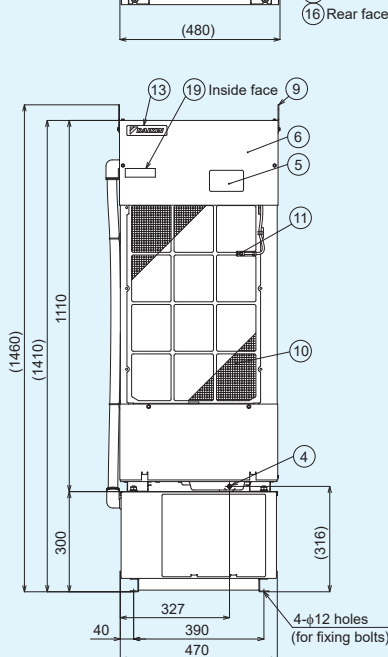

**AKZ56A-T**

**With tank**

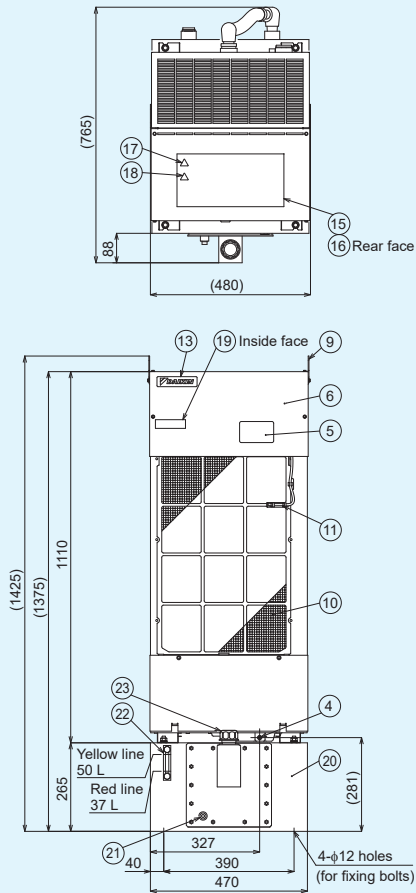

Part No.	Name	Description
1	Oil inlet	Rc1
2	Oil outlet	Rc1 1/4
3	Oil drain	Rc1/4 plugged
4	Oil pan drain	M6 plugged
5	Control panel	
6	Electrical component box cover	
7	Power supply inlet (Right/Left)	φ28 hole
8	Signal line inlet (Right/Left)	φ22 hole
9	Eye plate	φ25 hole
10	Air filter	
11	Room temperature thermistor	

Part No.	Name	Description
12	Unit nameplate	
13	Design nameplate	
14	Instruction nameplate	
15	Overall caution nameplate	
16	Electric wiring diagram nameplate	
17	Battery charge mark nameplate	
18	High temperature caution nameplate	
19	Model nameplate	
20	Oil tank	50 L
21	Tank drain	Rc3/8 plugged
22	Oil level gauge*	
23	Oil hole-cum-air bleeder	

\* The yellow line on the oil level gauge shows the highest oil level and the red line the lowest oil level. (Keep the level between the yellow and red lines during use.)

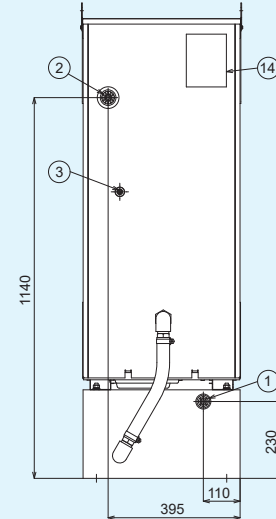
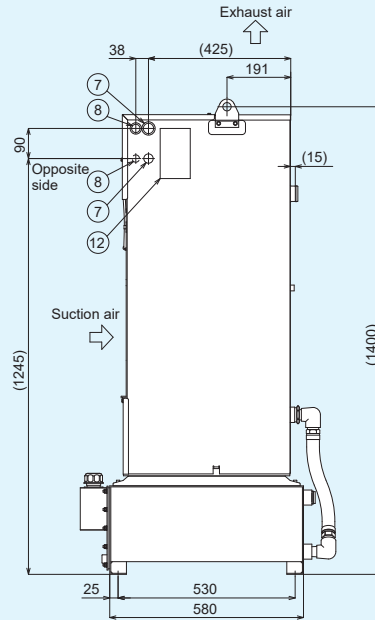

**AKZ56A-048**

**Different voltages (With transformer)**

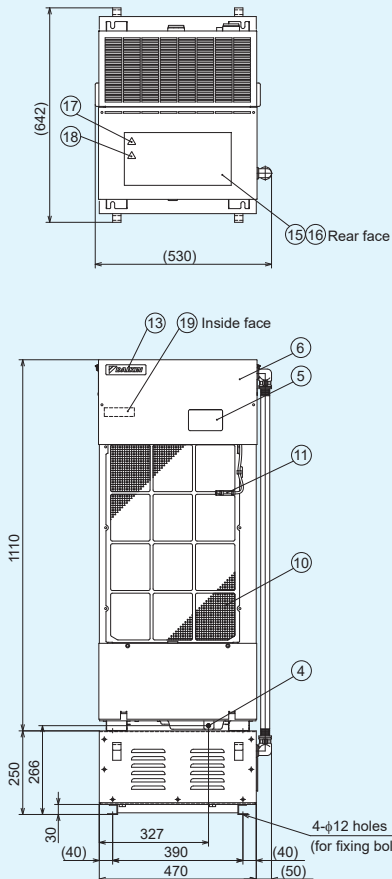

Part No.	Name	Description
1	Oil inlet	Rc3/4
2	Oil outlet	Rc3/4
3	Oil drain	Rc1/4 plugged
4	Oil pan drain	M6 plugged
5	Control panel	
6	Electrical component box cover	
7	Power supply inlet (Right/Left)	φ28 hole
8	Signal line inlet (Right/Left)	φ22 hole
9	Hanger	φ25 hole
10	Air filter	

Part No.	Name	Description
11	Room temperature thermistor	
12	Unit nameplate	
13	Design nameplate	
14	Instruction nameplate	
15	Overall caution nameplate	
16	Electric wiring diagram nameplate	
17	Battery charge mark nameplate	
18	High temperature caution nameplate	
19	Model nameplate	
20	Transformer	
21	Transformer box	

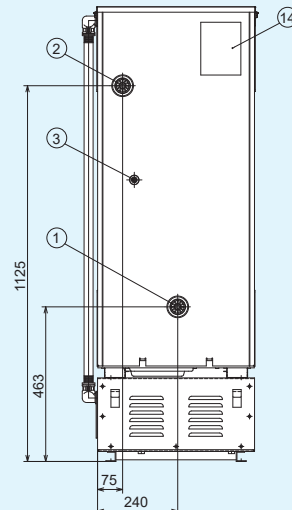
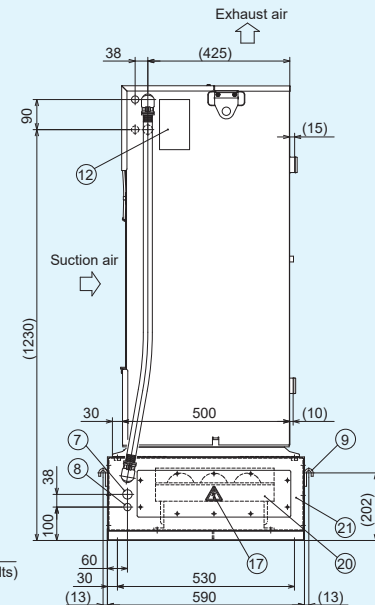

**AKZ90A (-B, -C, -046, -500)**

Standard specifications

With breaker

Compliance with CE/UKCA

Transformerless 400 V specifications

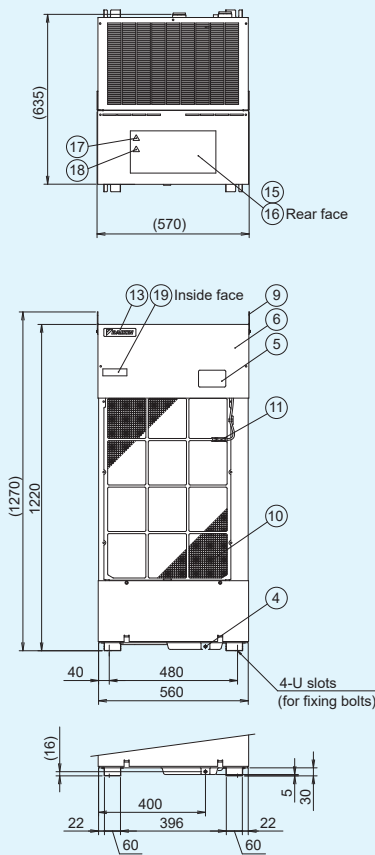

Part No.	Name	Description
1	Oil inlet	Rc1 1/4
2	Oil outlet	Rc1 1/4
3	Oil drain	Rc1/4 plugged
4	Oil pan drain	M6 plugged
5	Control panel	
6	Electrical component box cover	
7	Power supply inlet (Right/Left)	φ28 hole
8	Signal line inlet (Right/Left)	φ22 hole
9	Eye plate	φ25 hole

Part No.	Name	Description
10	Air filter	
11	Room temperature thermistor	
12	Unit nameplate	
13	Design nameplate	
14	Instruction nameplate	
15	Overall caution nameplate	
16	Electric wiring diagram nameplate	
17	Battery charge mark nameplate	
18	High temperature caution nameplate	
19	Model nameplate	

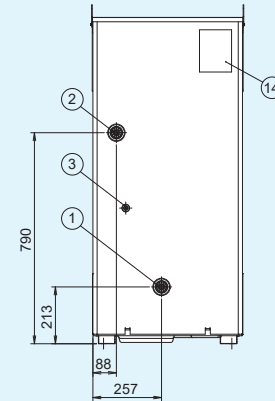
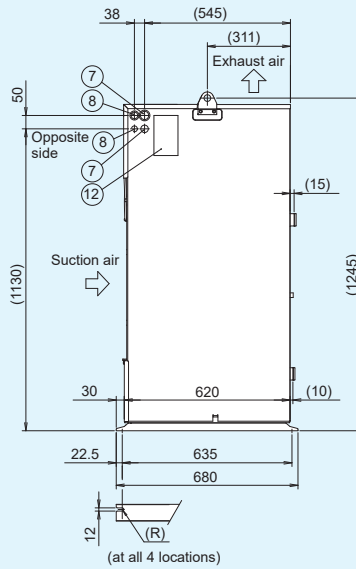

**AKZ90A-H**

With heater

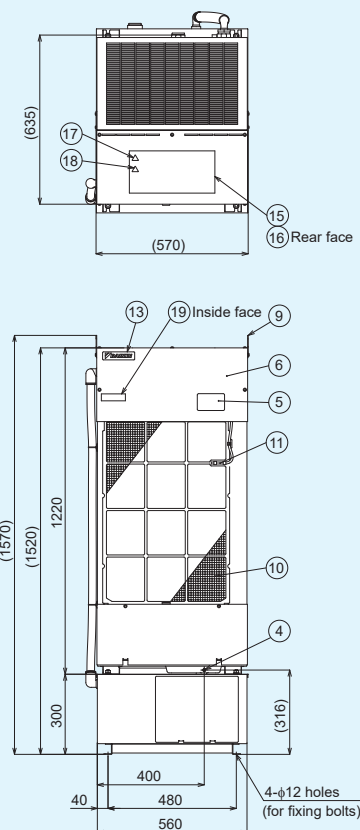

Part No.	Name	Description
1	Oil inlet	Rc1 1/4
2	Oil outlet	Rc1 1/4
3	Oil drain	Rc1/4 plugged
4	Oil pan drain	M6 plugged
5	Control panel	
6	Electrical component box cover	
7	Power supply inlet	φ28 hole
8	Signal line inlet	φ22 hole
9	Eye plate	φ25 hole
10	Air filter	

Part No.	Name	Description
11	Room temperature thermistor	
12	Unit nameplate	
13	Design nameplate	
14	Instruction nameplate	
15	Overall caution nameplate	
16	Electric wiring diagram nameplate	
17	Battery charge mark nameplate	
18	High temperature caution nameplate	
19	Model nameplate	
20	Heater box	
21	Heater drain	Rc1/4 Plugged

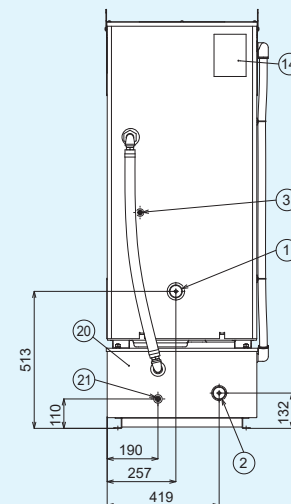
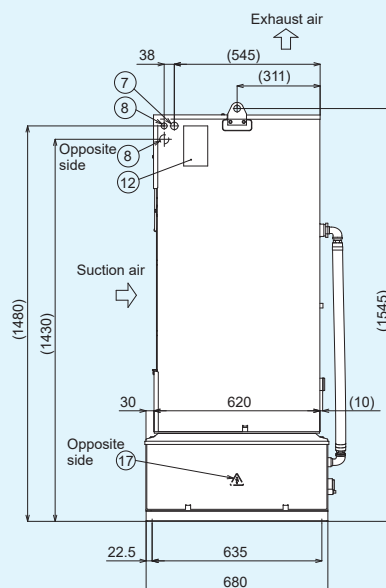

**AKZ90A-T**

With tank

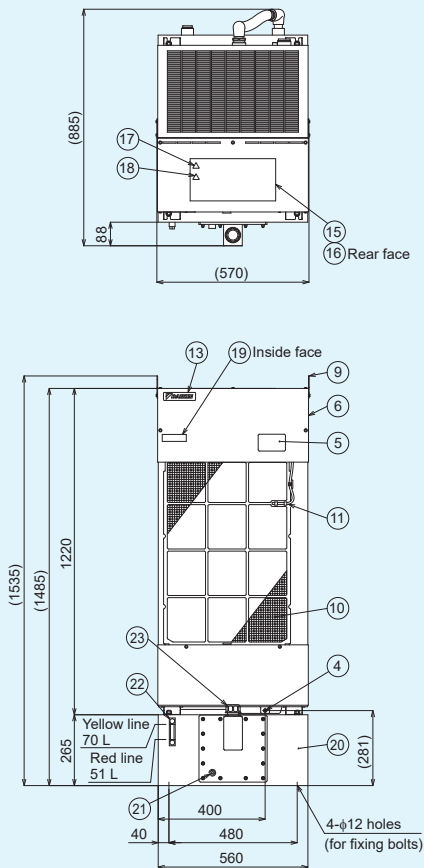

Part No.	Name	Description
1	Oil inlet	Rc1
2	Oil outlet	Rc1 1/4
3	Oil drain	Rc1/4 plugged
4	Oil pan drain	M6 plugged
5	Control panel	
6	Electrical component box cover	
7	Power supply inlet (Right/Left)	φ28 hole
8	Signal line inlet (Right/Left)	φ22 hole
9	Eye plate	φ25 hole
10	Air filter	
11	Room temperature thermistor	

Part No.	Name	Description
12	Unit nameplate	
13	Design nameplate	
14	Instruction nameplate	
15	Overall caution nameplate	
16	Electric wiring diagram nameplate	
17	Battery charge mark nameplate	
18	High temperature caution nameplate	
19	Model nameplate	
20	Oil tank	70 L
21	Tank drain	Rc3/8 plugged
22	Oil level gauge*	
23	Oil hole-cum-air bleeder	

\* The yellow line on the oil level gauge shows the highest oil level and the red line the lowest oil level. (Keep the level between the yellow and red lines during use.)

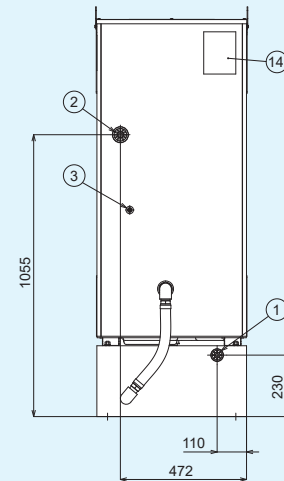
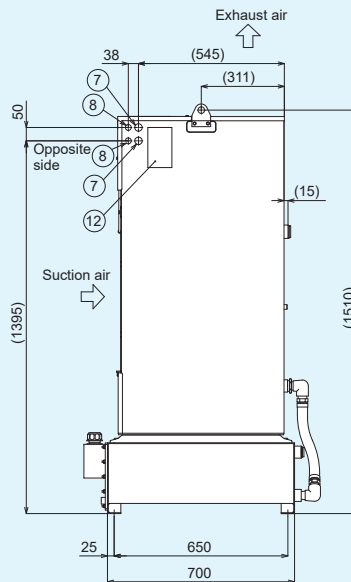

**AKZ90A-048**

Different voltages (With transformer)

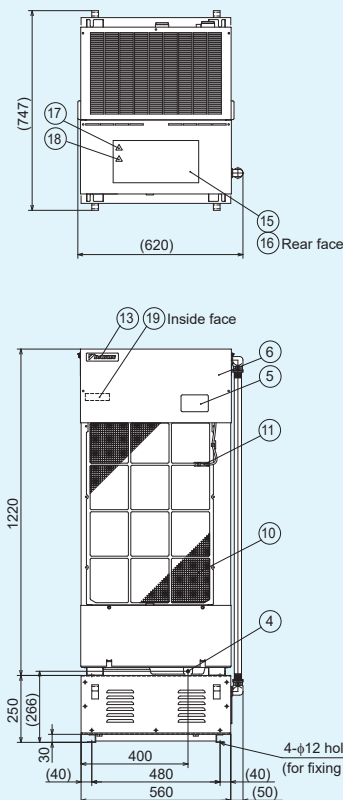

Part No.	Name	Description
1	Oil inlet	Rc3/4
2	Oil outlet	Rc3/4
3	Oil drain	Rc1/4 plugged
4	Oil pan drain	M6 plugged
5	Control panel	
6	Electrical component box cover	
7	Power supply inlet (Right/Left)	φ28 hole
8	Signal line inlet (Right/Left)	φ22 hole
9	Hanger	φ25 hole
10	Air filter	

Part No.	Name	Description
11	Room temperature thermistor	
12	Unit nameplate	
13	Design nameplate	
14	Instruction nameplate	
15	Overall caution nameplate	
16	Electric wiring diagram nameplate	
17	Battery charge mark nameplate	
18	High temperature caution nameplate	
19	Model nameplate	
20	Transformer	
21	Transformer box	

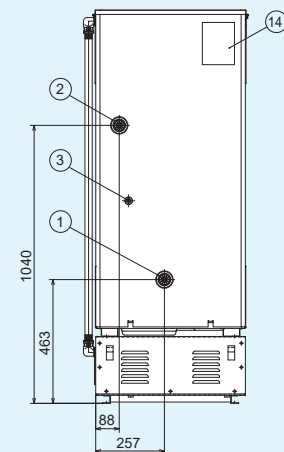
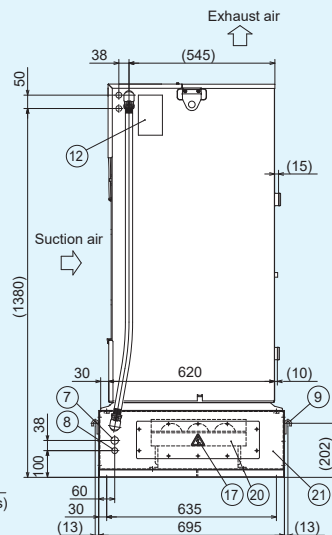

## Thermistor (Compatible with All Types of Oil Cooling Unit AKZ※※A (10 Series))

### Thermistor models and applications

When this optional part is installed in the oil piping of the machine, the thermistor detects the oil or water temperature for the unit's operation.

Name	Model	Length of lead wire L (m)	Figure	Application (To be installed by you)
Thermistor for machine body synchronization	AKZ-OP-K5	5 m		For machine temperature synchronization control (implanted in the machine body)
	AKZ-OP-K10	10 m		
	AKZ-OP-K15	15 m		
Thermistor for machine body synchronization	AKZ-OP-A5	5 m		For machine temperature synchronization control (attached to the surface of the machine body)
	AKZ-OP-A10	10 m		
Thermistor for oil temperature control	AKZ-OP-Y5	5 m		For return oil temperature control (Installed in the oil pipe or water pipe of the machine)
	AKZ-OP-Y10	10 m		

Thermistor characteristics: Resistance value ... R25 (Resistance value at 25°C) = 20 kΩ, Tolerance: ±3%

### Instruction for installation and connection

**For AKZ-OP-K**

Rc 1/8 (To be made on the machine side)  
Pilot hole φ8, 20 or more in depth

Connect to oil cooling unit X2M terminal box Nos. 30 and 31.

Fill the hollow portion with silicone grease.  
Recommended grease: Heat dissipating grease No. KS609 made by Shin-Etsu Chemical Co., Ltd.  
Heat dissipating grease No. KS609 made by Shin-Etsu Chemical Co., Ltd.

**For AKZ-OP-A**

Please prepare the band and mounting screws by yourself.

Connect to Oil Cooling Unit x 2M Terminal box Nos. 30 and 31.

Keep this part in close contact with the machine body and cover the part with putty.

**For AKZ-OP-Y**

Rc 1/8 Screw seat  
Oil piping

Connect to oil cooling unit control board connector CN11.  
(Replace this part with the oil outlet thermistor and operate in the oil outlet temperature control mode Nos. 1, 5 and 6.)

### Installation positions of the thermistor for machine synchronization and thermistor for oil temperature control

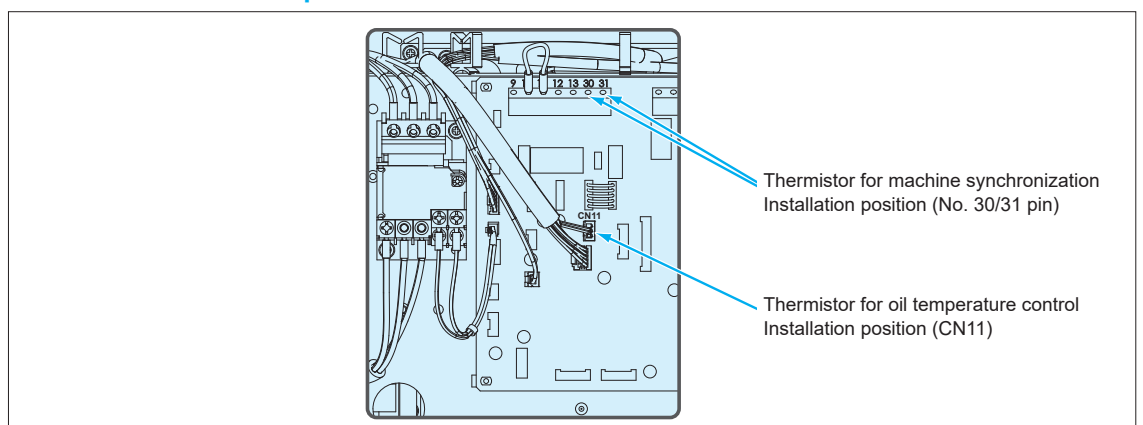

## Option Board for Communication (Serial Communication/ Parallel Communication) Compatible with 10 Series Oil Cooling Units

The following can be achieved by mounting this option board on the Oil Cooling Unit's control board and communicating with the machine.

1. Changing the operation mode and the operation setting from the machine
2. Reading various data such as the alarm code and temperature-related data (machine temperature, room temperature, inlet oil temperature, outlet oil temperature, inlet and outlet differential temperature, inverter frequency) of the Oil Cooling Unit from the machine.

Communication method	Model	Installation position	Applicable model
Serial communication RS232C	AKZA-OP-CS	Daikin proprietary protocol	PIM00603
Serial communication RS232C	AKZA-OP-CSP		PIM00614
Parallel communication			

Note: For details on the communication procedure and specifications, refer to the dedicated instruction manual

### ■ Mounting the AKZA-OP-CS serial communication option board

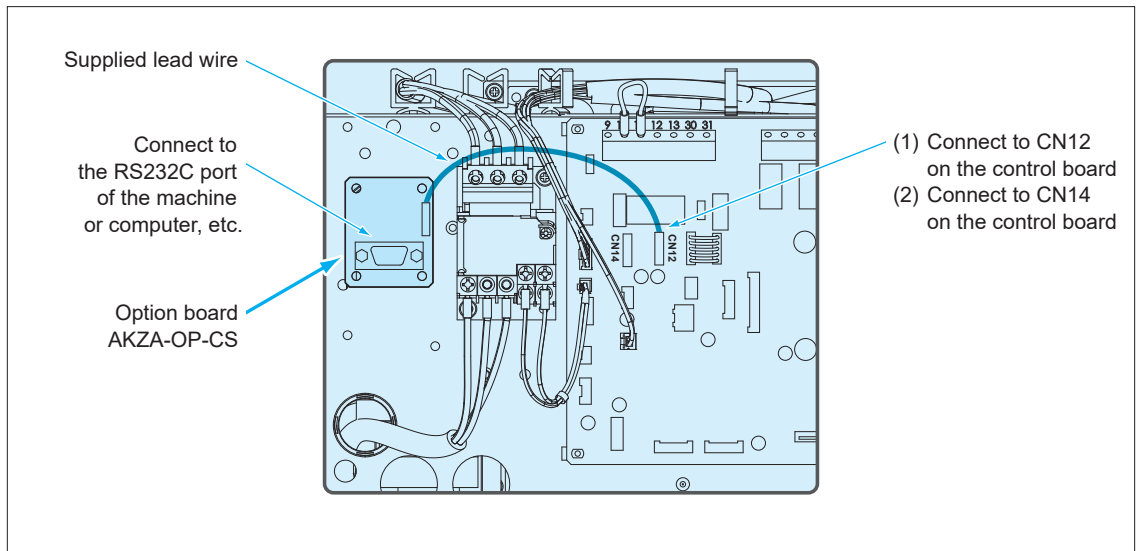

- Dimensions of communication board (W × H): 40 × 50
- The communication board is secured at four positions by locking support.

### ■ Mounting the AKZA-OP-CSP serial communication/parallel communication option board

The possible installation positions differ depending on the model.

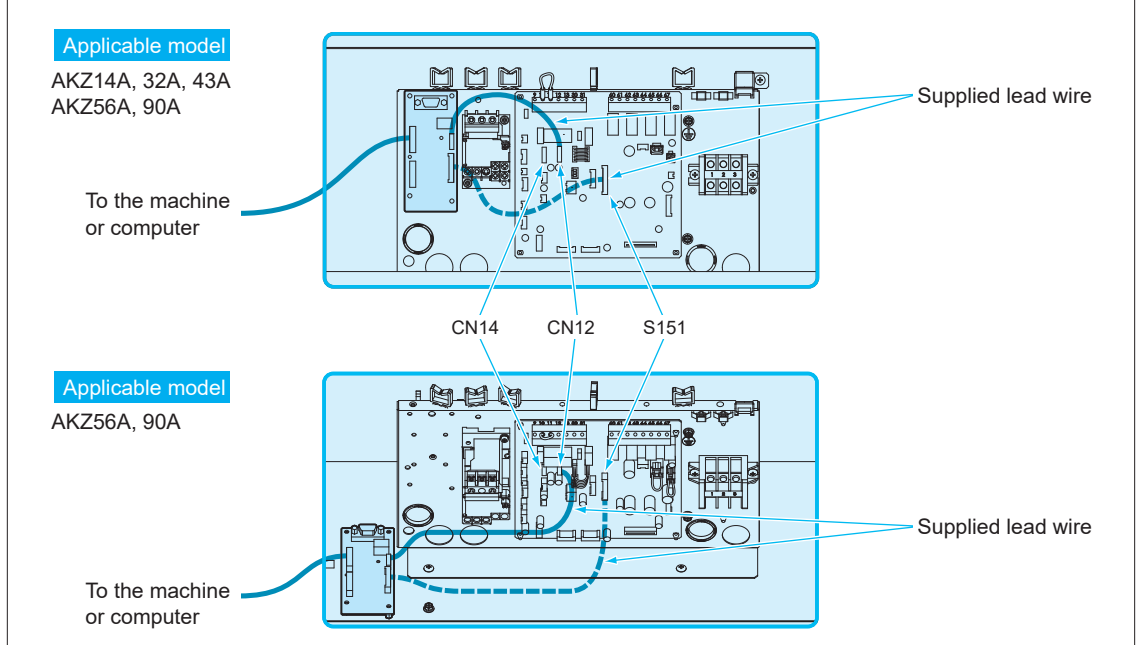

Part Names, Functions and Operation of Control Panel

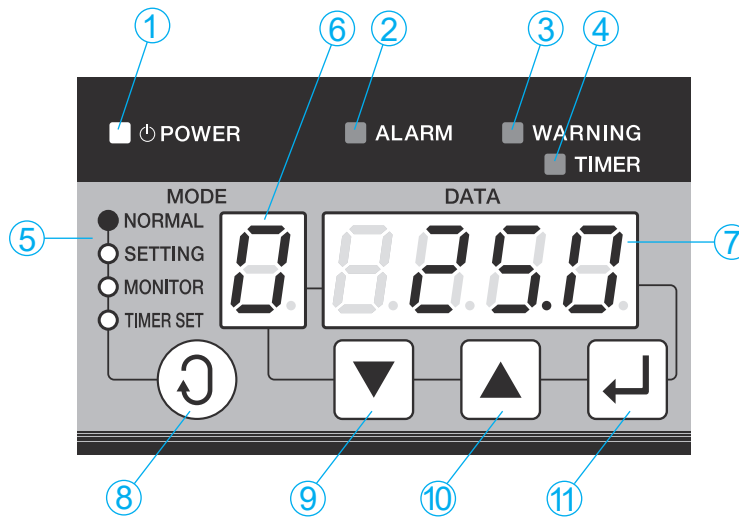

No.	Item	Description
①	Power lamp (Green)	The lamp is turned on while power is supplied.
②	Error warning lamp (Red)	When an error occurs Level 1 alarm: The lamp keeps blinking. Level 2 alarm: The lamp is continuously on.
③	Warning lamp (Green)	When a warning occurs Level 1 warning: The lamp keeps blinking. Level 2 warning: The lamp is turned on.
④	Timer mode lamp (Green)	The lamp keeps blinking while the machine is at a stop in the timer mode.
⑤	Operation mode display	Displays the mode of the control panel. NORMAL: Normal mode MONITOR: Monitor mode SETTING: Operation setting mode TIMER SET: Timer setting mode
⑥	Operation mode/ Data No. display	Displays the current operation mode (Normal mode/Operation setting mode) or data number of the data currently displayed on the data display.
⑦	Data display	Displays various data. The data displayed differs depending on the operation mode and data number.
⑧	[SELECT] (Select) key	Selects the operation mode.
⑨	[DOWN] key	Decrements the value of the operation mode, data number or data by 1 (0.1). When held for two seconds or longer, decrements the values by 10 (1).
⑩	[UP] key	Increases the value of the operation mode, data number or data by 1 (0.1). When held for two seconds or longer, increments the values by 10 (1).
⑪	[ENTER] (Determine) key	Determines the operation mode, data number, and data to be changed.

For details on alarms and warnings, refer to the instruction manual.

■ Operation for changing to each mode

The mode can be changed by operating the key in general.

To enter a special mode, hold down a number of keys in combination for more than five seconds.

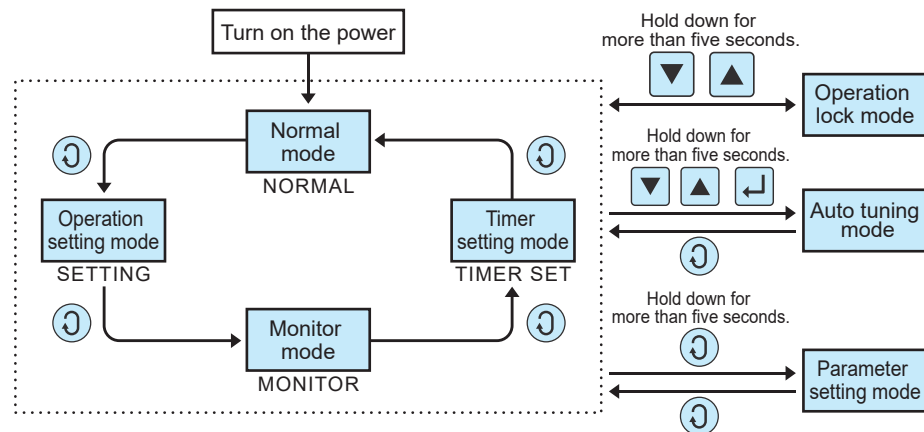

**CAUTION**

- The default setting is "Operation lock mode".  
To start operation, perform the unlocking operation as shown above.
- The default setting for operation on the standard machine is:  
Operation mode: 3 (Inlet oil temperature control, room temperature synchronization control)  
Differential temperature: 0.0 (°C)



## Operation Mode and Setting Method

Watch a video  
on the relationship between  
control and accuracy!



URL: [https://www.hyd.daikin.com/mv/oilcon\\_accuracy](https://www.hyd.daikin.com/mv/oilcon_accuracy)

### AKZ10 series

Operation mode No.	Mode name	Description	Setting temperature range	Necessary optional part
Operation mode 0	Inlet oil temperature, fixed temperature control	Keep the inlet oil temperature at the setting temperature within the range specified in the right column.	5 to 50°C	
Operation mode 1	Outlet oil temperature or return oil temperature control, fixed temperature control	Keep the outlet oil temperature or return oil temperature at the setting temperature within the range specified in the right column.	5 to 50°C	Oil temperature control thermistor (When return oil temperature is controlled)
Operation mode 3	Inlet oil temperature, room temperature synchronization control	Keep the inlet oil temperature at the setting temperature within the range specified in the right column.	Between Room temperature -9.9°C and Room temperature +9.9°C	
Operation mode 4	Inlet oil temperature, machine temperature synchronization control	Keep the inlet oil temperature at the setting temperature within the range specified in the right column.	Between Machine temperature -9.9°C and Machine temperature +9.9°C	Machine synchronization thermistor
Operation mode 5	Outlet oil temperature or return oil temperature control, room temperature synchronization control	Keep the outlet oil temperature or return oil temperature within the range specified in the right column.	Between Room temperature -9.9°C and Room temperature +9.9°C	Oil temperature control thermistor (When return oil temperature is controlled)
Operation mode 6	Outlet oil temperature or return oil temperature control, machine temperature synchronization control	Keep the outlet oil temperature or return oil temperature at the setting temperature within the range specified in the right column.	Between Machine temperature -9.9°C and Machine temperature +9.9°C	Oil temperature control thermistor (When return oil temperature is controlled) Machine synchronization thermistor

Note 1: Operation modes 2, 7, and 8 cannot be used. Note 2: Refer to Page 21 for details of required optional parts.

### Setting procedure

Default setting: Set to operation mode 3, and a temperature of 0.0°C  
To use the equipment other than at the default setting, change the setting by following the procedure below.

- Power ON ..... Release the operation lock mode before starting operation for the first time.  
(Hold down the  $\blacktriangledown$  and  $\blacktriangle$  keys simultaneously for more than 5 seconds.)
- Select the "SETTING" operation setting mode (press the  $\text{⌂}$  key once).

#### Changing the operation mode

Blinking

Decreases the "MODE" number by 1      Increases the "MODE" number by 1

- Set the operation mode by pressing the  $\blacktriangledown$  or  $\blacktriangle$  key.
- Confirm by pressing the  $\text{⌂}$  key.

#### Change the setting temperature

Blinking

The "Setting temperature" is reduced by 0.1      The "Setting temperature" is increased by 0.1.

- Set the temperature by pressing the  $\blacktriangledown$  or  $\blacktriangle$  key.
- Confirm by pressing the  $\text{⌂}$  key.

**7** To return to the "NORMAL" mode, press the  $\text{⌂}$  key three times.

## Points Checked in the Monitor Mode

The following points can be checked in the monitor mode.

Monitor No.	Description	Note	Monitor No.	Description	Note
0	Machine body temperature [Th1]	*1	5	$\Delta T$ (Th4-Th2)	*1
1	Outlet oil temperature or return oil temperature [Th2]	*1	6	Cooling capacity control command value (%)	-
2	Room temperature [Th3]	*1	7	Compressor inverter rotational speed (rps)	-
3	Inlet oil temperature [Th4]	*1	8	Power consumption (kW)	*2
4	Reserved [Th5]	*1	9	Extended DIN (hundreds digit), DOUT (tens digit) status	*3

\*1. If the thermistor is not connected or has a broken wire, -99.9 is displayed.

\*2. This is the value obtained by rough calculation under the following conditions: power supply voltage of 200 V, pump discharge pressure of 0.2 MPa (VG32: oil temperature 25°C). (Accuracy is approximately  $\pm 20\%$  with respect to the max. power consumption.) Contact us separately about pumpless machines.

\*3. With the default setting, 0 is displayed. Note that display is enabled when parameter n020 is "1" or the optional communication extension board is installed.

# Electric Wiring Diagram (Typical diagram)

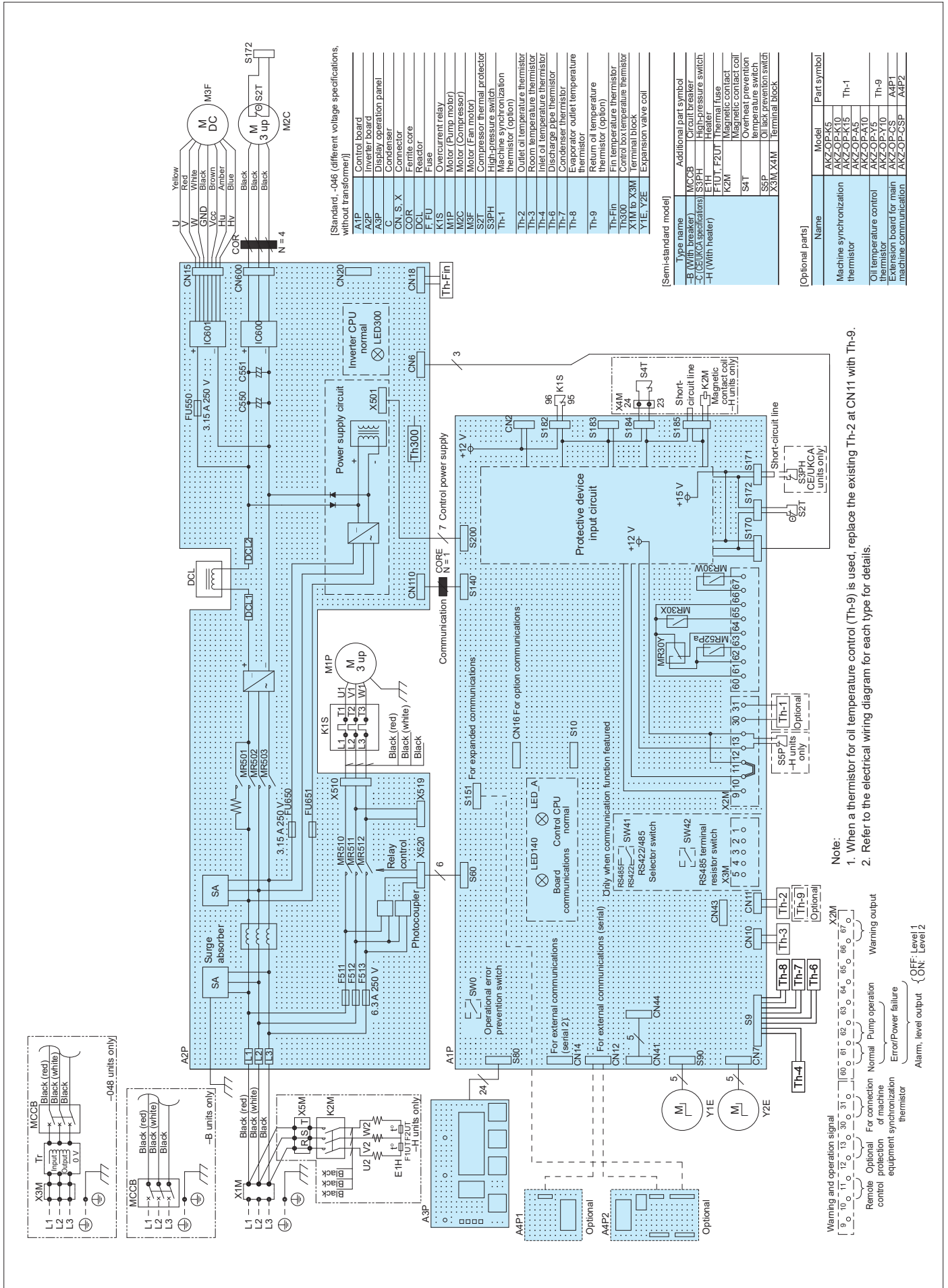

## Electric Wiring Connection Instruction

**1 Power supply capacity** ---Refer to the max. power consumption/max. current consumption in the specifications list (Pages 5 to 8).

**2 Connection to power supply terminal block (X1M)**

- (1) In the case of the standard type and menu-incorporating type (-C, -H, -T), connect the line to X1M.
- (2) In the case of "with breaker" (-B) specifications, connect to the circuit breaker.

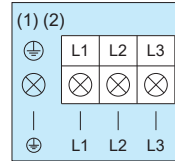

1. Screw terminal and wiring diameter

Series	Terminal block	Screw terminal	Wiring diameter	
			IEC cable	UL cable
AKZ 14A, 32A, 43A, 56A	X1M	M4, M5	2.5 mm <sup>2</sup> or greater	AWG#14 or greater
	Breaker	M5		
AKZ 90A	X1M	M5	4.0 mm <sup>2</sup> or greater	AWG#12 or greater
	Breaker	M5		

2. Use a round crimp-style terminal for connection.

3. The terminal block is for three poles and the earth wire is to be secured on the enclosure with a screw.

**3 Connection to signal terminal block (X2M)**

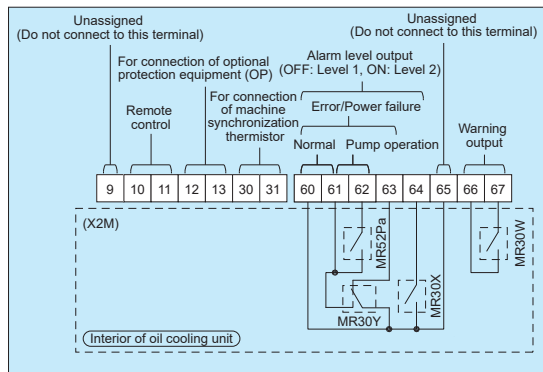

1. Straight crimp terminal and wiring diameter

Straight pin terminals	Wiring diameter	
	IEC cable	UL cable
*	0.3 mm <sup>2</sup> to 1.5 mm <sup>2</sup>	AWG#22 to #16

2. Use a straight crimp-style terminal for connection.

3. Use stranded wires for electric connection.

4. The wiring size is 0.5 mm<sup>2</sup> to 1.5 mm<sup>2</sup> in the case of duplex cable according to IEC.

If using stripped wires, make the stripped length 9 to 10 mm.

\*Recommended models and manufacturers:

TGN TC-1.25-9T (NICHIFU Co., Ltd.)

APA-1.25N (Daido Solderless Terminal)

**4 Signal output time chart**

**(1) Alarm/operation status output chart**

Operation status			Remote operation (between [10] and [11])							
			ON				OFF			
			Normal	Level 1 Error of LOCK	Level 2 Error	Power failure (Power OFF)	Normal	Level 1 Error of LOCK	Level 2 Error	Power failure (Power OFF)
Signal output										
Normal ("a" contact)	60-61	ON OFF								
Error/Stop (Power OFF) ("b" contact)	60-63	ON OFF								
Error level ("a" contact)	60-64	ON OFF								
Pump operation ("a" contact)	61-62	ON OFF								

**(2) Warning output chart**

Operation status			Non-warning status				Warning status			
			Normal	Level 1 Error of LOCK	Level 2 Error	Power failure (Power OFF)	Normal	Level 1 Error of LOCK	Level 2 Error	Power failure (Power OFF)
Signal output										
Warning output ("a" contact)	66-67	ON OFF								

**CAUTION**

1. The following electric wires can be used on the terminal block for straight crimp-style terminals.

Single wire:  $\phi 0.57$  to  $\phi 1.44$  (AWG#22 to #16)

Stranded wire: 0.25 mm<sup>2</sup> to 1.25 mm<sup>2</sup> (AWG#22 to 16)

2. Load applicable to [60 - 64] and [66 - 67] is as follows:

Min. applicable load: DC 10 mV 10  $\mu$ A or greater

Max. applicable load: DC 30 V, 2 A (Resistance load)

3. For [10] to [13], please prepare contacts to meet the condition of minimum applicable load DC 12 V and 5 mA.

4. When the length of the thermistor to be connected to [30] - [31] is longer than 10 m, or the wiring is routed in a poor noise environment, use shielded wire.

## Notes for Installing Piping Outside the Machine

If the external pressure loss (site piping resistance) exceeds the specified use range, phenomena such as abnormal noise of the pump (relief noise, noise of cavitation), decrease of cooling capacity and control failure of oil temperature may occur.

- Suction-side piping**  
Keep the suction vacuum pressure within the range between -30.7 and 0 kPa.  
The use of a suction filter of 100 to 150 mesh is recommended.
- Discharge-side piping**  
Keep the pressure loss of the discharge-side piping at 0.5 MPa or less.
- Do not install a stop valve on the suction or discharge side.**  
When a stop valve must be installed on the discharge side out of necessity, use a 0.5 Mpa relief valve along with the stop valve.
- Calculation of piping resistance**  
Determine the oil piping size by calculating the piping resistance according to the following equation:

$$\text{Piping resistance } \Delta P = 0.595 \times v \times Q \times L/D^4$$

(For use of general hydraulic oil and lubricant)

- $\Delta P$  : Piping resistance (MPa)
- $v$  : Dynamic coefficient of viscosity (mm<sup>2</sup>/s)  
-Refer to the Viscosity/Temperature Chart.
- $Q$  : Flow rate (L/min)
- $L$  : Piping length (m)
- $D$  : Internal piping diameter (mm)

### Relationship between oil flow rate and external pressure loss

An AKZ 10 series Oil Cooling Unit incorporating a pump of the circulation type has the characteristics shown below. When the external pressure loss ( $\Delta P$ ) is 0.5 MPa or less, the rated flow rate ( $Q_0$ ) is achieved, but when the external pressure loss exceeds 0.5 MPa, the flow rate becomes lower than the rated flow rate.

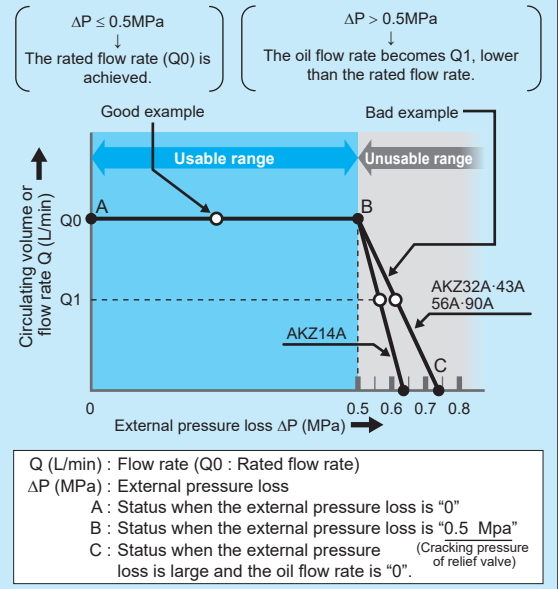

Note: Design the site piping to withstand a pressure of at least 1.0 Mpa.

### Viscosity/Temperature Chart

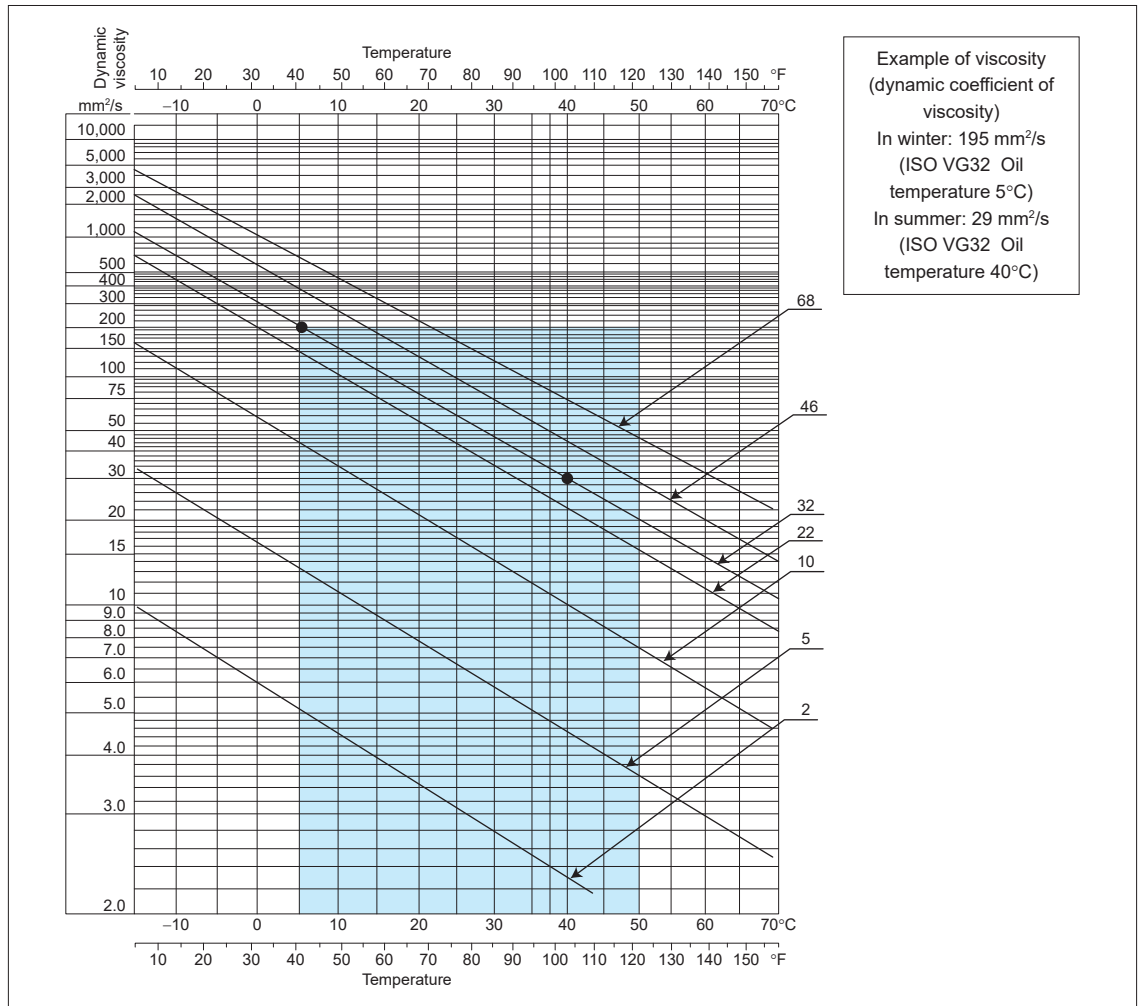

## Notes for Handling

### ● Important notes to be observed regarding the machine side (machine tools and industrial machinery)

1. When rough transport conditions are expected while transporting the machine overseas or elsewhere, special precautions should be taken in the packaging and transportation method so as to avoid the application of excessive force on the oil cooling unit (this unit).
2. The Oil Cooling Unit (this unit) does not incorporate a flow switch for checking the oil supply or a temperature switch for abnormal temperature (high temperature or low temperature) of oil supplied. So, please provide protection devices such as a flow switch and temperature switch.

### Notes for operation and cooling capacity

1. Do not use the oil cooling unit to cool oil from 50°C or higher. Start to operate the oil cooling unit at the same time as the machine or before the oil temperature rises to 40°C.
2. Do not place an object that hinders ventilation within 500 mm of the air-intake or exhaust.
3. If the air filter is clogged, the cooling capacity will be reduced. Clean the air filter (wash with warm water or clean with air) periodically once every two weeks to prevent clogging.

### Notes on usable fluids with oil cooling units



1. The cautions are given in the table below. (✓ symbol ... Can be used, "Unusable" ... Cannot be used)
2. Do not use fluid listed below as "Unusable"

	Description	AKZ10 series
<b>Lubricating oil</b> <b>Mineral hydraulic oil</b>	<ul style="list-style-type: none"> <li>• Oil that is classified as third class petroleum or fourth class petroleum of the fourth group hazardous materials stipulated in the Fire Defense Law and that corresponds to discoloration No. 1 in the copper corrosion test method (JIS K2513) of petroleum products</li> <li>• Oil that satisfies pollution level NAS 10</li> </ul>	✓
<b>Nonflammable hydraulic oil</b> <ul style="list-style-type: none"> <li>● Phosphate ester hydraulic fluid</li> <li>● Chlorinated hydrocarbon series</li> <li>● Water - Glycol series</li> <li>● W/O &amp; O/W emulsion series (High-aqueous hydraulic oil)</li> </ul>	—	Unusable
<b>Coolant fluid</b> <ul style="list-style-type: none"> <li>● Water-soluble cutting and grinding fluid</li> <li>● Non water-soluble cutting and grinding oil</li> </ul>	—	Unusable
<b>Ethylene glycol (Antifreeze liquid)</b>	—	Unusable
<b>Water (Industrial water)</b>	—	Unusable
<b>Inflammable liquids like fuel</b>	Liquid equivalent to special flammables, alcohol, first class petroleum and second class petroleum of the fourth group hazardous materials specified according to the Fire Defense Law	Unusable
<b>Chemicals</b>	—	Unusable
<b>Liquid for food products</b>	Drinking water, water for cooling food products, etc.	Unusable











## Notes for Handling

Before operating this unit, be sure to read the operation manual and properly understand it.





• **Instructions for safe operation**

Signs and Instructions	 <b>DANGER</b> ..... Failure to observe the instruction may cause an imminent hazardous situation that may result in personal death or serious injury.
	 <b>WARNING</b> ..... Failure to observe the instruction may result in personal death or serious injury.
	 <b>CAUTION</b> ..... Failure to observe the instruction may result in personal injury or damage to the property.



**① General instructions**

- [ **DANGER**] ① Use the equipment only in accordance with the intended specifications (specified in brochure, specification sheet, operation manual, and caution plates).
- [ **DANGER**] ② Never operate the equipment in an explosive atmosphere.
- [ **DANGER**] ③ Do not disassemble, repair or modify the equipment by yourself.
- [ **DANGER**] ④ Always comply with the laws and regulations for safety (Industrial Safety and Health Law, Fire Defense Law, and JIS B 8361 Guidelines of Hydraulic System).
- [ **WARNING**] ⑤ Caution in the event of refrigerant leak
  - Ventilate the room adequately (to avoid the risk of suffocation).
  - Avoid direct contact of the refrigerant with skin (to avoid the risk of cryogenic burns).
  - In the event of inhalation of a great deal of refrigerant, contact with skin, or refrigerant in the eye, seek medical attention immediately.
- [ **WARNING**] ⑥ In the event of an abnormal condition, stop operation promptly, investigate the cause of the problem and take appropriate remedial measures.
- [ **CAUTION**] ⑦ Do not use the unit in atypical environments (locations subject to high temperatures, high humidity, or a lot of dust, contamination, steam, oil mist or corrosive gases: H<sub>2</sub>S, SO<sub>2</sub>, NO<sub>2</sub> or Cl<sub>2</sub>).
- [ **CAUTION**] ⑧ Install a flow switch and temperature switch on the machine to protect the spindle and other components.
- [ **CAUTION**] ⑨ Do not get on the equipment or place an object on the equipment.
- [ **CAUTION**] ⑩ Use the unit at an altitude of up to 2,000 m. At altitudes in excess of 1,000 m the cooling capacity decreases by around 20 to 30%, so please select a model with adequate leeway in terms of cooling capacity.







**② Instructions for transportation**

- [ **DANGER**] ① When hoisting the equipment, check its weight and use the eye plates and hangers on it properly.
- [ **DANGER**] ② When hoisting the equipment, do not do so while it is fitted with a tank or anything else that you have provided.
- [ **WARNING**] ③ Do not approach the equipment while it is being hoisted and moved.
- [ **CAUTION**] ④ When moving the equipment, take appropriate measures for fall prevention.
- [ **CAUTION**] ⑤ Do not tilt the equipment 30 degrees or more while transporting it (including during storage).





**③ Instructions for installation**

- [ **WARNING**] ① Install the equipment on a rigid, level foundation and secure it appropriately.
- [ **CAUTION**] ② Do not place an object near the suction port or discharge port of the equipment.



**④ Instructions for wiring and piping installation**

- [ **DANGER**] ① Wiring and piping installation should be performed by a person with specialized knowledge and skills.
- [ **DANGER**] ② Always use a commercial power supply for the power source. (The use of an inverter power supply may cause burn damage).
- [ **DANGER**] ③ Connect the wiring for power supply in accordance with the electric wiring instruction diagram of the specification sheet and operation manual.
- [ **DANGER**] ④ Ground the equipment properly.
- [ **WARNING**] ⑤ Install the wiring in accordance with the standard by checking the electric wiring diagram.
- [ **CAUTION**] ⑥ Always install a dedicated all-pole (3-pole) earth leakage breaker appropriate for the capacity of Oil Cooling Unit on the main power supply on site.
- [ **CAUTION**] ⑦ Check that the oil piping has a pressure resistance of at least 1 MPa (and is usable at negative pressures too at the suction side) and install it reliably.









**⑤ Instructions for trial run**

- [ **CAUTION**] ① Check to see that the machine is in a safe status (not activated) before starting the trial run.
- [ **CAUTION**] ② Check to see that the oil piping and electric wiring are correctly connected to the machine and that there is no looseness in connections and joints.
- [ **CAUTION**] ③ Disable the operation lock of the equipment (Oil Cooling Unit) before starting the machine.
- [ **CAUTION**] ④ Check to see that the required amount of oil is in the oil piping system and that the piping is not blocked partway along.

**⑥ Instructions during operation**

- [ **DANGER**] ① Do not splash water or liquid on the equipment.
- [ **WARNING**] ② Do not push your finger or an object into gaps of the equipment.
- [ **CAUTION**] ③ Do not touch the heated exhaust port of the equipment.

**⑦ Instructions for maintenance and inspection**

- [ **DANGER**] ① Perform maintenance and inspection with the equipment kept open. Working in a closed status may result in suffocation due to the leak of refrigerant.
- [ **DANGER**] ② Always turn off the main power supply before starting maintenance and inspection.
- [ **DANGER**] ③ Wait for five minutes after turning off the main power supply before starting maintenance and inspection operation.
- [ **DANGER**] ④ Do not operate the equipment with its cover opened.
- [ **CAUTION**] ⑤ Wear protective gear such as gloves and an eye protector when performing maintenance, inspection and cleaning.
- [ **CAUTION**] ⑥ Clean the air filter periodically (once every two weeks in general).
- [ **CAUTION**] ⑦ Keep oil cleanliness to NAS 10 level or lower according to the pollution level.
- [ **CAUTION**] ⑧ Check the oil level in the tank and ensure that it is between the yellow line and the red line.
- [ **CAUTION**] ⑨ Inspect the underneath (drain pan) of the oil cooling unit once every six months, and if oil has accumulated, discharge it through the oil drainage port.

## Selection Method for Oil Cooling Units

Unit conversion formula • 1 kW = 860 kcal/h

1. Select an oil cooling unit with a cooling capacity **20 to 30% larger** than the amount of heat generated from the machine tool.
2. Since the cooling capacity of an oil cooling unit varies with changes in fluid temperature (fluid inlet temperature) and room temperature, the fluid temperature and room temperature conditions must be clarified in order to select the appropriate oil cooling unit.
3. Three methods are shown below as a guide to estimating the amount of heat generated from the machine tool. Ultimately, tests have to be conducted to determine the exact amount of heat generation for selecting the appropriate oil cooling unit.

### Example calculation 1 Estimating the amount of heat generation from the temperature difference between the inlet and outlet for oil going to the machine

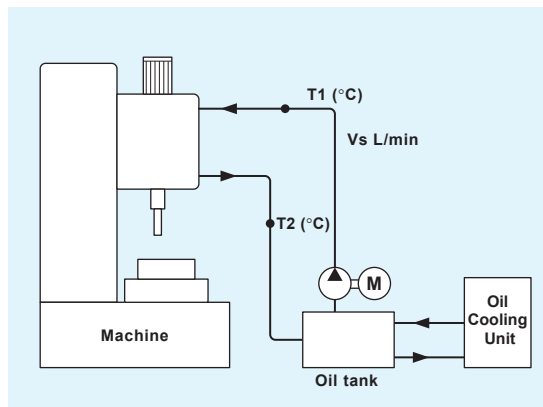

$$Q = \frac{Vs \times \rho \times Cp \times \Delta T}{1000 \times 60}$$

Q : Heat release value (kW)    Cp : Specific heat (kJ/kg·°C)  
 Vs : Flow rate (L/min)    ΔT : Temperature difference (°C)  
 ρ : Density (kg/m<sup>3</sup>)

**Example calculation** When "Vs" is 30 L/min and "ΔT" is 5°C

$$Q = \frac{30 \text{ L/min} \times 876 \text{ kg/m}^3 \times 1.97 \text{ kJ/kg}^\circ\text{C} \times 5^\circ\text{C}}{1000 \times 60} \approx 4.31 \text{ kW}$$

### Example calculation 2 When it is desired to reduce the temperature of the oil in the tank within a fixed time

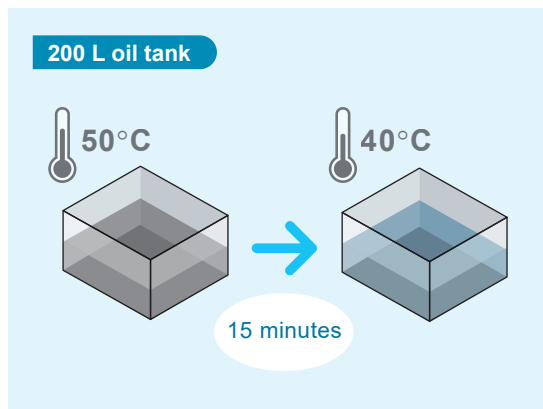

$$Q = \frac{V \times \rho \times Cp \times \Delta T}{1000 \times 60 \times t}$$

Q : Heat release value (kW)    Cp : Specific heat (kJ/kg·°C)  
 V : Tank oil capacity (L)    ΔT : Temperature difference (°C)  
 ρ : Density (kg/m<sup>3</sup>)    t : Time (min)

**Example calculation** When it is desired to cool 200 L of hydraulic oil from 50°C to 40°C within 15 minutes

$$Q = \frac{200 \text{ L} \times 876 \text{ kg/m}^3 \times 1.97 \text{ kJ/kg}^\circ\text{C} \times (50 - 40)^\circ\text{C}}{1000 \times 60 \times 15 \text{ min}}$$

A cooling capacity of **approx. 3.83 kW** or greater is required.

### Example calculation 3 When the motor output loss is considered to be the amount of heat generation

$$Q = H \cdot \frac{\eta}{100}$$

Q : Heat release value (kW)  
 H : Motor output (kW) ... For driving the spindle  
 η : Motor output loss (%)

**Example calculation** When the output loss is 30% with a motor output of 7.5 kW  
 → The output loss is 30% or so in general (Cooling of main shaft head)

$$Q = 7.5 \times 0.3 = 2.3 \text{ (kW)}$$

Note: Effect of heat absorption and dissipation from the surface of the tank and piping  
 Depending on the tank and piping surface area and ambient temperature, heat absorption and heat dissipation may increase. If the effect of heat absorption and heat dissipation is large, select a model with this effect taken into account.

#### Physical property values

Name of substance	Specific heat kJ/(kg·°C)	Density (kg/m <sup>3</sup> )
Water	4.18	998
Lubricating oil/hydraulic oil	1.97	876
Water-soluble coolant (10x dilution with water)	3.94 to 4.10	991
Aluminum	0.900	2710
Iron	0.460	7870
Copper	0.385	8960

\* The numbers in the table are reference values, so please use them as a guide.  
 \* All property values (some being calculated values) are at 20°C.



## OIL COOLING UNIT



**บริษัท นานดีอินเตอร์เทรด จำกัด**  
**NANDEE INTER-TRADE CO., LTD.**

314,316,318,320,322 ซอยจันทน์ 32 ถนนจันทน์ แขวงทุ่งวัดดอน เขตสาทร กทม. 10120

☎ : 0-2675-8239  
LINE : @nandeeintertrade  
f : nandeeintertrade  
🌐 : www.nandee.co.th  
✉ : marketing@nandee.co.th  
sales@nandee.co.th