

K Series

3.5MPa

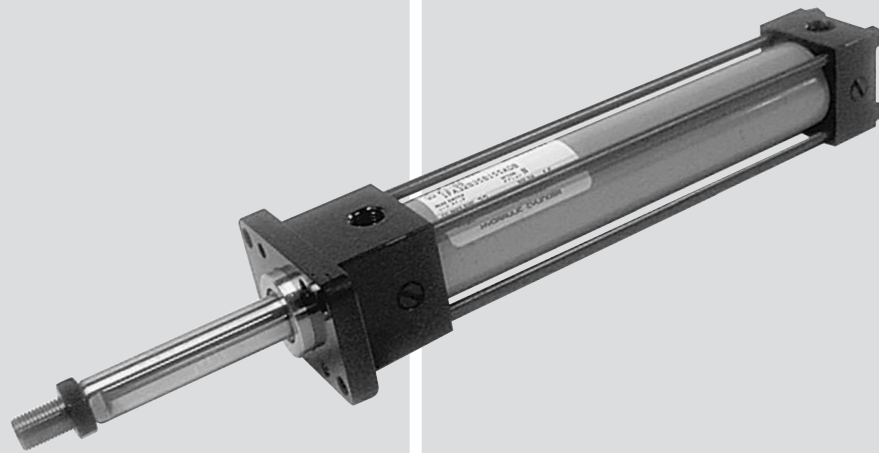

Tie Rod Type Cylinder

■ Features

Excellent Dependability

The rod is prevented being damaged by using a soft high-strength brass on the rod sliding surfaces for the chrome plating and rod bush of the high quality. An efficient U packing was adopted in Rod Packing. The gasket with the back pressure prevention ditch was adopted in piston packing. High reliability and durability to the oil leakage have been achieved.

Certain, steady operation

The piston uses a wear ring to prevent seizure, ensuring improved reliability. The cushion mechanism provides high accuracy, enabling reliable operation. Back-pressure preventive grooved packing is used for the piston packing.

Switch adjusted

As a standard feature, the KR series is equipped with the reliable high-performance switch (magnetic proximity switch), which provides excellent dust-proof structure. The compact, integrated structure enables efficient installation of the cylinder, without necessity of an external detector. With the LED indicator lamp, you can easily check operating status.

■ Specifications

Series Name	K	
Nominal Pressure <small>Note1)</small>	3.5MPa	
Model	Standard : K	Switch adjusted : KR
Bore	$\phi 32 \cdot \phi 40 \cdot \phi 50 \cdot \phi 63 \cdot \phi 80 \cdot \phi 100 \cdot \phi 125 \cdot \phi 160$	$\phi 32 \cdot \phi 40 \cdot \phi 50 \cdot \phi 63 \cdot \phi 80 \cdot \phi 100 \cdot \phi 125$ (Special size)
Maximum Allowable Pressure <small>Note2)</small>	4.4MPa	
Proof Pressure	5MPa	
Minimum Working Pressure <small>Note3)</small>	Less than 0.14MPa	
Thread Tolerance	JIS6g/6H (Corresponds to JIS Grade 2)	
Range of Operating Temperature <small>Note4)</small>	-10°C to +80°C	-10°C to +60°C
Hydraulic Oil Applied	General purpose mineral hydraulic oil (When using operating oils other than above, be sure to report the brand name(s) after referring to the Packing material.)	
Adjustment standard	Governed by Former JIS B 8354	

Note 1) The "Nominal Pressure" is the set pressure of the relief valve in the hydraulic circuit the cylinder uses.

Note 2) The Maximum Allowable Pressure is the tolerance value for pressures such as surge pressures and increased pressures, in the hydraulic cylinder circuit that exceed the pressure set for operation.

Note 3) The Minimum Working Pressure is the value when the pressure is supplied from the cap side.

Note 4) In switch adjusted specifications, the temperature limit for the switch body should be under 60°C.

(Select a special high-temperature switch when temperatures will exceed 60°C)

■ Ranges of Operating Speed

Bore	Range
$\phi 32$ to $\phi 160$	8 to 300mm/s

Note 1) When operating at the maximum cylinder speed, keep the inertial load pressures generated within the cylinder chamber below the Nominal Pressure.

Note 2) The Minimum Cylinder Speed does not include cushion stroke operation.

■ Maximum Stroke

Bore	Maximum Stroke
$\phi 32$ or $\phi 40$	1,000mm
$\phi 50$ or $\phi 63$	1,200mm
$\phi 80$ or $\phi 100$	1,600mm
$\phi 125$ to $\phi 160$	1,800mm

Note 1) This is the Maximum Stroke for the standard item produced.

Note 2) Please consider the rod buckling separately.

■ Stroke Tolerance: Grade A

Units:mm

Stroke	100 or less	101 to 250	251 to 630	631 to 1,000	1,001 to 1,600	1,601 to 2,000
Allowable Value	+0.8 0	+1.0 0	+1.25 0	+1.4 0	+1.6 0	+1.8 0

Note) The dimensions and precision of other parts conform to the former JIS B 8354 standard.

■ Mounting Type

Format	Code	Appearance	Format	Code	Appearance
Basic	S		Cap Side Rectangular Flange	FB	
Axial Right Angle Direction Foot	LA		Single Protrusion Clevis	CA	
			Double Protrusion Clevis	CB	
Axis Direction Foot	LB		Head Side Integral Trunnion	TA	
Head Side: Rectangular Flange	FA		Middle Trunnion	TC	

Note) (A)(B)(C)(D) are the positioning relationships for the port valve, etc.

■ Cushion Symbols

Code	B	R	H	N
Attachment Section	Cushion on Both Sides	Head-side Cushion	Cap-side Cushion	No Cushion

■ Cushion Ring Length

Units:mm

Code	φ32 to φ63	φ80 to φ125	φ160
Cushion Stroke	16	20	23

Note) Cushion ring is not tapered, but straight.

■ Tube Coating Colors

Standard

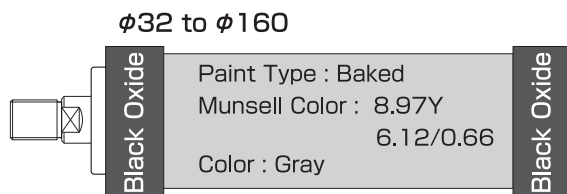

Switch Adjusted Specifications

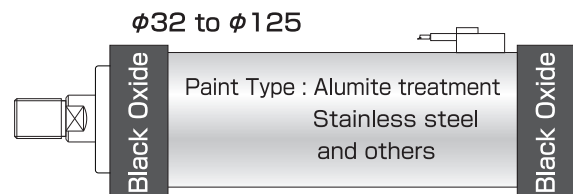

Note) If you have any questions with regard to the type of paint, please contact us.

Port/Valve Locations

In each of the dimension diagrams for mounting, the base position is given as A as seen from the rod side with the following positions expressed as BCD continuing in a clockwise direction.

- 1) The standard positions are: A……Port B……Cushion Valve C……Check Valve D……Air Bleed
- 2) In the case where differences from the standard positions have been specified, these are indicated by (A), (B), (C), (D).
- 3) In the case of no cushion, the standard positions are indicated by (A)⊙(D).
- 4) In the TA mounting format, the basic position for the head side is (A)⊙(C) or (A)⊙(C).
- 5) In the case where there is no air bleed, this is indicated by ⊖.
- 6) In the case where the head side and the cap side positions are different, they are indicated as (A)(B)(D) and (B)(C)(D) with the former being the head side and the latter being the cap side. In the case where they are depicted on two levels, the upper level is the cap side and the lower level is the head side.

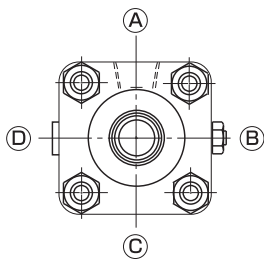

Slide Section Processing

Piston Rod : Hard chrome plating processing
(more than 2/100mm)

Packing Materials

Code	1
Material	Nitrile Rubber
Range of operating temperature	-10°C to +80°C
General-purpose mineral hydraulic oil	○
Emulsions of water in mineral oil	○
Emulsions of mineral oil in water	○
Water + Glycol-type Operating Oil	○
Phosphate ester fluid	×
Fatty acid ester fluid	○

Note 1) The ○ mark indicates its use is possible. The X mark indicates it is not possible to use it.

Note 2) There are neither Urethane Rubber nor Fluoric Rubber.

Theoretical Output Table

Bore	Rod Diameter (mm)	Piston Area (cm ²)		Theoretical Output (N)	
	S Rod	Push	Pull	Push	Pull
φ32	16	8.0	6.0	2,810	2,110
φ40	16	12.5	10.5	4,400	3,690
φ50	22.4	19.6	15.6	6,870	5,490
φ63	22.4	31.1	27.2	10,910	9,530
φ80	28	50.2	44.1	17,590	15,440
φ100	35.5	78.5	68.6	27,490	24,020
φ125	45	122.7	106.8	42,950	37,380
φ160	56	201.0	176.4	70,370	61,750

Code

The switch codes are not necessary for the K.

K **-SA** **1** **TC** **100** **S** **B** **320** **ABD** - - **Y** **P** **N** **J**
KR **-SA** **1** **TC** **100** **S** **B** **320** **ABD** - **2** **C** - **Y** **P** **N** **J**
 ① ② ③ ④ ⑤ ⑥ ⑦ ⑧ ⑨ ⑩ ⑪ ⑫ ⑬ ⑭ ⑮ ⑯ ⑰ ⑱ ⑲

① Series Name	K:3.5MPa
② Switch Adjusted Specifications	"R" is affixed in the case of cylinders with switch adjusted specifications. :KR
③ Single/Double Classification	S: Single Rod Type (Standard Type) W: Double Rod Type
④ Standard Special Classification <small>Note 1)</small>	A: Standard Dimensions
⑤ Packing Material	1. Nitrile Rubber (Standard)
⑥ Mounting	S·LA·LB·FA·FB·CA·CB·TA·TC
⑦ Bore (mm)	32·40·50·63·80·100·125·160 (Specification for switch adjusted : φ32 to φ100, but φ125 is special.)
⑧ Type of Rod	S: S Rod
⑨ Cushion Format	B: Cushion on Both Sides R: Head-side Cushion H: Cap-side Cushion N: No Cushion
⑩ Stroke Length (mm)	Indicate the stroke.
⑪ Port Location	Refer to P.58 and then indicate A, B, C or D.
⑫ Cushion Valve Location	Refer to P.58 and then indicate A, B, C or D. O: No Cushion or Fixed Cushion
⑬ Air Bleed Location	Refer to P.58 and then indicate A, B, C or D. No notation : Not necessary (Semi standard)
⑭ Switch Quantity <small>Note 2)</small>	Mentioned the quantity. 1A. When the switch is not needed in a switch-adjusted specifications.
⑮ Switch Type	C:TOV3 J:TOV5 CK:T5V3 CL:T5V5 DT:T2V3 DU:T2V5 CW:T2YV3 CH:TOH3 JH:TOH5 FJ: TOV-0.5 (For a DC connector system) FW: TOV-0.5 (For an AC connector system) XX: Special Part <div style="background-color: #e0e0e0; padding: 5px; text-align: center;">Please refer to P.138 for more detailed information on switches.</div>
⑯ End Joint	T: Single Protrusion End Joint Y: Double Protrusion End Joint F: F Connector No notation: None
⑰ Pin	P: CB When the Y joint has a pin attached P2: CB and the Y joint have a pin attached No notation: None
⑱ Lock Nut	N: Available(Lock nut with standard external thread is available as standard equipment.) N2: Two lock nuts
⑲ Bellows	J: Neoprene No entry: None (In the case where there are any other material specifications, please specify them.)

Note 1) The Special Standard Classification will be selected and mentioned at our company. Indicated in the product label.

Note 2) Switches are shipped unattached to prevent breakage.

S Single Rod

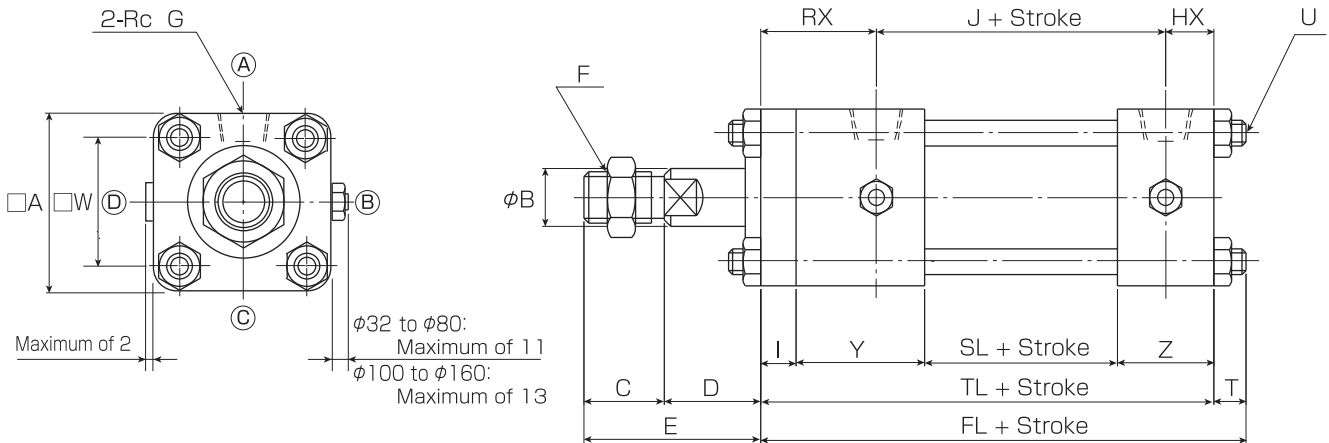
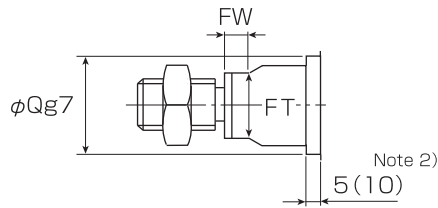

Note 1) (A),(B),(C),(D) are the positioning relationships of the port, valve, etc.

Note 2) () in figure is the dimension for the cylinder with additional bellows.

Note 3) Please note that the cushion valve of φ100 to φ160 comes off when loosening it too much and drops.

■ S Type Basic Table of Dimensions

[□ indicates no switch, switch adjusted specifications (up to φ100) are common ranges.]

Units:mm

Symbol Bore	Rod							D	TL	J	FL	RX	HX	SL	I	Y	Z	T	U	□A	□W	Rc G
	φB	C	E	F	φQ	FT	FW															
φ32	16	24	39	M12 P1.25	30	12	5	15	103	58	110	34	11	30	10	38	25	7	M6 P1.0	44	33	1/4
φ40	16	24	39	M12 P1.25	30	12	5	15	103	58	110	34	11	30	10	38	25	7	M6 P1.0	50	37	3/8
φ50	22.4	36	51	M18 P1.5	34	19	5	15	103	58	110	34	11	30	10	38	25	7	M6 P1.0	62	47	3/8
φ63	22.4	36	51	M18 P1.5	34	19	5	15	106	61	115	34	11	33	10	38	25	9	M8 P1.0	75	56	3/8
φ80	28	48	67	M24 P2.0	42	24	8	19	124	67	134	43	14	31	16	45	32	10	M10 P1.25	94	70	1/2
φ100	35.5	60	83	M30 P2.0	50	30	10	23	124	75	136	35	14	39	16	37	32	12	M12 P1.25	114	89	1/2
φ125	45	84	109	M42 P2.0	60	41	15	25	134 (144)	75 (85)	150 (160)	45	14	39 (49)	20	43	32	16	M16 P1.5	138	110	1/2
φ160	56	96	125	M48 P2.0	72	50	15	29	155	88	174	50	17	46	25	46	38	19	M20 P1.5	178	142	3/4

Note) The dimensions in () are special dimensions for switch adjusted specification.

S Double Rod

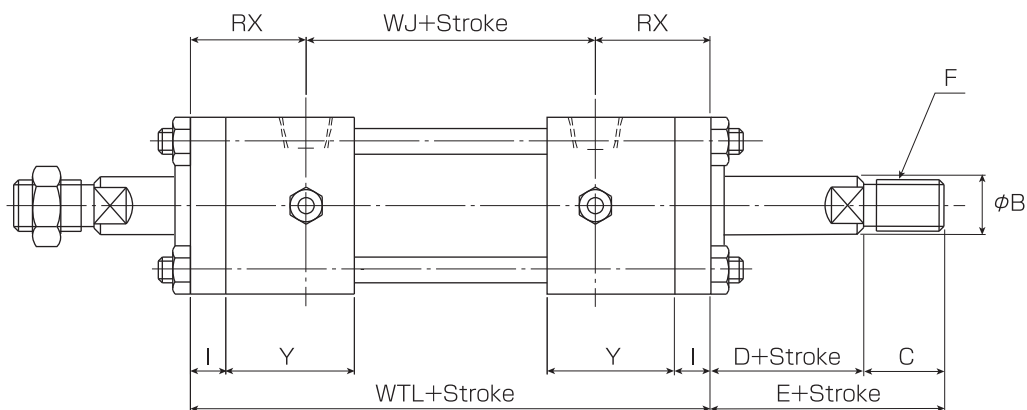

■ Double Rod

Units:mm

Symbol Bore	WTL	WJ
φ32	132	64
φ40	136	68
φ50	136	68
φ63	136	68
φ80	162	76
φ100	151	81
φ125	165 (188)	75 (98)
φ160	188	88

LA Single Rod

※ When the port position is (B) or (D) position

Units:mm

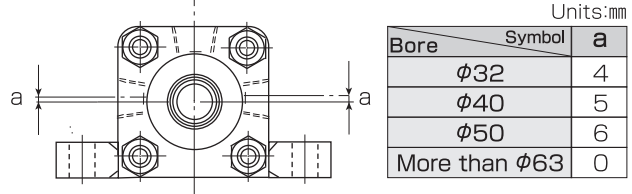
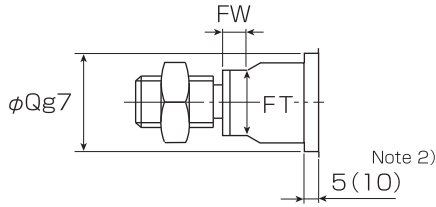

Bore	Symbol	a
φ32		4
φ40		5
φ50		6
More than φ63		0

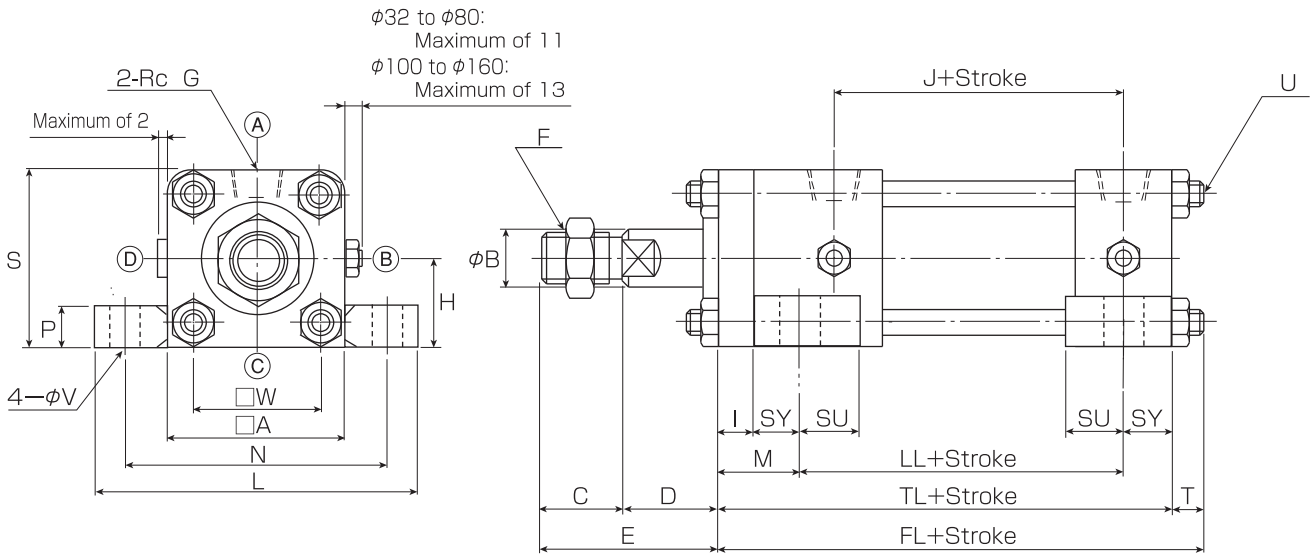

Note 1) (A),(B),(C),(D) are the positioning relationships of the port, valve, etc.

Note 2) () in figure is the dimension for the cylinder with additional bellows.

Note 3) Please note that the cushion valve of φ100 to φ160 comes off when loosening it too much and drops.

LA Type Basic Table of Dimensions

[□ indicates no switch, switch adjusted specifications (up to φ140) are common ranges.]

Units:mm

Symbol Bore	Rod				D	TL	J	LL	FL	I	M	T	SU	SY	U	□A	□W	N	L	P	H	S	φV	RcG
	φB	C	E	F																				
φ32	16	24	39	M12 P1.25	15	103	58	73	110	10	20	7	18	10	M6 P1.0	44	32	69	84	8	22 ^{-0.300} _{-0.384}	44	9	1/4
φ40	16	24	39	M12 P1.25	15	103	58	73	110	10	20	7	24	10	M6 P1.0	50	37	80	100	8	25 ^{-0.300} _{-0.384}	50	12	3/8
φ50	22.4	36	51	M18 P1.5	15	103	58	73	110	10	20	7	24	10	M6 P1.0	62	47	92	112	12	31 ^{-0.310} _{-0.410}	62	12	3/8
φ63	22.4	36	51	M18 P1.5	15	106	61	76	115	10	20	9	24	10	M8 P1.0	75	56	108	128	12	38 ^{-0.310} _{-0.410}	76	12	3/8
φ80	28	48	67	M24 P2.0	19	124	67	82	134	16	29	10	32	13	M10 P1.25	94	70	128	150	19	47 ^{-0.320} _{-0.420}	94	14	1/2
φ100	35.5	60	83	M30 P2.0	23	124	75	72	136	16	34	12	27	18	M12 P1.25	114	89	154	182	24	57 ^{-0.340} _{-0.460}	114	18	1/2
φ125	45	84	109	M42 P2.0	25	134 (144)	75 (85)	70 (80)	150 (160)	20	42	16	23	22	M16 P1.5	138	110	189	224	29	69 ^{-0.360} _{-0.480}	138	22	1/2
φ160	56	96	125	M48 P2.0	29	155	88	82	174	25	49	19	26	24	M20 P1.5	178	142	236	278	42	89 ^{-0.380} _{-0.520}	178	26	3/4

Note1) The dimensions in () are special dimensions for switch adjusted specification.

Note2) Please refer to the S Type specifications on P.60 for the wrench-hold specifics (both sides).

LA Double Rod

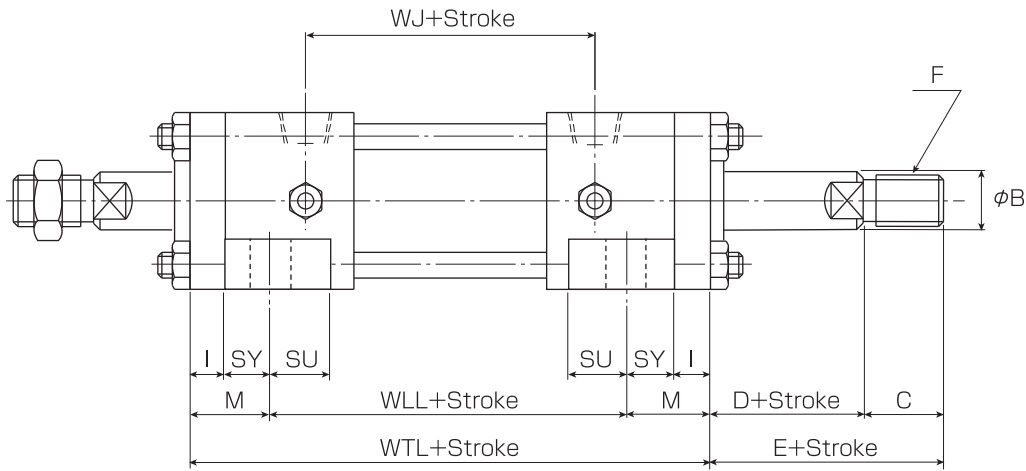

■ Double Rod Units:mm

Symbol Bore	WTL	WJ	WLL
φ32	132	64	92
φ40	136	68	96
φ50	136	68	96
φ63	136	68	96
φ80	162	76	104
φ100	151	81	83
φ125	165 (188)	75 (98)	81 (104)
φ160	188	88	90

LB Single Rod

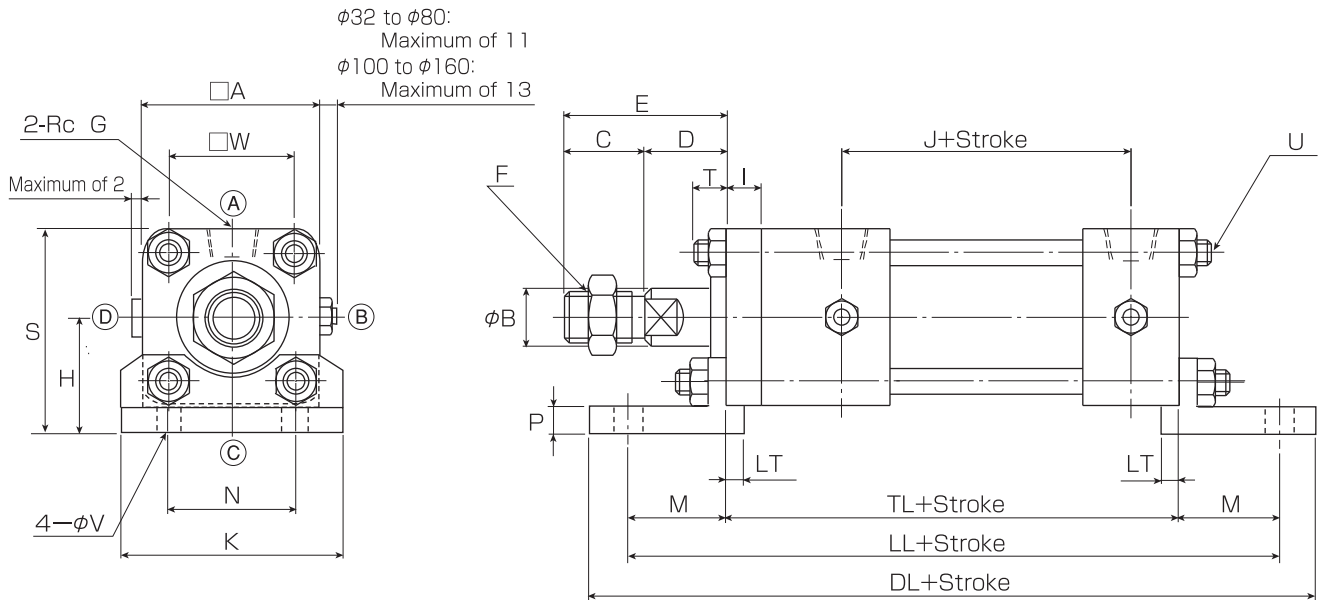
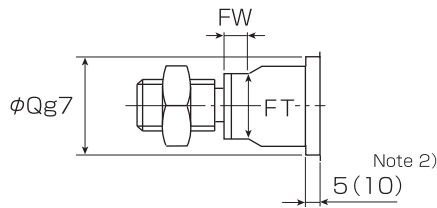

Note 1) (A),(B),(C),(D) are the positioning relationships of the port, valve, etc.

Note 2) () in figure is the dimension for the cylinder with additional bellows.

Note 3) Please note that the cushion valve of φ100 to φ160 comes off when loosening it too much and drops.

LB Type Basic Table of Dimensions

[□ indicates no switch, switch adjusted specifications (up to φ100) are common ranges.]

Units:mm

Symbol Bore	Rod				D	TL	J	I	LL	DL	M	LT	P	T	U	□A	□W	N	K	H	S	φV	RcG
	φB	C	E	F																			
φ32	16	24	39	M12 P1.25	15	103	58	10	149	169	23	(3)	5	7	M6 P1.0	44	33	33	54	33	55	9	1/4
φ40	16	24	39	M12 P1.25	15	103	58	10	153	177	25	(3)	5	7	M6 P1.0	50	37	37	60	35	60	12	3/8
φ50	22.4	36	51	M18 P1.5	15	103	58	10	155	179	26	(3)	6	7	M6 P1.0	62	47	47	70	41	72	12	3/8
φ63	22.4	36	51	M18 P1.5	15	106	61	10	162	186	28	(3)	6	9	M8 P1.0	75	56	56	80	48	85.5	12	3/8
φ80	28	48	67	M24 P2.0	19	124	67	16	192	220	34	(3)	8	10	M10 P1.25	94	70	70	97	59	106	14	1/2
φ100	35.5	60	83	M30 P2.0	23	124	75	16	204	240	40	(3)	9	12	M12 P1.25	114	89	89	120	70	127	18	1/2
φ125	45	84	109	M42 P2.0	25	134 (144)	75 (85)	20	228 (238)	272 (282)	47	0	10	16	M16 P1.5	138	110	95	138	86	155	22	1/2
φ160	56	96	125	M48 P2.0	29	155	88	25	271	323	58	0	15	19	M20 P1.5	178	142	128	178	111	200	26	3/4

Note1) The dimensions in () are special dimensions for switch adjusted specification.

Note2) Please refer to the S Type specifications on P.60 for the wrench-hold specifics (both sides).

LB Double Rod

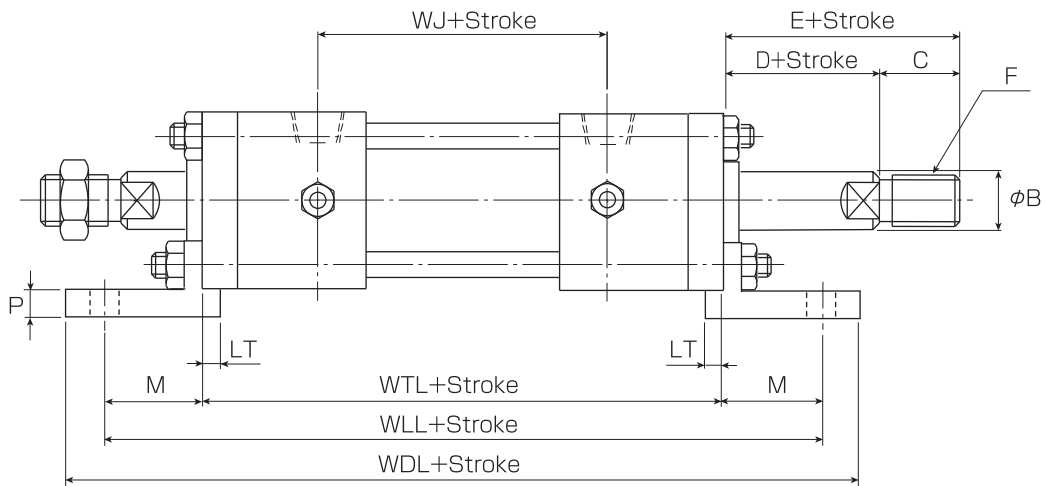

■ Double Rod Units:mm

Symbol Bore	WTL	WJ	WLL	WDL
φ32	132	64	178	198
φ40	136	68	186	210
φ50	136	68	188	212
φ63	136	68	192	216
φ80	162	76	230	258
φ100	151	81	231	267
φ125	165 (188)	75 (98)	259 (282)	303 (326)
φ160	188	88	304	356

FA Single Rod

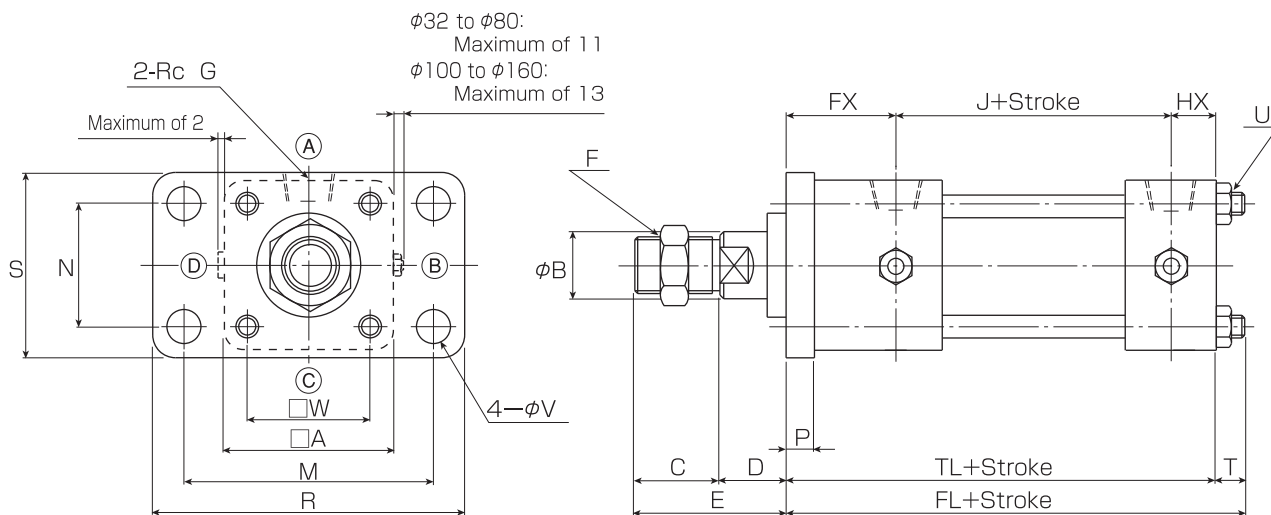
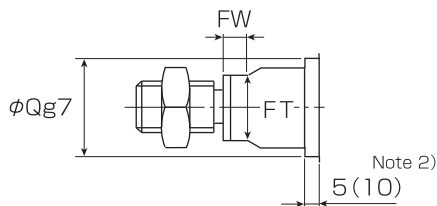

Note 1) (A),(B),(C),(D) are the positioning relationships of the port, valve, etc.

Note 2) () in figure is the dimension for the cylinder with additional bellows.

Note 3) Please note that the cushion valve of $\phi 100$ to $\phi 160$ comes off when loosening it too much and drops.

FA Type Basic Table of Dimensions

[□ indicates no switch, switch adjusted specifications (up to $\phi 100$) are common ranges.]

Units:mm

Symbol Bore	□ッド				D	TL	J	FL	FX	HX	P	T	U	□A	□W	M	R	N	S	φV	RcG
	φB	C	E	F																	
φ32	16	24	39	M12 P1.25	15	103	58	110	34	11	10	7	M6 P1.0	44	33	58	72	33	47	7	1/4
φ40	16	24	39	M12 P1.25	15	103	58	110	34	11	10	7	M6 P1.0	50	37	70	84	36	52	7	3/8
φ50	22.4	36	51	M18 P1.5	15	103	58	110	34	11	10	7	M6 P1.0	62	47	86	104	47	65	9	3/8
φ63	22.4	36	51	M18 P1.5	15	106	61	115	34	11	10	9	M8 P1.0	75	56	98	116	56	76	9	3/8
φ80	28	48	67	M24 P2.0	19	124	67	134	43	14	16	10	M10 P1.25	94	70	119	143	70	95	12	1/2
φ100	35.5	60	83	M30 P2.0	23	124	75	136	35	14	16	12	M12 P1.25	114	89	140	166	84	115	14	1/2
φ125	45	84	109	M42 P2.0	25	134 (144)	75 (85)	150 (160)	45	14	20	16	M16 P1.5	138	110	176	212	110	138	18	1/2
φ160	56	96	125	M48 P2.0	29	155	88	174	50	17	25	19	M20 P1.5	178	142	225	270	142	178	22	3/4

Note1) The dimensions in () are special dimensions for switch adjusted specification.

Note2) Please refer to the S Type specifications on P.60 for the wrench-hold specifics (both sides).

FA Double Rod

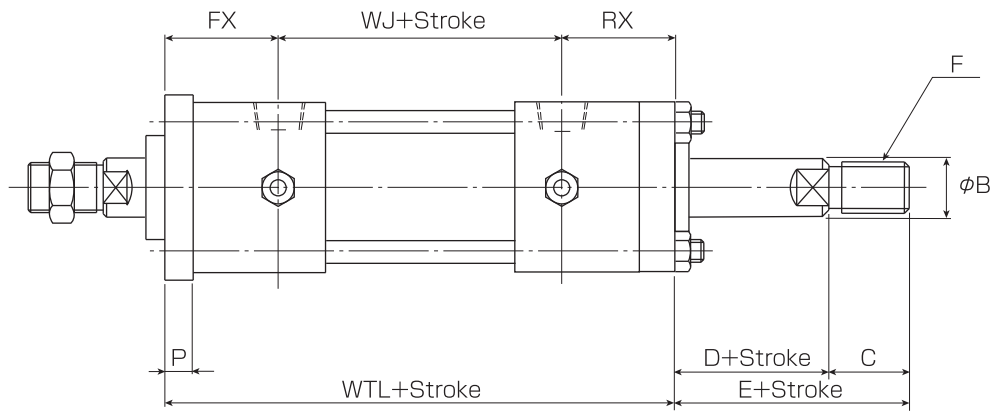

■ Double Rod Units:mm

Symbol Bore	WTL	WJ	RX
φ32	132	64	34
φ40	136	68	34
φ50	136	68	34
φ63	136	68	34
φ80	162	76	43
φ100	151	81	35
φ125	165 (188)	75 (98)	45
φ160	188	88	50

FB Single Rod

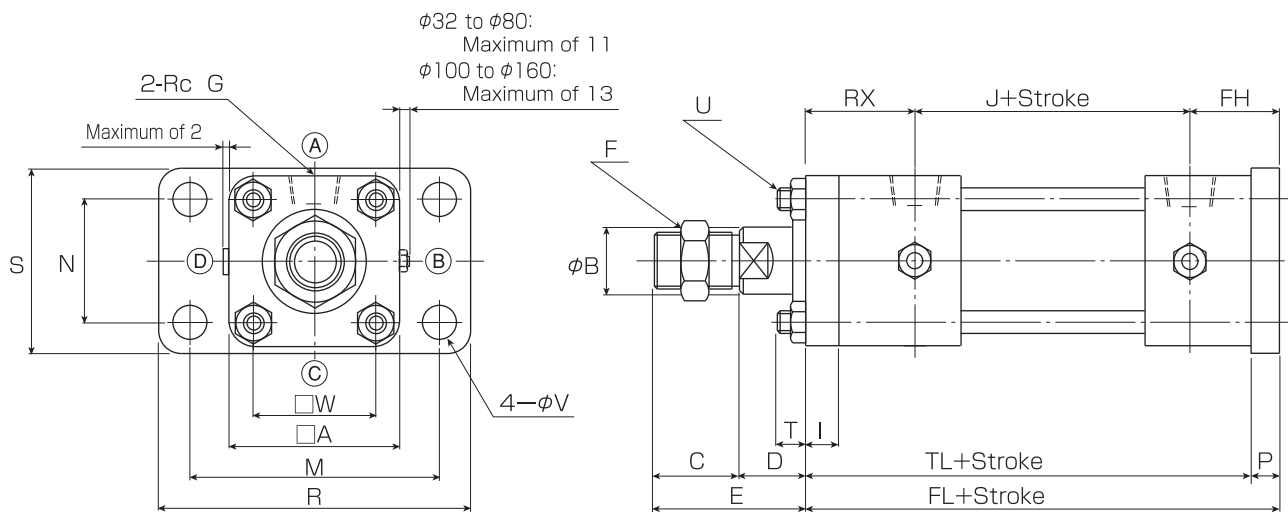
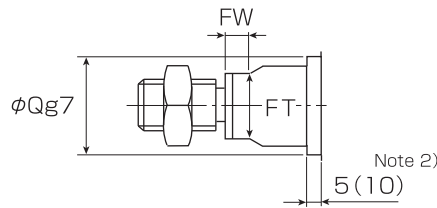

Note 1) A, B, C, D are the positioning relationships of the port, valve, etc.

Note 2) () in figure is the dimension for the cylinder with additional bellows.

Note 3) Please note that the cushion valve of $\phi 100$ to $\phi 160$ comes off when loosening it too much and drops.

FB Type Basic Table of Dimensions

[indicates no switch, switch adjusted specifications (up to $\phi 100$) are common ranges.]

Units:mm

Symbol Bore	Rod				D	TL	J	FL	RX	FX	P	T	I	U	□A	□W	M	R	N	S	ϕV	RcG
	ϕB	C	E	F																		
$\phi 32$	16	24	39	M12 P1.25	15	103	58	113	34	21	10	7	10	M6 P1.0	44	33	58	72	33	47	7	1/4
$\phi 40$	16	24	39	M12 P1.25	15	103	58	113	34	21	10	7	10	M6 P1.0	50	37	70	84	36	52	7	3/8
$\phi 50$	22.4	36	51	M18 P1.5	15	103	58	113	34	21	10	7	10	M6 P1.0	62	47	86	104	47	65	9	3/8
$\phi 63$	22.4	36	51	M18 P1.5	15	106	61	116	34	21	10	9	10	M8 P1.0	75	56	98	116	56	76	9	3/8
$\phi 80$	28	48	67	M24 P2.0	19	124	67	140	43	30	16	10	16	M10 P1.25	94	70	119	143	70	95	12	1/2
$\phi 100$	35.5	60	83	M30 P2.0	23	124	75	140	35	30	16	12	16	M12 P1.25	114	89	140	166	84	115	14	1/2
$\phi 125$	45	84	109	M42 P2.0	25	134 (144)	75 (85)	154 (164)	45	34	20	16	20	M16 P1.5	138	110	176	212	110	138	18	1/2
$\phi 160$	56	96	125	M48 P2.0	29	155	88	180	50	42	25	19	25	M20 P1.5	178	142	225	270	142	178	22	3/4

Note1) The dimensions in () are special dimensions for switch adjusted specification.

Note2) Please refer to the S Type specifications on P.60 for the wrench-hold specifics (both sides).

CA Single Rod

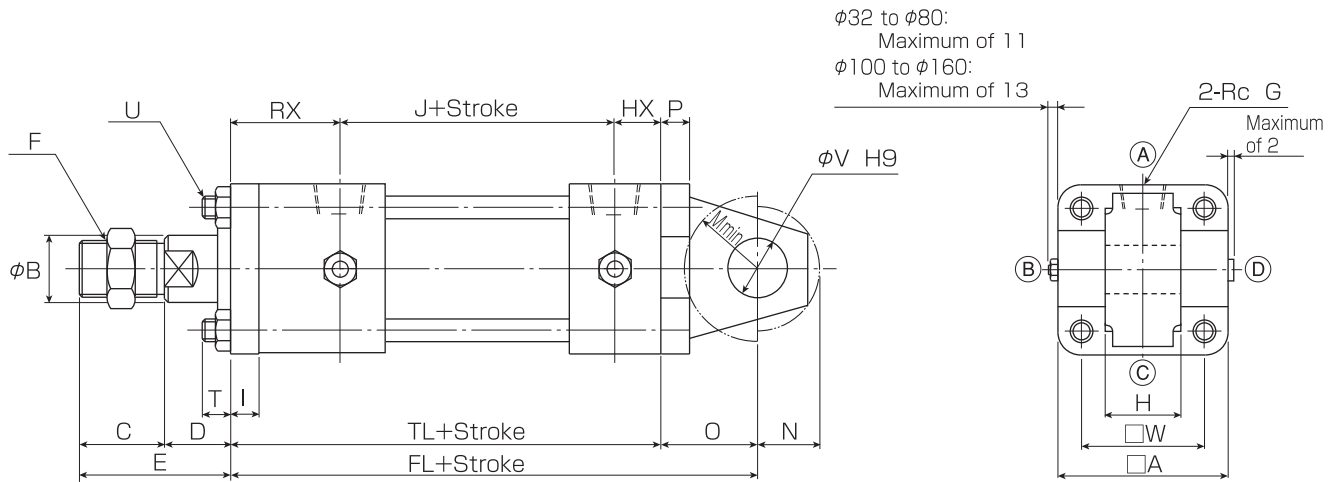
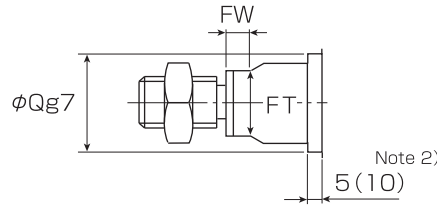

Note 1) (A),(B),(C),(D) are the positioning relationships of the port, valve, etc.

Note 2) () in figure is the dimension for the cylinder with additional bellows.

Note 3) Please note that the cushion valve of $\phi 100$ to $\phi 160$ comes off when loosening it too much and drops.

CA Type Basic Table of Dimensions

[□ indicates no switch, switch adjusted specifications (up to $\phi 100$) are common ranges.]

Units:mm

記号 内径	ロッド				D	TL	J	FL	RX	HX	P	T	I	M	N	O	ϕV	U	□A	□W	H	RcG
	ϕB	C	E	F																		
$\phi 32$	16	24	39	M12 P1.25	15	103	58	122	34	11	8	7	10	R17	R14	19	12	M6 P1.0	44	33	16 ⁰ _{-0.070}	1/4
$\phi 40$	16	24	39	M12 P1.25	15	103	58	122	34	11	8	7	10	R17	R16	19	14	M6 P1.0	50	37	20 ⁰ _{-0.084}	3/8
$\phi 50$	22.4	36	51	M18 P1.5	15	103	58	122	34	11	10	7	10	R19	R16	19	14	M6 P1.0	62	47	20 ⁰ _{-0.084}	3/8
$\phi 63$	22.4	36	51	M18 P1.5	15	106	61	125	34	11	13	9	10	R19	R16	19	14	M8 P1.0	75	56	20 ⁰ _{-0.084}	3/8
$\phi 80$	28	48	67	M24 P2.0	19	124	67	156	43	14	18	10	16	R26	R22	32	20	M10 P1.25	94	70	32 ⁰ _{-0.100}	1/2
$\phi 100$	35.5	60	83	M30 P2.0	23	124	75	177	35	14	16	12	16	R32	R30	53	25	M12 P1.25	114	89	40 ⁰ _{-0.100}	1/2
$\phi 125$	45	84	109	M42 P2.0	25	134 (144)	75 (85)	201 (211)	45	14	19	16	20	R42	R36	67	32	M16 P1.5	138	110	45 ⁰ _{-0.100}	1/2
$\phi 160$	56	96	125	M48 P2.0	29	155	88	232	50	17	24	19	25	R45	R42	77	36	M20 P1.5	178	142	50 ⁰ _{-0.100}	3/4

Note1) The dimensions in () are special dimensions for switch adjusted specification.

Note2) Please refer to the S Type specifications on P.60 for the wrench-hold specifics (both sides).

CB Single Rod

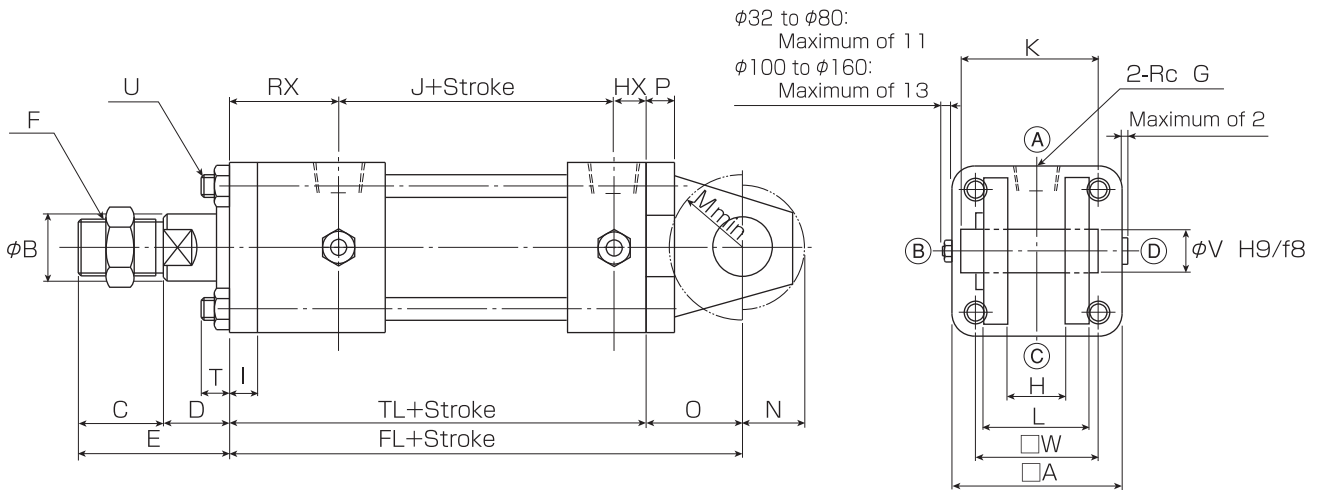
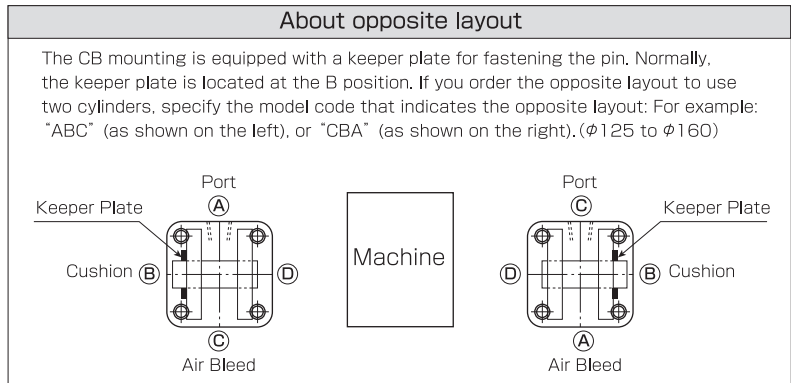
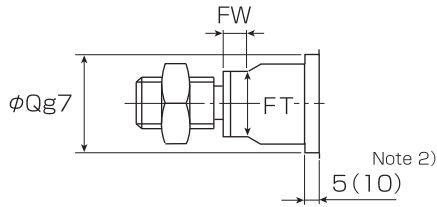

- Note 1) (A), (B), (C), (D) are the positioning relationships of the port, valve, etc.
- Note 2) Pins are included as standard up to $\phi 125$. $\phi 160$ becomes optional.
- Note 3) () in figure is the dimension for the cylinder with additional bellows..
- Note 4) Please note that the cushion valve of $\phi 100$ to $\phi 160$ comes off when loosening it too much and drops.

CB Type Basic Table of Dimensions

[] indicates no switch, switch adjusted specifications (up to $\phi 100$) are common ranges.]

Units:mm

Symbol Bore	Rod				D	TL	J	FL	RX	HX	P	T	I	M	N	O	ϕV	U	□A	□W	H	L	K	RcG
	ϕB	C	E	F																				
$\phi 32$	16	24	39	M12 P1.25	15	103	58	122	34	11	8	7	10	R18	R15	19	12	M6 P1.0	44	33	16 ^{+0.7} _{+0.5}	32	46	1/4
$\phi 40$	16	24	39	M12 P1.25	15	103	58	122	34	11	8	7	10	R18	R15	19	14	M6 P1.0	50	37	20 ^{+0.7} _{+0.5}	44	58	3/8
$\phi 50$	22.4	36	51	M18 P1.5	15	103	58	122	34	11	8	7	10	R19	R17	19	14	M6 P1.0	62	47	20 ^{+0.7} _{+0.5}	52	66	3/8
$\phi 63$	22.4	36	51	M18 P1.5	15	106	61	125	34	11	8	9	10	R19	R17	19	14	M8 P1.0	75	56	20 ^{+0.7} _{+0.5}	52	66	3/8
$\phi 80$	28	48	67	M24 P2.0	19	124	67	156	43	14	11	10	16	R32	R23	32	20	M10 P1.25	94	70	32 ^{+0.7} _{+0.5}	64	78	1/2
$\phi 100$	35.5	60	83	M30 P2.0	23	124	75	177	35	14	16	12	16	R32	R30	53	25	M12 P1.25	114	89	40 ^{+0.7} _{+0.5}	80	94	1/2
$\phi 125$	45	84	109	M42 P2.0	25	134 (144)	75 (85)	201 (211)	45	14	19	16	20	R42	R36	67	32	M16 P1.5	138	110	45 ^{+0.7} _{+0.5}	90	105	1/2
$\phi 160$	56	96	125	M48 P2.0	29	155	88	232	50	17	24	19	25	R45	R42	77	36	M20 P1.5	178	142	50 ^{+0.7} _{+0.5}	100	115	3/4

- Note1) The dimensions in () are special dimensions for switch adjusted specification.
- Note2) Please refer to the S Type specifications on P.60 for the wrench-hold specifics (both sides).

Table of Dimensions for CB

Pin

Bore	Material
$\phi 32$ to $\phi 160$	Carbon Steel for Machine Structural Use

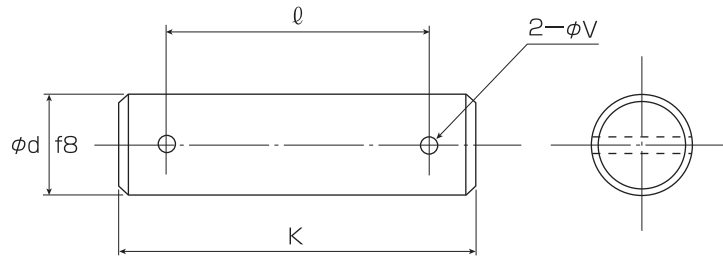

$\phi 32$ to $\phi 100$

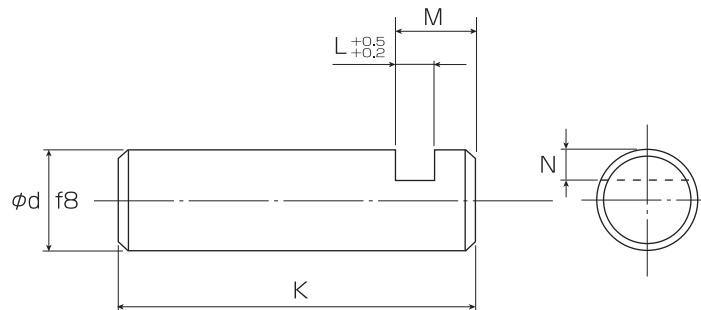

$\phi 125$ to $\phi 160$

Table of Dimensions

Units:mm

Symbol Bore	ϕd	L	M	N	K	V	ℓ
$\phi 32$	12	—	—	—	46	2.5	38
$\phi 40$	14	—	—	—	58	2.5	50
$\phi 50$	14	—	—	—	66	2.5	58
$\phi 63$	14	—	—	—	66	2.5	58
$\phi 80$	20	—	—	—	78	2.5	70
$\phi 100$	25	—	—	—	94	2.5	86
$\phi 125$	32	5	10	5.5	105	—	—
$\phi 160$	36	5	10	5.5	115	—	—

Note) For up to $\phi 100$, a split pin is used to fasten the pin.

Keeper Plate

Bore	Material
$\phi 125$ to $\phi 160$	Rolled Steel for General Structure

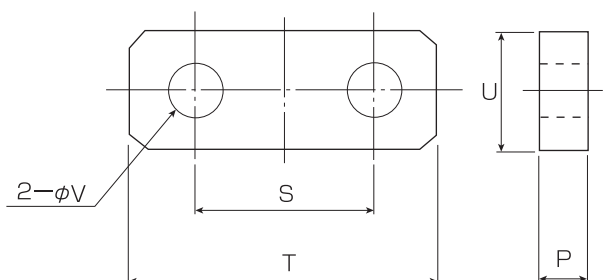
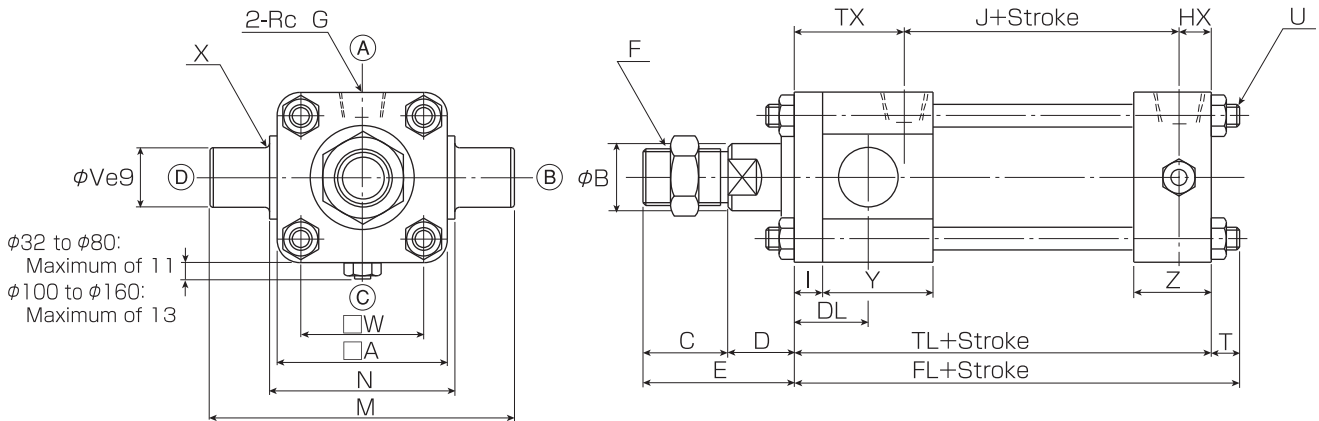
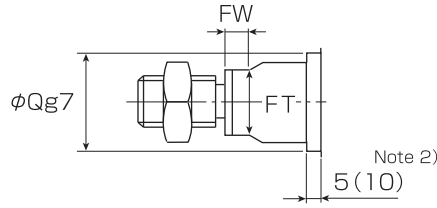

Table of Dimensions

Units:mm

Symbol Bore	V	U	P	S	T	With Hex Hole Bolt
$\phi 125$	11	22	5	33	55	M10
$\phi 160$	11	22	5	40	62	M10

TA Single Rod



Note 1) (A),(B),(C),(D) are the positioning relationships of the port, valve, etc.

Note 2) () in figure is the dimension for the cylinder with additional bellows.

Note 3) Please note that the cushion valve of $\phi 100$ to $\phi 160$ comes off when loosening it too much and drops.

TA Type Basic Table of Dimensions

[□ indicates no switch, switch adjusted specifications (up to $\phi 100$) are common ranges.]

Units:mm

Symbol Bore	Rod				D	TL	J	FL	TX	HX	I	Y	Z	DL	T	U	□A	□W	N	M	X	ϕV	RcG
	ϕB	C	E	F																			
$\phi 32$	16	24	39	M12 P1.25	15	103	58	110	34	11	10	38	25	29	7	M6 P1.0	44	33	44	76	R1	16	1/4
$\phi 40$	16	24	39	M12 P1.25	15	103	58	110	34	11	10	38	25	29	7	M6 P1.0	50	37	50	100	R1.6	25	3/8
$\phi 50$	22.4	36	51	M18 P1.5	15	103	58	110	34	11	10	38	25	29	7	M6 P1.0	62	47	63	113	R1.6	25	3/8
$\phi 63$	22.4	36	51	M18 P1.5	15	106	61	115	34	11	10	38	25	29	9	M8 P1.0	75	56	76	126	R1.6	25	3/8
$\phi 80$	28	48	67	M24 P2.0	19	124	67	134	43	14	16	45	32	38	10	M10 P1.25	94	70	95	145	R1.6	25	1/2
$\phi 100$	35.5	60	83	M30 P2.0	23	132	75	144	43	14	16	45	32	38	12	M12 P1.25	114	89	114	178	R2.5	32	1/2
$\phi 125$	45	84	109	M42 P2.0	25	136 (146)	75 (85)	152 (162)	47	14	20	45	32	42	16	M16 P1.5	138	110	144	216	R2.5	36	1/2
$\phi 160$	56	96	125	M48 P2.0	29	159	88	178	54	17	25	50	38	50	19	M20 P1.5	178	142	184	274	R3	45	3/4

Note1) The dimensions in () are special dimensions for switch adjusted specification.

Note2) Please refer to the S Type specifications on P.60 for the wrench-hold specifics (both sides).

TA Double Rod

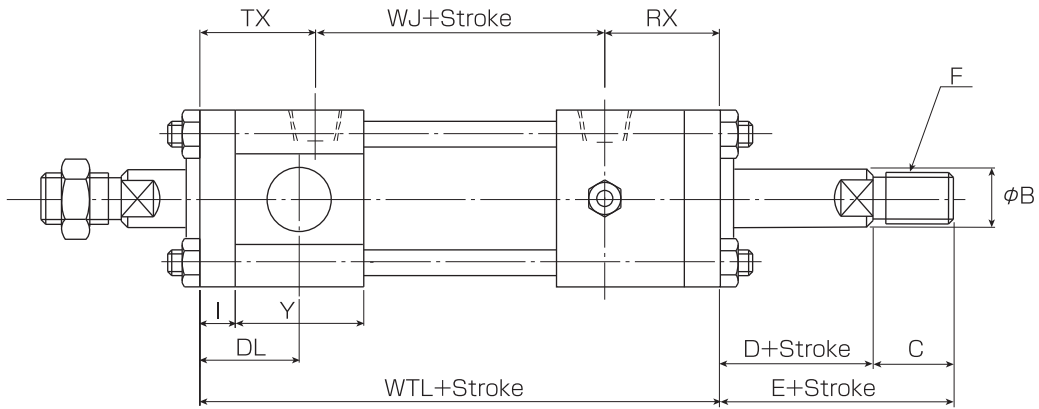

■ Double Rod Units:mm

Symbol Bore	WTL	WJ	RX
φ32	132	64	34
φ40	136	68	34
φ50	136	68	34
φ63	136	68	34
φ80	162	76	43
φ100	159	81	35
φ125	167 (190)	75 (98)	45
φ160	192	88	50

TC Single Rod

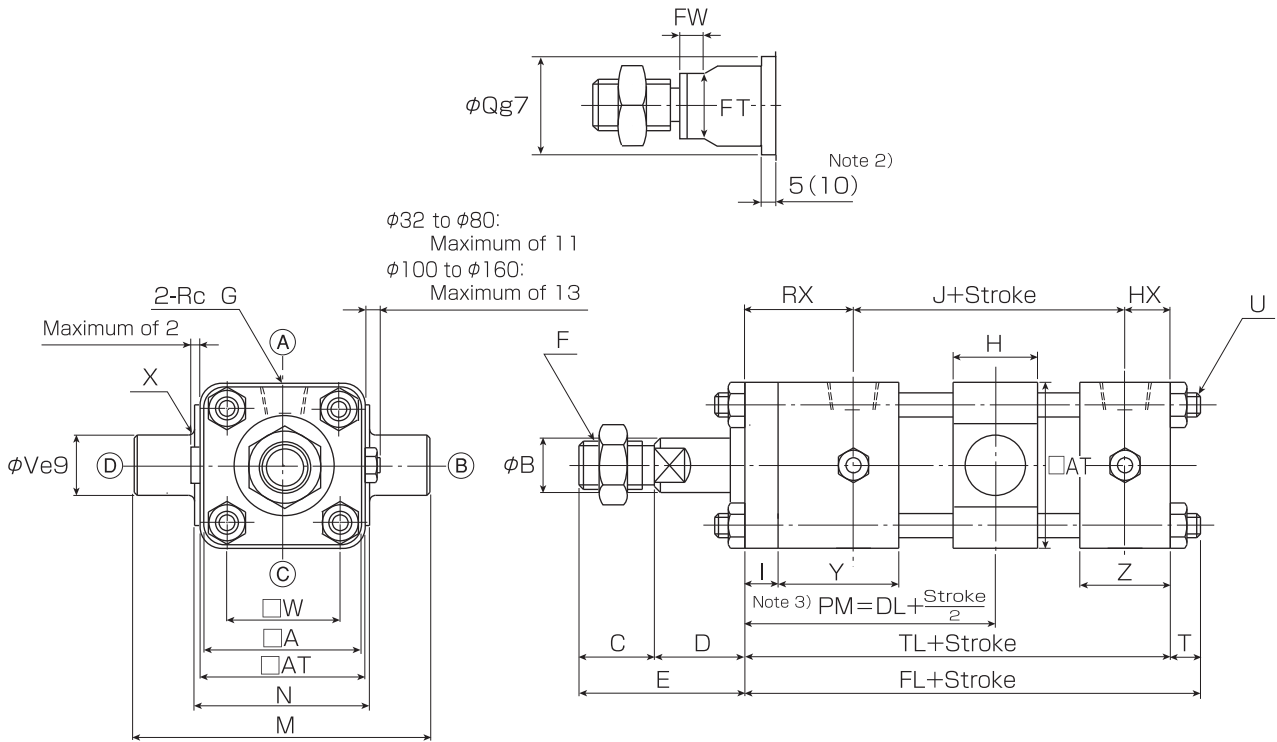

- Note 1) (A),(B),(C),(D) are the positioning relationships of the port, valve, etc.
 Note 2) () in figure is the dimension for the cylinder with additional bellows.
 Note 3) Please direct it separately when the size PM is different from the catalogue mark.
 Decimal digits of the PM dimension are omitted.
 Note 4) Please note that the cushion valve of $\phi 100$ to $\phi 160$ comes off when loosening it too much and drops.

TC Type Basic Table of Dimensions

[□ indicates no switch, switch adjusted specifications (up to $\phi 100$) are common ranges.]

Units:mm

Symbol Bore	Rod				D	TL	J	FL	DL	RX	HX	I	Y	Z	T	H	□AT	U	□A	□W	N	M	X	ϕV	RcG
	ϕB	C	E	F																					
$\phi 32$	16	24	39	M12 P1.25	15	103	58	110	63	34	11	10	38	25	7	30	52	M6 P1.0	44	33	55	87	R1	16	1/4
$\phi 40$	16	24	39	M12 P1.25	15	103	58	110	63	34	11	10	38	25	7	30	59	M6 P1.0	50	37	63	113	R1.6	25	3/8
$\phi 50$	22.4	36	51	M18 P1.5	15	103	58	110	63	34	11	10	38	25	7	30	71	M6 P1.0	62	47	76	126	R1.6	25	3/8
$\phi 63$	22.4	36	51	M18 P1.5	15	106	61	115	64.5	34	11	10	38	25	9	30	86	M8 P1.0	75	56	88	138	R1.6	25	3/8
$\phi 80$	28	48	67	M24 P2.0	19	124	67	134	76.5	43	14	16	45	32	10	35	104	M10 P1.25	94	70	114	164	R1.6	25	1/2
$\phi 100$	35.5	60	83	M30 P2.0	23	124	75	136	76.5	35	14	16	37	32	12	40	132	M12 P1.25	114	89	140	204	R2.5	32	1/2
$\phi 125$	45	84	109	M42 P2.0	25	134 (144)	75 (85)	150 (160)	83.5	45	14	20	43	32	16	53	160	M16 P1.5	138	110	166	238	R2.5	36	1/2
$\phi 160$	56	96	125	M48 P2.0	29	155	88	174	96	50	17	25	46	38	19	58	208	M20 P1.5	178	142	214	304	R3	45	3/4

- Note 1) The dimensions in () are special dimensions for switch adjusted specification.
 Note 2) Please refer to the S Type specifications on P.60 for the wrench-hold specifics (both sides).

TC Double Rod

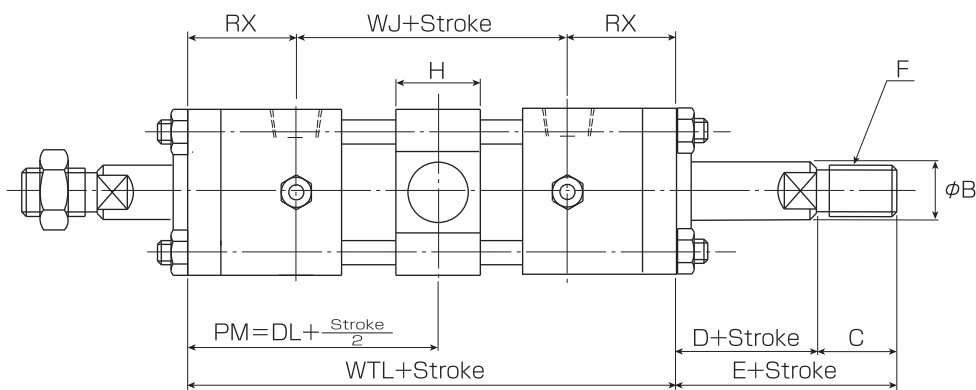

Double Rod

Units:mm

Symbol Bore	WTL	WJ
$\phi 32$	132	64
$\phi 40$	136	68
$\phi 50$	136	68
$\phi 63$	136	68
$\phi 80$	162	76
$\phi 100$	151	81
$\phi 125$	165 (188)	75 (98)
$\phi 160$	188	88

Single Protrusion End Joint : T type

Bore	Material
φ32 to φ160	Spheroidal Graphite Iron Casting

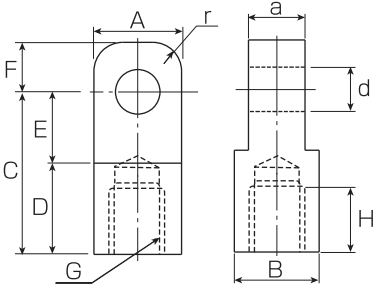

Single Protrusion End Joint Dimension Table

Units:mm

Symbol Bore	φd	C	a	A	B	D	E	F	r	H	G	Parts Code
φ32	12	55	16 ⁰ _{-0.1}	28	24	35	20	12	R8	25	M12 P1.25	TJ-K32
φ40	14	60	20 ⁰ _{-0.1}	28	24	40	20	12	R8	25	M12 P1.25	TJ-K40
φ50	14	64	20 ⁰ _{-0.1}	33	28	46	18	14	R10	37	M18 P1.5	TJ-K50
φ63	14	64	20 ⁰ _{-0.1}	33	28	46	18	14	R11	37	M18 P1.5	TJ-K63
φ80	20	100	32 ⁰ _{-0.1}	43	38	70	30	19	R12	49	M24 P2	TJ-K80
φ100	25	110	40 ⁰ _{-0.1}	53	48	73	37	24	R16	61	M30 P2	TJ-K100
φ125	32	132	45 ⁰ _{-0.1}	70	70	92	40	32	R20	67	M42 P2	TJ-K125
φ160	36	150	50 ⁰ _{-0.1}	79	79	105	45	36	R22	78	M48 P2	TJ-K160

Double Protrusion End Joint : Y type

Bore	Material
φ32 to φ100	Spheroidal Graphite Iron Casting
φ125 or φ160	Rolled Steels for General structure

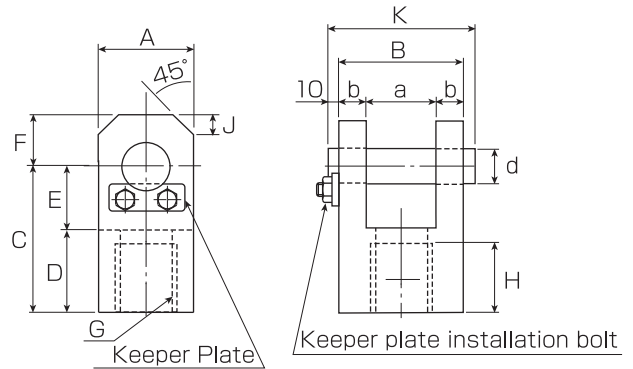
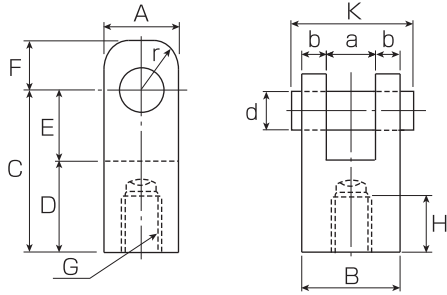

φ32 to φ100

φ125 or φ160

Note) For up to φ100, a split pin is used to fasten the pin.

Note) Pins are inserted with Y joint Up to φ125 to φ160.

Double Protrusion End Joint Dimension Table

Units:mm

Symbol Bore	φd	C	a	b	A	B	D	E	F	r	H	G	K	J	Parts Code
φ32	12	55	16 ^{+1.5} _{+0.5}	8	24	32	35	20	12	R8	25	M12 P1.25	46	—	YJ-K32
φ40	14	60	20 ^{+1.5} _{+0.5}	12	24	44	40	20	12	R8	25	M12 P1.25	58	—	YJ-K40
φ50	14	64	20 ^{+1.5} _{+0.5}	12	28	44	46	18	14	R10	37	M18 P1.5	58	—	YJ-K50
φ63	14	64	20 ^{+1.5} _{+0.5}	12	28	44	46	18	14	R10	37	M18 P1.5	58	—	YJ-K63
φ80	20	100	32 ^{+1.5} _{+0.5}	16	38	64	72	28	19	R12	49	M24 P2	78	—	YJ-K80
φ100	25	110	40 ^{+1.5} _{+0.5}	20	48	80	75	35	24	R16	61	M30 P2	94	—	YJ-K100
φ125	32	132	45 ^{+1.5} _{+0.5}	22.5	65	90	92	40	35	—	75	M42 P2	105	15	YJ-K125
φ160	36	150	50 ^{+1.5} _{+0.5}	25	70	100	105	45	40	—	86	M48 P2	115	15	YJ-K160

Bellows

- J : (Material: Neoprene, Heat Resistant : 100℃)
- JC : (Material: Conex, Heat Resistant : 220℃)
- JS : (Material: Silicon Glass Cloth, Heat Resistant : 220℃)
- JA : (Material: Aluminum Leaf Glass Cloth, Heat Resistant : 350℃)

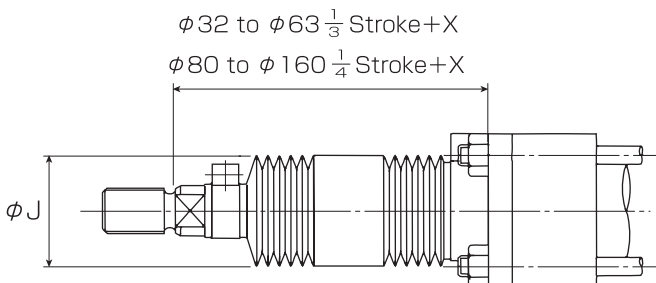

Table of Dimensions

Units:mm

Symbol Bore	J		X
	5 to 49	from 50	
φ32	45	36	50
φ40	45	40	50
φ50	55	45	55
φ63	55	45	55
φ80	65	60	65
φ100	80	71	65
φ125	80	80	65
φ160	100	100	70

- Note 1) With the cylinder with bellows, the bush protrusion length is different from that of the standard cylinder.
- Note 2) The numbers under "J" indicate the Stroke.
- Note 3) Less than 5-strokes cannot be manufactured.
- Note 4) Bellows is sent out after installing it on the cylinder.
- Note 5) As for cylinders originally equipped with bellows, please specify the serial number or dimension D (in the illustration below) when ordering a replacement without the bellows.

■FK Connector

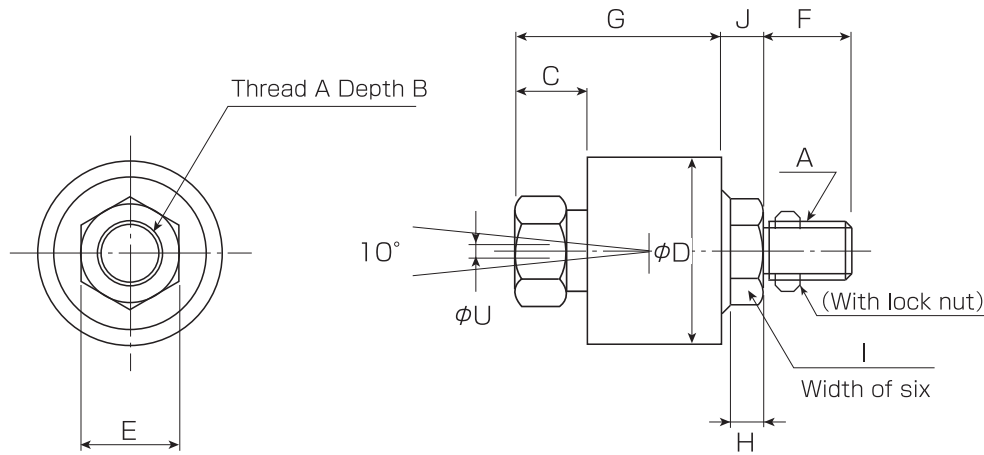

※The FK connector cannot be used for some types of cylinders at the full output under the nominal pressure. Please check the load being used in advance.

■Table of Dimensions

Units:mm

Symbol Bore	Parts Code	A	B	C	D	E	F	G	H	I	J	U	Usage loads (N)		Mass (kg)
													Pull	Push	
φ32	FK-12	M12P1.25	13	17 ±1.0	45	23	24	52 ±1.0	6	23	6	2	up to 2110	up to 2810	0.40
φ40													up to 3690	up to 4400	
φ50	FK-18	M18P1.5	15	27 ±1.0	45	29	24	62 ±1.0	6	23	6	2	up to 5290	up to 6870	0.50
φ63													up to 5290	up to 10910	
φ80	FK-24	M24P2.0	22	34.5±1.0	61	35	32	78 ±1.0	6	29	11.5	3	up to 7640	up to 17590	1.10
φ100	FK-30	M30P2.0	22	36.5±1.0	69	41	42	88.5±1.0	8	35	15	3	up to 13520	up to 27490	1.80

Note 1) It is possible to turn the thread section; however, it is not a joint for rotation so it cannot be used for turning.

Note 2) Supplying oil is unnecessary and grease lubricant is used to fill it.

Note 3) Cannot be reused after disassembly.

Note 4) The usage loads in the Table of Dimensions are values from static load tests.

Note 5) In the case of loads where there are repeated shocks, the usage load value will decrease, so this should be taken into consideration.

Note 6) The one of inside diameter φ125 and φ160 cannot be produced.

Lock Nut

Bore	Material
φ32 to φ160	Rolled Steels for General Structure

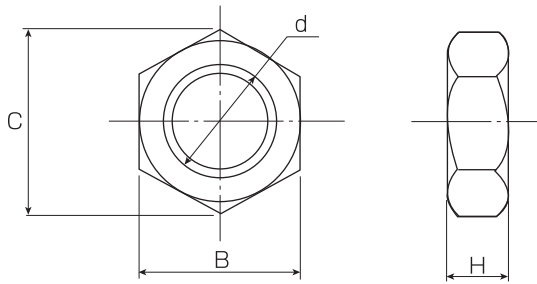

Table of Dimensions

Units:mm

Symbol Bore	d	H	B	C	Parts Code
φ32	M12 P1.25	7	19	21.9	LN-K32
φ40	M12 P1.25	7	19	21.9	LN-K40
φ50	M18 P1.5	11	27	31.2	LN-K50
φ63	M18 P1.5	11	27	31.2	LN-K63
φ80	M24 P2	14	36	41.6	LN-K80
φ100	M30 P2	17	46	53.1	LN-K100
φ125	M42 P2	22	66	75	LN-K125
φ160	M48 P2	26	75	86.5	LN-K160

Pin

Bore	Material
φ32 to φ250	Carbon Steels for Machine Structural Use

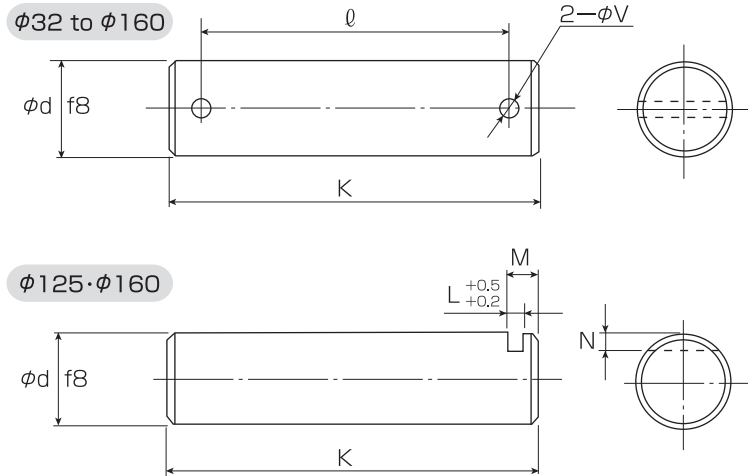

Table of Dimensions

Units:mm

Symbol Bore	φd	L	M	N	K	V	ℓ
φ32	12	—	—	—	46	2.5	38
φ40	14	—	—	—	58	2.5	50
φ50	14	—	—	—	58(66)	2.5	50(58)
φ63	14	—	—	—	58(66)	2.5	50(58)
φ80	20	—	—	—	78	2.5	70
φ100	25	—	—	—	94	2.5	86
φ125	32	5	10	5.5	105	—	—
φ160	36	5	10	5.5	115	—	—

Note) The dimensions in () apply to the CB series.

Keeper Plate

Bore	Material
φ125 to φ160	Rolled Steels for General Structure

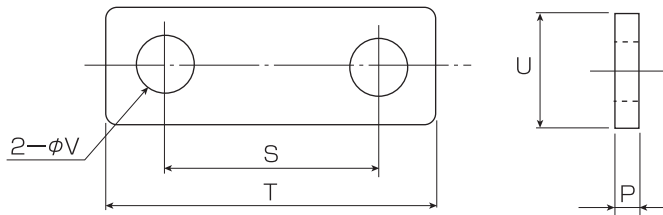

Table of Dimensions

Units:mm

Symbol Bore	V	U	P	S	T	With Hex Hole Bolt
φ125	11	22	5	33	55	M10
φ160	11	22	5	40	62	M10

Mass Table

Units: kg

Symbol Bore	Basic Mass (Stroke: 0mm)									Stroke Mass per 100mm
	S	LA	LB	FA	FB	CA	CB	TC	TA	
φ32	1.2	1.4	1.4	1.4	1.5	1.4	1.4	1.6	1.5	0.41
φ40	1.8	2.1	2.1	2.1	2.2	2.0	2.0	2.5	2.3	0.45
φ50	2.6	3.1	3.0	3.0	3.1	2.9	2.9	3.6	2.2	0.78
φ63	3.9	4.3	4.4	4.5	4.6	4.3	4.3	5.4	4.6	0.94
φ80	7.5	8.4	8.5	9.0	9.2	8.6	8.5	10.0	8.8	1.22
φ100	11.4	12.6	13.0	13.4	13.7	12.7	12.8	15.1	14.5	2.00
φ125	18.6	20.4	20.9	22.4	22.9	22.8	23.0	24.3	23.4	3.30
φ160	35.1	38.4	40.8	42.9	43.9	43.2	44.1	46.1	41.2	4.90

Calculation example Mounting:FB, Bore of cylinder:φ100, Stroke:350mm
 $13.7+2.00 \times 3.5=20.7\text{kg}$

End Joint Mass Table

Units: kg

Bore	Single Protrusion End Joint	Double Protrusion End Joint	Lock Nut
φ32	0.26	0.27	0.01
φ40	0.31	0.43	0.01
φ50	0.40	0.51	0.03
φ63	0.40	0.51	0.03
φ80	1.17	1.57	0.07
φ100	1.74	2.66	0.16
φ125	5.29	6.57	0.44
φ160	6.15	8.82	0.67



บริษัท นานดีอินเตอร์เทรด จำกัด
NANDEE INTER-TRADE CO., LTD.

314, 316, 318, 320, 322 ซอยจันทน์ 32 ถนนจันทน์ แขวงทุ่งวัดดอน เขตสาทร กทม. 10120
Tel : 0-2675-8230 (Auto), 0-2675-8240 (Auto) Fax : 0-2212-1448, 0-2213-0360

LINE : @nandeeintertrade
f : nandeeintertrade
✉ : info@nandee.co.th
🌐 : www.nandee.co.th

LINE @

