



OIL COOLING UNIT

Immersion type for coolant cooling

AKJ18A, AKJ35A, AKJ45A, AKJ56A, AKJ90A



**High-accuracy,
Energy-saving, Lightweight
Transformerless 400 V
specifications now
available with immersion type
for coolant cooling
Suited to all applications!**

I N D E X

Features/ Applications	Pages 1 and 2
System Overview/ Piping System Diagram	P3
Nomenclature	P4
Specifications/ Operating range	Pages 5 and 6
Cooling Capacity Characteristic Chart	Pages 7 and 8
External Dimension Diagram	Pages 9 to 11
Installation Dimension Diagram	P12

Optional Parts

Thermistor	P13
Option Board for Communication	P14

Supplementary Information

Control Panel/ Operation Mode and Setting Method	Pages 15 to 16
Electric Wiring Diagram	P17
Electric Wiring Connection Instruction	P18
Notes for Handling	Pages 19 to 20
Method of Selection	P21
Long Life Filter	P22



NEW

Immersion type for coolant cooling

Oil Cooling Unit 10 Series

DAIKIN INDUSTRIES, LTD.
Oil Hydraulic Division
Oil Hydraulic Equipment

For Coolant Cooling | Immersion type |

AKJ18A, AKJ35A, AKJ45A
AKJ56A, AKJ90A



Features

Immersion-type oil cooling unit mounted directly on the coolant tank

It is a cooler that is placed on the coolant tank and cools the fluid inside the tank directly with a cooling coil.

* The circulation pump is not provided as an accessory and must be prepared separately by the customer.

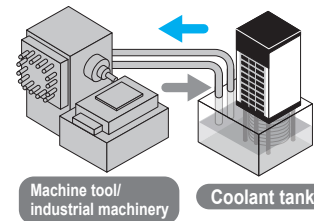

Acclaimed high-accuracy temperature control

- Acclaimed high-accuracy $\pm 0.1^{\circ}\text{C}$ fluid temperature control
- The cooling capacity resolution in the low-load range has been improved by optimal control of the compressor/inverter and electronic expansion valve.
- Fluid temperature control of $\pm 0.1^{\circ}\text{C}$ has been realized over a load range from 0% (no load) to 100%.

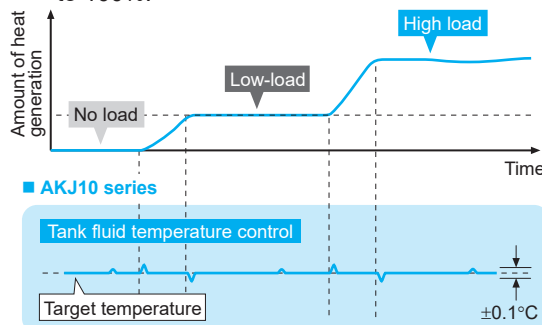

Note: Pattern diagram with the heating load stabilized at 0 - 100%

Reduced environmental load

- Complies with environmental regulations, e.g. by adopting printed circuit boards with lead-free solder.

Lightweight transformerless 400 V specifications now available

* Comparison of AKJ459-047 and AKJ45A-500

- The dimensions are the same as standard models, so no design changes are needed for different voltages.
- The mass is much lower than that of the 9 Series. (27% reduction)

Achieves high energy-saving performance

- Achieve high energy-saving performance with the adoption of a DAIKIN original IPM motor and inverter.
- The power consumption can be checked on the control panel.

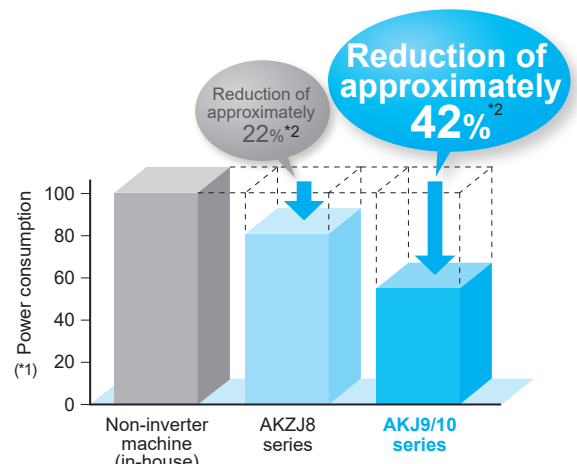

*1. The comparison reduction costs are based on a Daikin non-inverter system and are shown as 100% consumption.

*2. Measured during the operation patterns for DAIKIN models

Features

Reliable in challenging factory environments

- The control panel ingress protection is equivalent to an IP54 rating.
- Electronic components resistant to sulfidation have been incorporated.
- The specifications for withstanding vibration during transport are matched to actual situations.
- The cooling coil construction suppresses the adhesion and accumulation of cutting/grinding chips.

Offering 5 types of standard option models in addition to the standard model to achieve short delivery

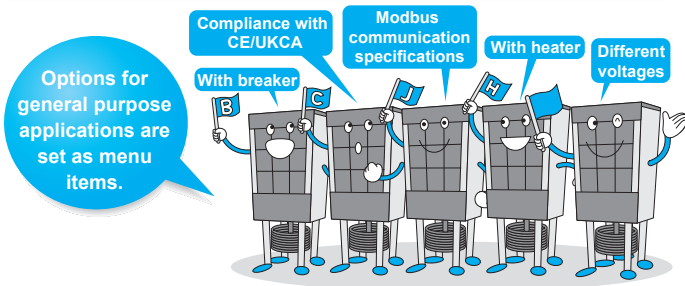

Simple monitoring of the operating status

- The room temperature, tank fluid temperature and other internal data can be monitored at a personal computer using Hybrid-Win*.
- Operating status can be grasped easily with one list presenting all the data collectively.

* Hybrid-Win is utility software to monitor the internal status of DAIKIN hybrid systems using a PC. The software and its instruction manual can be downloaded from the website "https://www.hyd.daikin.com" free of charge by completing the user registration process.

* The communications cable and the monitor harness must be purchased separately.

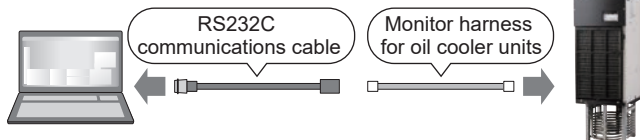

Superior functionality remains unchanged

- **Refrigerant gas shortage detection function**
When the refrigerant gas leak status occurs (cooling disabled), alarm signals are output. Prevents damage to the machine and machining defects.
- **Temperature warning function**
A warning signal can be output when the targeted fluid temperature or room temperature is out of the user-selected range.
- **Autotuning function**
An autotuning function that automatically sets the control gain according to the system installed (tank oil volume, piping, etc.) greatly reduces adjustment time at the trial run.
- **999-hour timer function (ON timer)**
The operation start time can be set in a range between 0 and 999 hours (in hour units).
- **Predictive maintenance function**
 - A warning signal is output to notify that maintenance is required when the air filter or condenser becomes clogged.
 - When a thermistor fault (control failure) occurs, emergency operation is possible using another operation mode. This minimizes effects due to line stoppages.

Easy to operate, and easy to maintain

- Easy-to-operate control panel that shows power consumption
- Plug-in terminal block makes tools unnecessary when connecting signals.
- Air filter structure that resists condenser clogging due to oil mist

A strong ally for troubled customers

Installing Long Life Filters makes maintenance simple

When a Long Life Filter is installed, the cooling fins do not become clogged and no cleaning is required. You are recommended to install a Long Life Filter when your unit is new.

For details, refer to page 22.

Applications

Example of major applications

Machine tools: Machining centers, NC lathes, grinding machines, NC specialized machines, NC electric discharge machines, etc.
Industrial machine: Molding machine, press, etc.

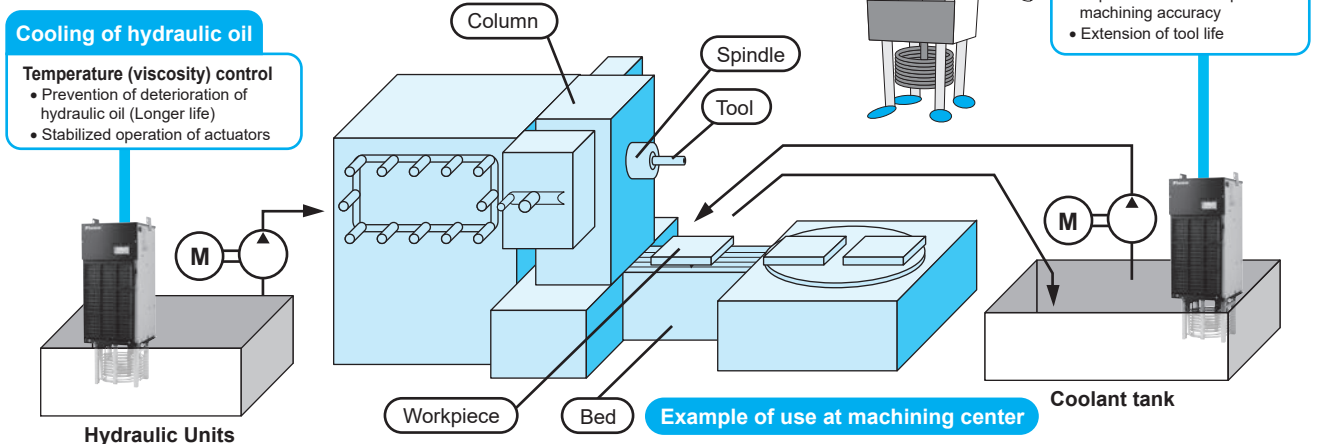

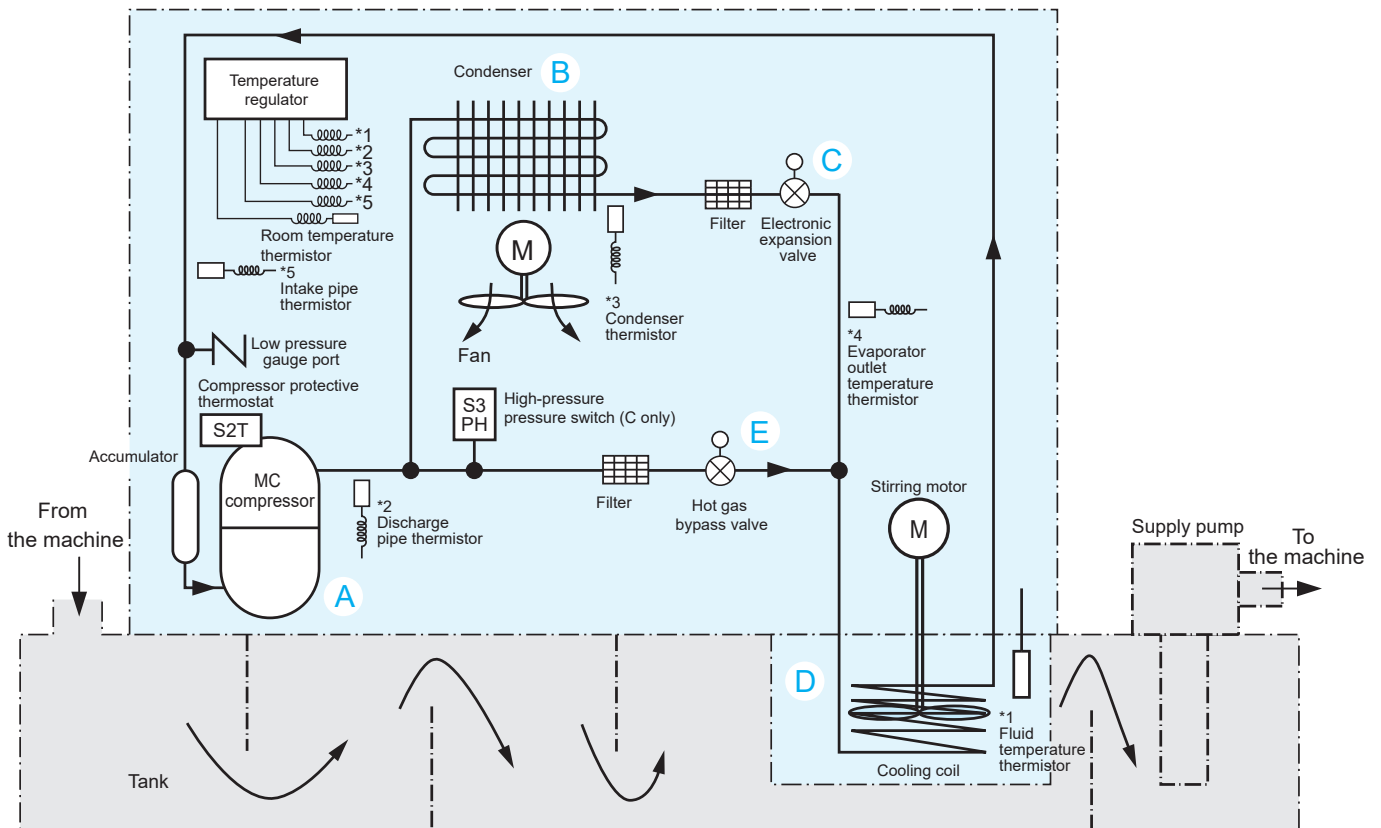

Note: 1. The [] enclosure indicates work that needs to be arranged locally.
 2. The heater is only applicable to AKJ-H.

■ Refrigerating cycle

- A : Refrigerant gas is converted into compressed gas at high temperature and high pressure by a compressor so that gas can be easily cooled and liquefied by a condenser.
- B : In the condenser, the gas at high temperature and high pressure generated in the compressor is cooled with air and converted into liquid at high temperature and high pressure.
- C : The decompression mechanism (electronic expansion valve) reduces the pressure of the liquid at high temperature and high pressure and converts it into liquid at low temperature and low pressure by throttling it so that it can be easily evaporated in a cooling coil.
- D : In the cooling coil, liquid at low temperature and low pressure generated in the decompression mechanism absorbs heat from the coolant, evaporates (cools the coolant), and is converted into gas at low temperature and low pressure.
- E : The hot gas bypass valve controls the cooling capacity at low loads by adjusting the volume of gas at high temperature and high pressure supplied to the cooling coil.

OIL COOLING UNIT



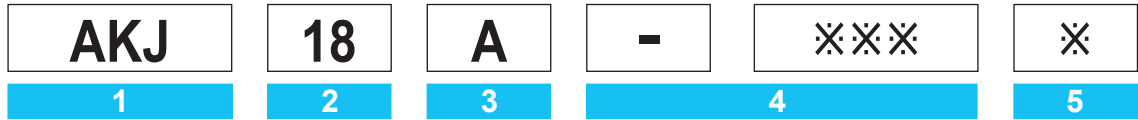

1 Oil cooling unit identification code

AKJ: High-accuracy inverter controlled oil cooling unit
Immersion type for cutting/grinding fluid (oil)

2 Cooling capacity (kW)

18: 1.8 kW
35: 3.5 kW
45: 4.5 kW
56: 5.6 kW
90: 9.0 kW

3 Symbol of series (Symbol to represent model change)

A: 10 series

4 Symbol of option type/Non-standard number

Options and their combinations (Refer to the following table.)

Special specifications

-※※※(3-digit number), C※※※(3-digit number), etc.
Please consult us separately.
-500 indicates standard specifications (380 V/400 V/415 V)

5 Special specifications (specified packing specifications, communication options, etc.)

J: Communications option
RS485/Modbus protocol

Options and their combinations

■AKJ10 (Immersion type)

Option symbol	With breaker	Compliance with CE/UKCA	With heater	Different voltage (1)	Different voltage (2)	Different voltage (3)
-B	○	-	-	-	-	-
-C	-	○	-	-	-	-
-H	-	-	○	-	-	-
-046	-	-	-	○	-	-
-500	-	-	-	-	○	-
-048	○	-	-	-	-	○
-BC	○	○	-	-	-	-
-BH	○	-	○	-	-	-
-CH	-	○	○	-	-	-
-BCH	○	○	○	-	-	-
-001	○	-	-	○	-	-
-002	-	○	-	○	-	-
-003	-	-	○	○	-	-
-005	○	○	-	○	-	-
-006	○	-	○	○	-	-
-008	-	○	○	○	-	-
-011	○	○	○	○	-	-

Option symbol	With breaker	Compliance with CE/UKCA	With heater	Different voltage (1)	Different voltage (2)	Different voltage (3)
B500	○	-	-	-	○	-
C500	-	○	-	-	○	-
H500	-	-	○	-	○	-
D500	○	○	-	-	○	-
E500	○	-	○	-	○	-
K500	-	○	○	-	○	-
P500	○	○	○	-	○	-
-032	○	○	-	-	-	○
-033	○	-	○	-	-	○
-038	○	○	○	-	-	○

AKJ18A AKJ35A AKJ45A

Oil cooling unit horsepower (HP)	0.5					1.2					1.5									
	AKJ18A					AKJ35A					AKJ45A									
Model name	Standard	-B	-C	-J	-H	Different voltage specifications ¹	Standard	-B	-C	-J	-H	Different voltage specifications ¹	Standard	-B	-C	-J	-H	Different voltage specifications ¹		
Cooling capacity (50/60 Hz) ¹ kW	1.6/1.8						3.2/3.5						4.2/4.5							
Heater (at 200 V) kW	1						1						1							
Supply power ²	3-phase 200/200, 220 V 50/60 Hz					*3	3-phase 200/200, 220 V 50/60 Hz					*3	3-phase 200/200, 220 V 50/60 Hz					*3		
Circuit voltage	Main circuit ³																			
	Operating circuit																			
Max. power consumption	When cooling	DC12/24 V																		
		200 V 50 Hz	0.82 kW/3.3 A					*10	1.37 kW/5.2 A					*10	1.46 kW/5.6 A					
		200 V 60 Hz	0.83 kW/3.2 A						1.38 kW/5.1 A						1.48 kW/5.4 A					
		220 V 60 Hz	0.83 kW/3.0 A						1.39 kW/4.8 A						1.48 kW/5.1 A					
Max. current consumption	When heating	200 V 50 Hz	1.20 kW/3.8 A						1.20 kW/3.8 A						1.20 kW/3.8 A					
		200 V 60 Hz	1.20 kW/3.8 A						1.20 kW/3.8 A						1.20 kW/3.8 A					
		220 V 60 Hz	1.44 kW/4.2 A						1.44 kW/4.2 A						1.44 kW/4.2 A					
Transformer capacity	1.70 kVA						1.70 kVA						1.70 kVA							
Exterior color	Ivory white																			
External dimensions (H × W × D) mm	920 × 360 × 440						1,045 × 360 × 440						1,200 × 360 × 440							
Compressor (Hermetic DC swing type)	Equivalent to 0.4 kW						Equivalent to 0.75 kW						Equivalent to 1.1 kW							
Evaporator	Open coil type																			
Condenser	Cross-fin coil type																			
Fan Motor	54 W																			
Agitator Motor	3φ, 60 W, 4P																			
Temperature control (Selectable)	Synchronization type	Room temperature or machine temperature ⁴ (Set to "Room temperature: Mode 3" by default)																		
		Object to be controlled	Tank fluid temperature																	
		Synchronization range-°C	-9.9 to +9.9 against the standard temperature (Set at 0.0 by default)																	
		Object to be controlled	Tank fluid temperature																	
Fixed type	Object to be controlled	Tank fluid temperature																		
	Range °C	5 to 50																		
Refrigerant control	Rotation speed control of compressor by inverter + Opening rate control of electronic expansion valve																			
Refrigerant: R410A (GWP: 2090) ⁵	Filling amount kg	0.62						0.88						0.93						
	Carbon dioxide equivalent tCO ₂ e _{eq}	1.30						1.84						1.95						
Protection devices	Agitator internal thermostat, reverse-phase protection device, restart prevention timer, low room temperature protection thermistor, high fluid temperature protection thermistor, low fluid temperature protection thermistor, discharge pipe thermistor, condenser thermistor, refrigerant leakage detection, set of inverter protection devices, high-pressure pressure switch (C type only), compressor thermal protector, overheat protection temperature switch (H type only), temperature fuse (H type only), circuit breaker (B type only)																			
Operating range	Room temperature °C	5 to 45																		
	Tank fluid temperature °C	5 to 50																		
	Oil viscosity mm ² /s	0.5 to 200																		
Acceptable oils	Water-soluble cutting/grinding fluid, cutting/grinding oil, lubrication oil, hydraulic oil, industrial water (Cannot be used for drugs, food products, and fuel)																			
Noise level (value equivalent to measurement in an anechoic chamber) (Front 1 m, height 1.55 m) dB (A) ⁷	62																			
Permissible transport vibration ⁸	Up and down vibration 14.7 m/s ² × 2.5 hr (7.5 to 100 Hz sweep/five min.)																			
Ingress protection	IP2X ⁶																			
Mass kg	43					45	67 ³	50					74 ³	52					54	76 ³
In-machine circuit breaker (rated current) A	10						10						10							
Items prepared by the customer	Earth leakage breaker (Rated current) ⁹ A	10																		
	Device other than earth leakage breaker	Tank, supply pump, float switch, return filter																		

Note: *1. The cooling capacity indicates the value at the standard point (tank fluid temperature: 35°C, room temperature: 35°C, oil used: ISO VG32, 1 atm). This unit has about ±5% of product tolerance.

*2. Use a commercial power supply for the power source. The use of an inverter power supply may cause burn damage to the oil cooling unit. The voltage fluctuation range should be within ±10%. If it is more than ±10%, please consult us.

*3. There are three types of different voltage specifications depending on the power source: -046, -500 and -048 units. -046 units have no transformer and therefore have the same external dimensions and mass as standard units. Their main circuit voltage is AC 220/230 V, 50/60 Hz.

-500 units have no transformer and therefore have the same external dimensions and mass as standard units. Their main circuit voltage is AC 380/400/415 V, 50/60 Hz.

-048 units have a transformer and therefore have a different mass than the standard units. Their main circuit voltage is the transformer's secondary side voltage of AC 200 V, 50/60 Hz.

*4. The machine temperature synchronization thermistor available as an option is required for this function. (Refer to Page 13 for details.)

*5. The refrigerant is enclosed in a sealed container. The SDS (Safety Data Sheet) for R410A refrigerant is provided with to -C type units.

*6. Electric component section ingress protection: IP54 or equivalent (However, use piping conduits etc. rated at least IP54 at wiring ports.)

*7. The rotational speed of the fan motor varies depending on the room temperature to conserve energy. Therefore, it is normal for the noise level to vary accordingly.

*8. The specifications for permissible transport vibration are those of a standard unit.

*9. The earth leakage breaker is not supplied with this product. Please prepare it yourself.

*10. The maximum power consumption/maximum current consumption of different voltage specifications are shown in the tables below.

AKJ18A		AKJ35A		AKJ45A		AKJ56A		AKJ90A	
Supply power	Power/current	Supply power	Power/current	Supply power	Power/current	Supply power	Power/current	Supply power	Power/current
220 V	0.83 kW/ 3.0 A	220 V	1.39 kW/ 4.8 A	220 V	1.48 kW/ 5.1 A	220 V	2.92 kW/ 9.0 A	220 V	3.43 kW/ 10.3 A
230 V	0.83 kW/ 3.0 A	230 V	1.39 kW/ 4.6 A	230 V	1.48 kW/ 4.9 A	230 V	2.92 kW/ 8.6 A	230 V	3.44 kW/ 9.9 A
380 V	0.86 kW/ 1.9 A	380 V	1.43 kW/ 2.9 A	380 V	1.54 kW/ 3.2 A	380 V	2.89 kW/ 5.2 A	380 V	3.86 kW/ 8.1 A
400 V	0.87 kW/ 1.8 A	400 V	1.44 kW/ 2.8 A	400 V	1.56 kW/ 3.1 A	400 V	2.90 kW/ 5.1 A	400 V	3.87 kW/ 7.8 A
415 V	0.87 kW/ 1.8 A	415 V	1.44 kW/ 2.7 A	415 V	1.56 kW/ 3.0 A	415 V	2.91 kW/ 5.0 A	415 V	3.88 kW/ 7.6 A
440 V	0.83 kW/ 1.8 A	440 V	1.38 kW/ 2.4 A	440 V	1.48 kW/ 2.6 A	440 V	2.77 kW/ 4.3 A	440 V	3.43 kW/ 4.9 A
460 V	0.83 kW/ 1.5 A	460 V	1.38 kW/ 2.3 A	460 V	1.48 kW/ 2.5 A	460 V	2.77 kW/ 4.1 A	460 V	3.43 kW/ 4.7 A
480 V	0.83 kW/ 1.4 A	480 V	1.38 kW/ 2.2 A	480 V	1.48 kW/ 2.4 A	480 V	2.77 kW/ 3.9 A	480 V	3.43 kW/ 4.5 A

AKJ56A
AKJ90A

Oil cooling unit horsepower (HP)		2.0					3.0						
Model name		AKJ56A					AKJ90A						
		Standard	-B	-C	-J	-H	Different voltage specifications ¹⁾	Standard	-B	-C	-J	-H	Different voltage specifications ¹⁾
Cooling capacity (50/60 Hz) ¹⁾ kW		5.0/5.6					8.0/9.0						
Heater (at 200 V) kW		2					3						
Supply power ²⁾		3-phase 200/200, 220 V 50/60 Hz					*3						
Circuit voltage		Main circuit ³⁾					3-phase 200/200, 220 V 50/60 Hz						
		Operating circuit					DC12/24 V						
Max. power consumption	When cooling	200 V 50 Hz		2.77 kW/9.4 A			*10	200 V 50 Hz		3.38 kW/10.8 A			
		200 V 60 Hz		2.72 kW/9.2 A				200 V 60 Hz		3.43 kW/10.7 A			
		220 V 60 Hz		2.83 kW/8.9 A				220 V 60 Hz		3.43 kW/10.2 A			
Max. current consumption	When heating	200 V 50 Hz		2.32 kW/7.1 A			-	200 V 50 Hz		4.42 kW/13.1 A			
		200 V 60 Hz		2.33 kW/7.1 A			-	200 V 60 Hz		4.45 kW/13.1 A			
		220 V 60 Hz		2.79 kW/7.8 A			-	220 V 60 Hz		5.33 kW/14.4 A			
Transformer capacity		-					3.60 kVA		-			5.02 kVA	
Exterior color		Ivory white											
External dimensions (H x W x D) mm		1,440 x 470 x 500					1,615 x 560 x 620						
Compressor (Hermetic DC swing type)		Equivalent to 1.5 kW					Equivalent to 2.2 kW						
Evaporator		Open coil type											
Condenser		Cross-fin coil type											
Fan Motor		100 W											
Agitator Motor		3φ, 60 W, 4P											
Temperature control (Selectable)	Synchronization type	Standard		Room temperature or machine temperature ⁴⁾ (Set to "Room temperature: Mode 3" by default)									
		Object to be controlled		Tank fluid temperature									
	Synchronization range °C		-9.9 to +9.9 against the standard temperature (Set at 0.0 by default)										
	Fixed type	Object to be controlled		Tank fluid temperature									
Range °C		5 to 50											
Refrigerant control		Rotation speed control of compressor by inverter + Opening rate control of electronic expansion valve											
Refrigerant: R410A (GWP: 2090) ⁵⁾	Filling amount kg	Carbon dioxide equivalent tCO ₂ eq		1.07			2.24		1.56			3.27	
		Agitator internal thermostat, reverse-phase protection device, restart prevention timer, low room temperature protection thermistor, high fluid temperature protection thermistor, low fluid temperature protection thermistor, discharge pipe thermistor, condenser thermistor, refrigerant leakage detection, set of inverter protection devices, high-pressure pressure switch (C type only), compressor thermal protector, overheat protection temperature switch (H type only), temperature fuse (H type only), circuit breaker (B type only)											
Operating range	Room temperature °C		5 to 45										
	Tank fluid temperature °C		5 to 50										
	Oil viscosity mm ² /s		0.5 to 200										
Acceptable oils		Water-soluble cutting/grinding fluid, cutting/grinding oil, lubrication oil, hydraulic oil, industrial water (Cannot be used for drugs, food products, and fuel)											
Noise level (value equivalent to measurement in an anechoic chamber) (Front 1 m, height 1.55 m) dB (A) ⁷⁾		65					68						
Permissible transport vibration ⁸⁾		Up and down vibration 14.7 m/s ² x 2.5 hr (7.5 to 100 Hz sweep/five min.)											
Ingress protection		IP2X ⁶⁾											
Mass kg		76			79		101 ³⁾		96		100		124 ³⁾
In-machine circuit breaker (rated current) A		-		15		-		-		20		-	
Items prepared by the customer	Earth leakage breaker (Rated current) ⁹⁾ A		15					20					
	Device other than earth leakage breaker		Tank, supply pump, float switch, return filter										

Refer to Page 5 for explanatory notes.

Specifications / Operating range

Operating temperature range

- Note: 1. The "⊙" symbol indicates the standard point.
 2. Be sure to use the unit within the range of use specified in .
 (Use outside this range may cause unit failure.)

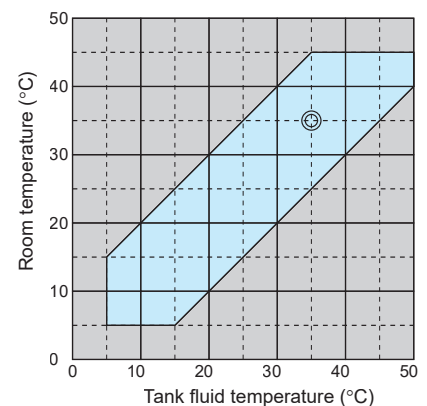

Cooling Capacity Characteristic Chart

AKJ18A

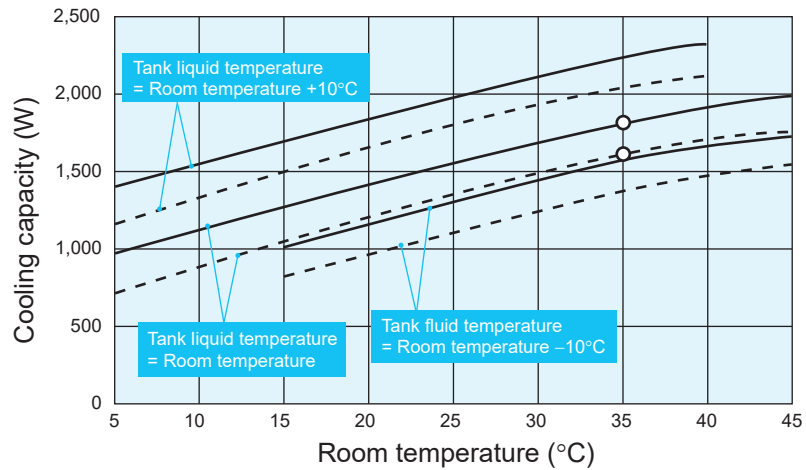

AKJ35A

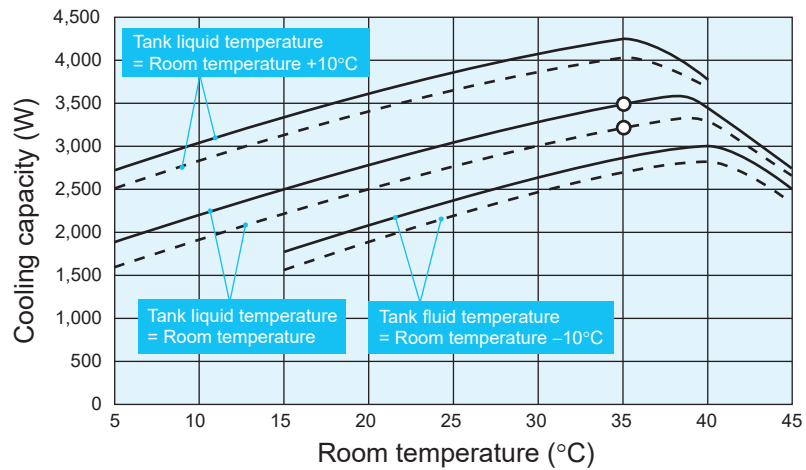

AKJ45A

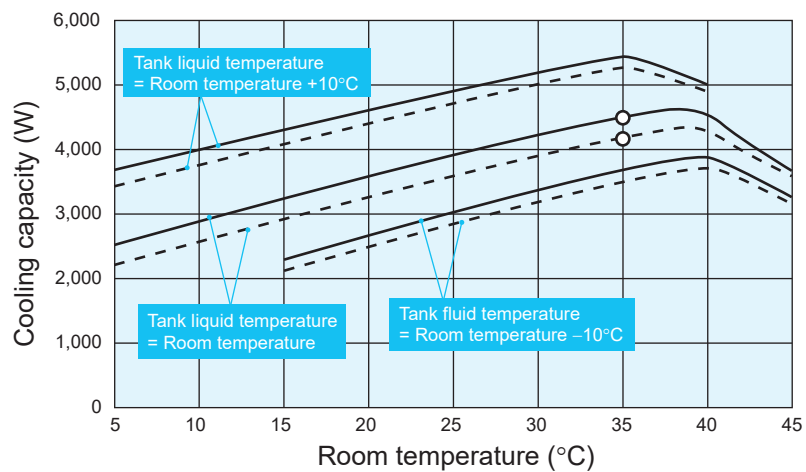

AKJ56A

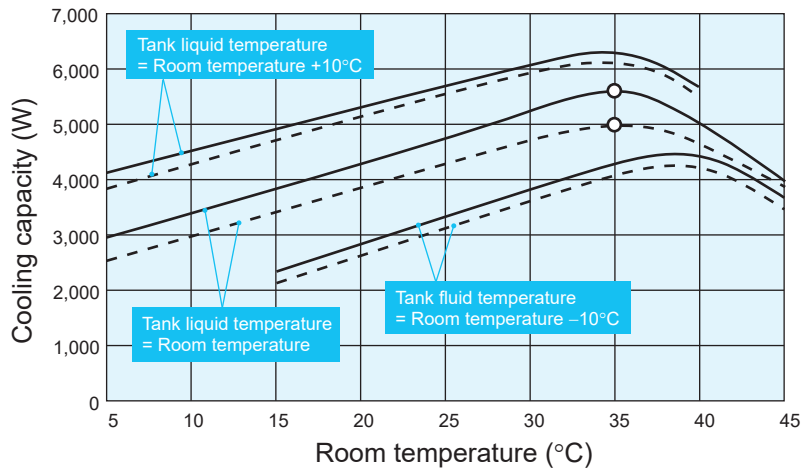

AKJ90A

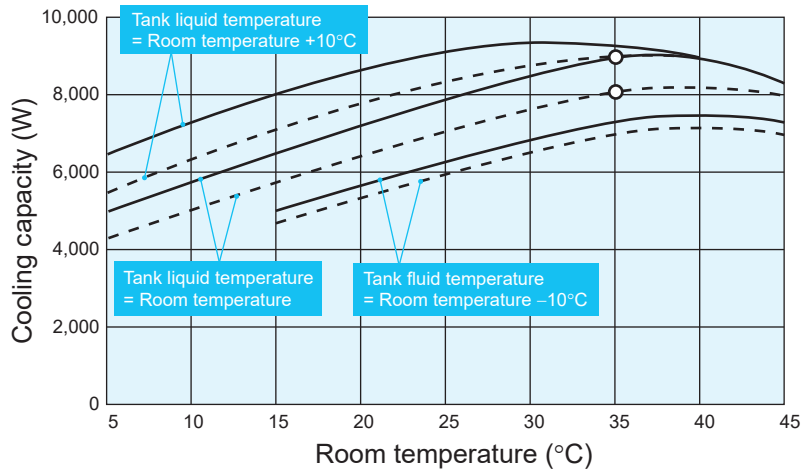

- Solid line — : When operated at 60 Hz ■ Broken line - - - : When operated at 50 Hz
1. The mark "O" shows the standard point. (Room temperature: 35°C, Tank fluid temperature: 35°C, Oil used: ISO VG32, 1 atm)
 2. The cooling capacity varies depending on conditions including the room temperature, tank fluid temperature and the kinematic viscosity of the oil, etc.

External Dimension Diagram

Note: Refer to Pages 5 and 6 for more details.
 • For the machining dimensions of the holes for installation on the tank, refer to page 12.

The positions of the bolt holes used for installing the product on the tank top plate are compatible with the 9 Series, but the positions of the power supply/signal cable inlet ports may be different.

AKJ18A (-B, -C, -H, -046, -048, -500)

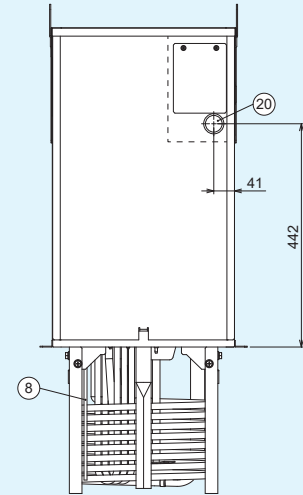
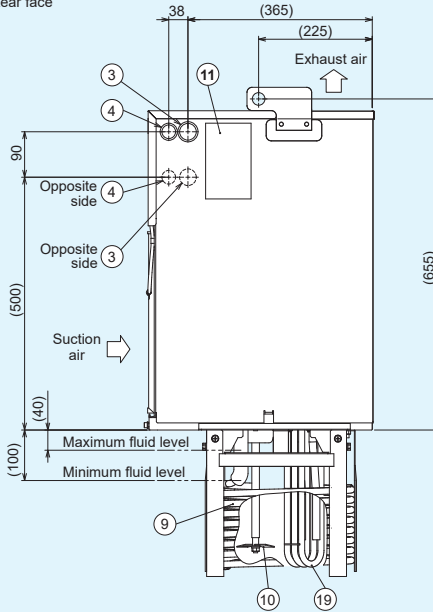
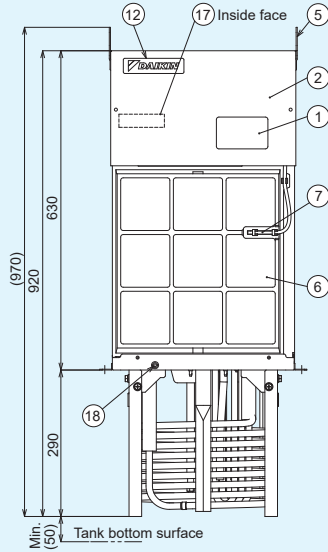
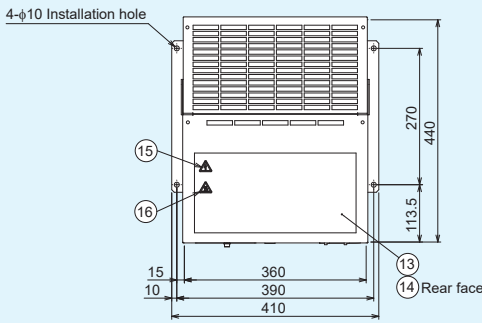

Part No.	Name	Description	Part No.	Name	Description
1	Control panel		11	Machine nameplate	
2	Electrical component box lid		12	Design nameplate	
3	Power supply inlet (Right/Left)	φ28 hole ¹	13	Overall caution plate	
4	Signal line inlet (Right/Left)	φ22 hole	14	Electric schematic diagram nameplate	
5	Eye plate	φ25 hole	15	Battery charge mark nameplate	
6	Air filter		16	High temperature caution nameplate	
7	Room temperature thermistor		17	Model name nameplate	
8	Fluid temperature thermistor		18	Oil pan drain	M6 (plugged)
9	Cooling coil		19	Heater	Only for models with heater
10	Agitating plate		20	Power supply inlet	φ28 hole ²

*1. Except for different voltage options -048 *2. For different voltage options -048 only

AKJ35A (-B, -C, -H, -046, -048, -500)

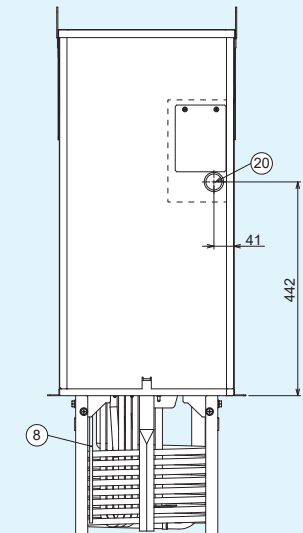
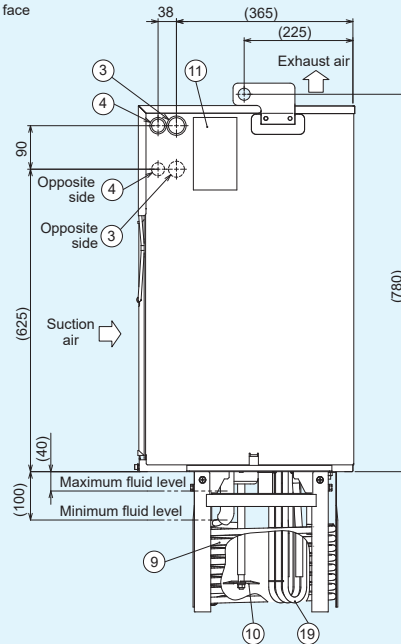
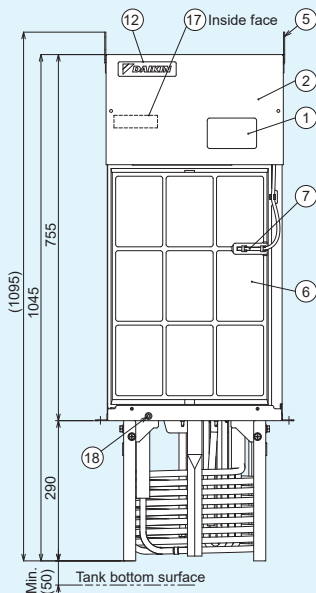
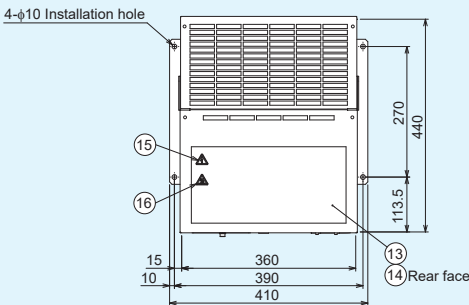

Part No.	Name	Description	Part No.	Name	Description
1	Control panel		11	Machine nameplate	
2	Electrical component box lid		12	Design nameplate	
3	Power supply inlet (Right/Left)	φ28 hole ¹	13	Overall caution plate	
4	Signal line inlet (Right/Left)	φ22 hole	14	Electric schematic diagram nameplate	
5	Eye plate	φ25 hole	15	Battery charge mark nameplate	
6	Air filter		16	High temperature caution nameplate	
7	Room temperature thermistor		17	Model name nameplate	
8	Fluid temperature thermistor		18	Oil pan drain	M6 (plugged)
9	Cooling coil		19	Heater	Only for models with heater
10	Agitating plate		20	Power supply inlet	φ28 hole ²

*1. Except for different voltage options -048 *2. For different voltage options -048 only

AKJ45A (-B, -C, -H, -046, -048, -500)

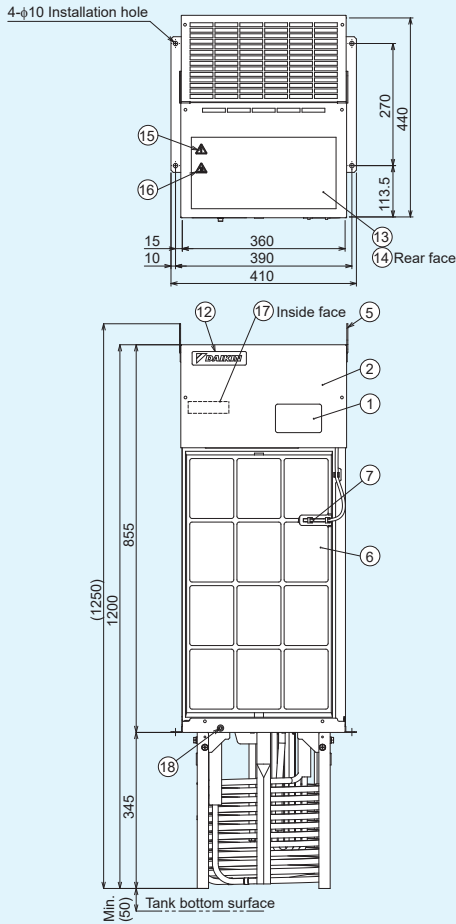

Part No.	Name	Description
1	Control panel	
2	Electrical component box lid	
3	Power supply inlet (Right/Left)	φ28 hole ^{*1}
4	Signal line inlet (Right/Left)	φ22 hole
5	Eye plate	φ25 hole
6	Air filter	
7	Room temperature thermistor	
8	Fluid temperature thermistor	
9	Cooling coil	
10	Agitating plate	

Part No.	Name	Description
11	Machine nameplate	
12	Design nameplate	
13	Overall caution plate	
14	Electric schematic diagram nameplate	
15	Battery charge mark nameplate	
16	High temperature caution nameplate	
17	Model name nameplate	
18	Oil pan drain	M6 (plugged)
19	Heater	Only for models with heater
20	Power supply inlet	φ28 hole ^{*2}

*1. Except for different voltage options -048 *2. For different voltage options -048 only

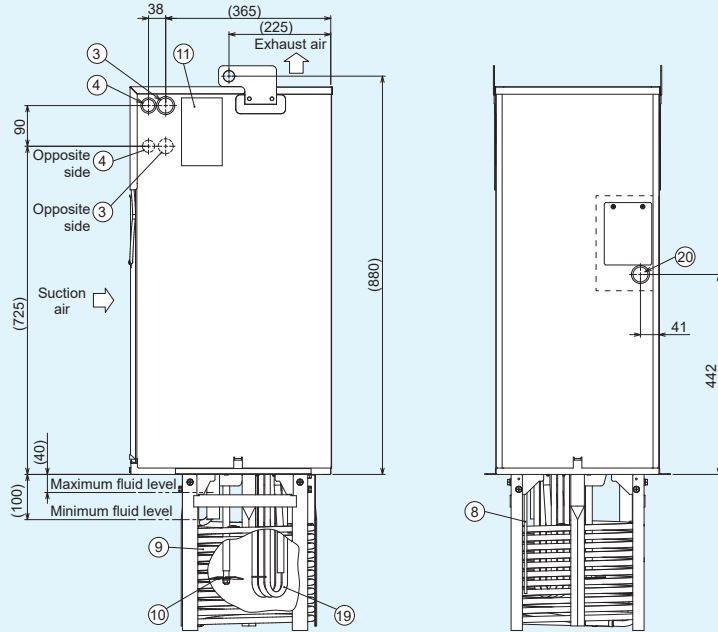

AKJ56A (-B, -C, -H, -046, -048, -500)

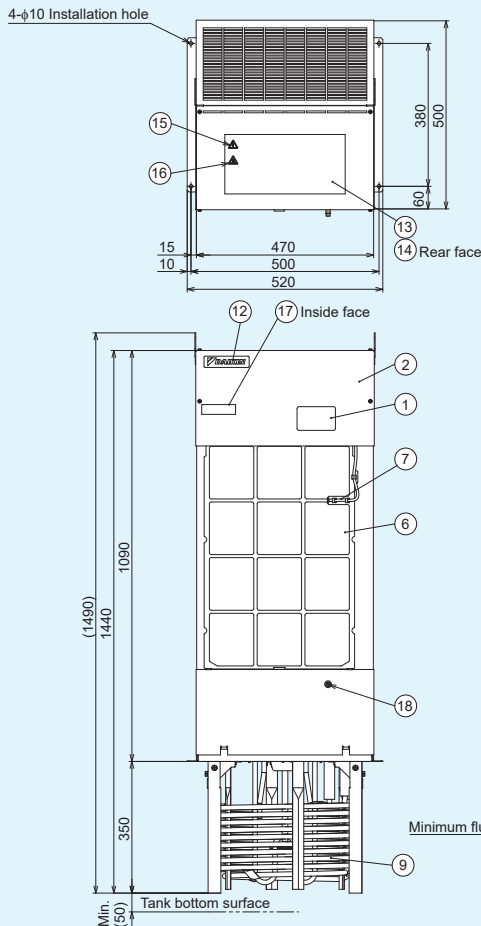

Part No.	Name	Description
1	Control panel	
2	Electrical component box lid	
3	Power supply inlet (Right/Left)	φ28 hole ^{*1}
4	Signal line inlet (Right/Left)	φ22 hole
5	Eye plate	φ25 hole
6	Air filter	
7	Room temperature thermistor	
8	Fluid temperature thermistor	
9	Cooling coil	
10	Agitating plate	

Part No.	Name	Description
11	Machine nameplate	
12	Design nameplate	
13	Overall caution plate	
14	Electric schematic diagram nameplate	
15	Battery charge mark nameplate	
16	High temperature caution nameplate	
17	Model name nameplate	
18	Oil pan drain	M6 (plugged)
19	Heater	Only for models with heater
20	Power supply inlet	φ28 hole ^{*2}

*1. Except for different voltage options -048 *2. For different voltage options -048 only

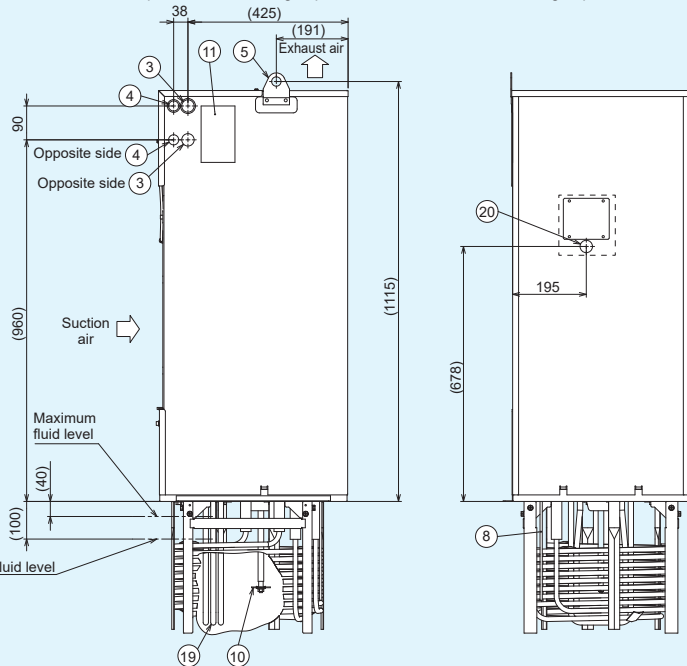

External Dimension Diagram

Note: Refer to Pages 5 and 6 for more details.
 • For the machining dimensions of the holes for installation on the tank, refer to page 12.

The positions of the bolt holes used for installing the product on the tank top plate are compatible with the 9 Series, but the positions of the power supply/signal cable inlet ports may be different.

AKJ90A (-B, -C, -H, -046, -048, -500)

Part No.	Name	Description	Part No.	Name	Description
1	Control panel		11	Machine nameplate	
2	Electrical component box lid		12	Design nameplate	
3	Power supply inlet (Right/Left)	φ28 hole ^{*1}	13	Overall caution plate	
4	Signal line inlet (Right/Left)	φ22 hole	14	Electric schematic diagram nameplate	
5	Eye plate	φ25 hole	15	Battery charge mark nameplate	
6	Air filter		16	High temperature caution nameplate	
7	Room temperature thermistor		17	Model name nameplate	
8	Fluid temperature thermistor		18	Oil pan drain	M6 (plugged)
9	Cooling coil		19	Heater	Only for models with heater
10	Agitating plate		20	Power supply inlet	φ28 hole ^{*2}

*1. Except for different voltage options -048 *2. For different voltage options -048 only

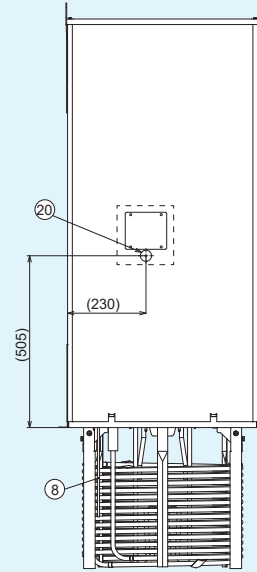
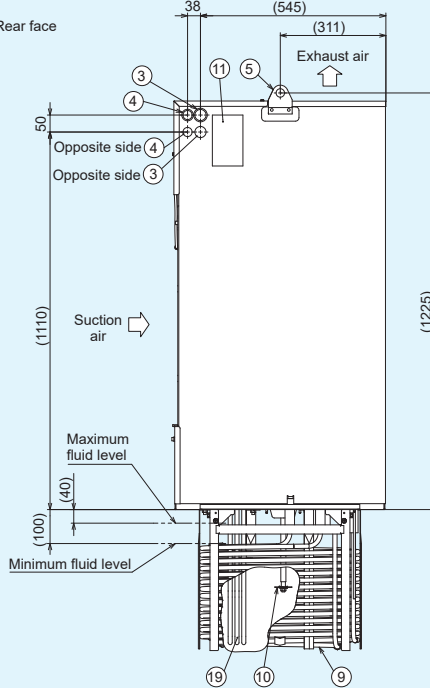
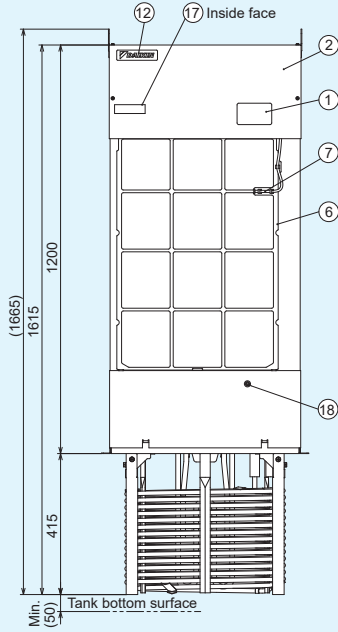
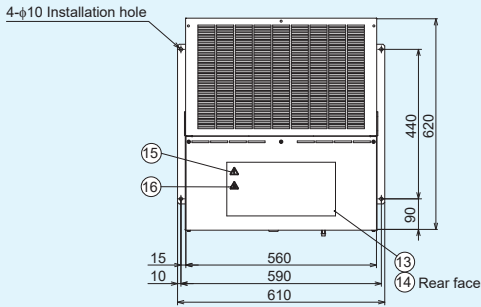

Notes for manufacturing of tank

1. Separate the fluid tank into at least three sections. Use the over-flow system and take measures so that foreign matter such as cutting chips and debris does not get into the suction line directly.
2. Arrange and locate the partition plates and piping position properly so that high-temperature fluid returned from the machine and low-temperature fluid cooled by the Oil Cooling Unit are evenly mixed.
3. Design the tank so that the tank inside can be cleaned with ease (For instance, the tank upper plate can be removed).
4. Tank material: Stainless steel is recommended, but compatibility with the cooling fluid should be adequately considered. (Some grinding fluid tanks are made of general structural steel with the interior coated with epoxy resin.)

Dimensions of installation tank (Plan view)

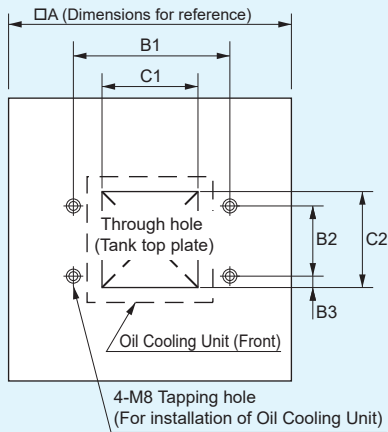

Oil Cooling Unit series	Tank Size A	Depth H	Tank hole pitch			Through hole		Installation Compatibility (✓: Compatible)		
			B1	B2	B3	C1	C2	With 9 Series	With 8 Series	With 7 Series
AKJ 18A	500 or more	340 or more	390	270	15	325	325	✓ AKJ189	✓ AKZJ188	Note: ✓ AKZJ187
AKJ 35A		395 or more						✓ AKJ359	✓ AKZJ358	Note: ✓ AKZJ357
AKJ 45A		395 or more						✓ AKJ459	✓ AKZJ458	-
AKJ 56A	690 or more	400 or more	500	380	45	440	440	✓ AKJ569	✓ AKZJ568	✓ AKZJ567
AKJ 90A	770 or more	465 or more	590	440	30	500	500	✓ AKJ909	✓ AKZJ908	✓ AKZJ907

Note: The Oil Cooling Unit projects beyond the tank about 50 mm to the front. (It is necessary to check whether there is any obstruction to the front.)

Part No.	Name	Q'ty/unit	Part No.	Name	Q'ty/unit
1	Oil cooling unit	1	7	Return port	1
2	Tank body	1	8	Tank drain	1
3	Tank top plate	1	9	Float switch	1
4	Tank packing	1	10	Oil filler port-cum-air breather	1
5	Supply pump	1	11	Oil level gauge	1
6	Discharge port	1	12	Hanging bolt	4

Note: Part Nos. 2 to 12 are not included in the scope of Daikin's products.

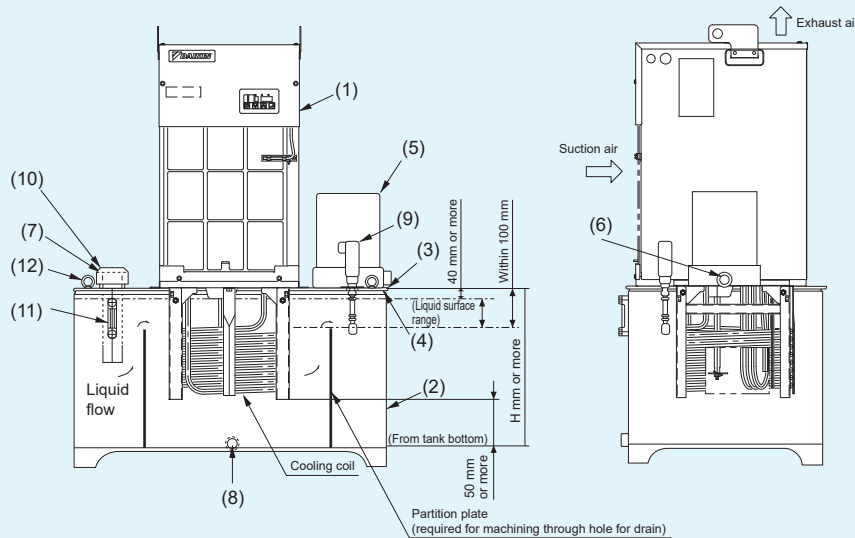

- Notes 1: Ensure that the fluid surface is in the range of 40 to 100 mm from the top plate of the tank.
 2: Do not expose the cooling coil extending above the fluid surface.
 3: The height of the partition plate should be higher than the lowest fluid level of the fluid level range

Separate type When the depth of the tank is the "H" dimension in the figure above or less

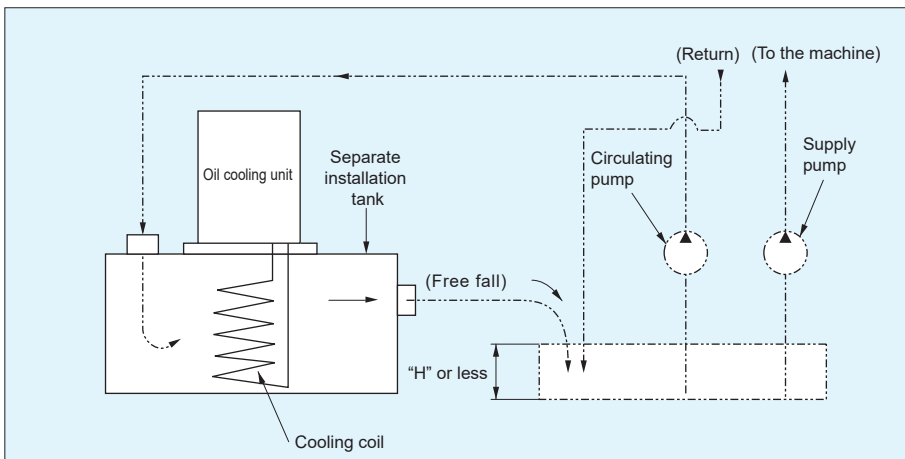

- Note 1. If it is expected that cutting chips and debris will get into the tank, install efficient filters in the supply or return line.
 Note 2. If foreign matter such as cutting chips and debris deposit on and adhere to the cooling coil surface, the cooling capacity is deteriorated and this may result in failure.

Thermistor (Compatible with All Types of Oil Cooling Unit AKJ※※A (10 Series))

Thermistor models and applications

When this optional part is installed in the oil piping of the machine, the thermistor detects the oil or water temperature for the unit's operation.

Name	Model	Length of lead wire L (m)	Figure	Application (To be installed by you)
Thermistor for machine body synchronization	AKZ-OP-K5	5 m		For machine temperature synchronization control (implanted in the machine body)
	AKZ-OP-K10	10 m		
	AKZ-OP-K15	15 m		
Thermistor for machine body synchronization	AKZ-OP-A5	5 m		For machine temperature synchronization control (attached to the surface of the machine body)
	AKZ-OP-A10	10 m		

Thermistor characteristics: Resistance value ... R25 (Resistance value at 25°C) = 20 kΩ, Tolerance: ±3%

Instruction for installation and connection

For AKZ-OP-K

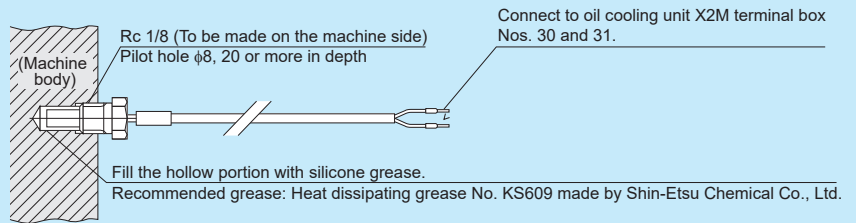

For AKZ-OP-A

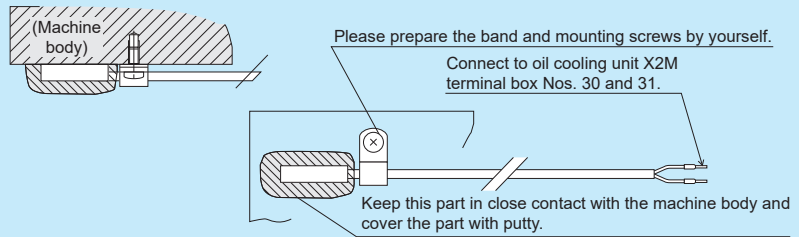

Installation positions of the thermistors for machine temperature synchronization

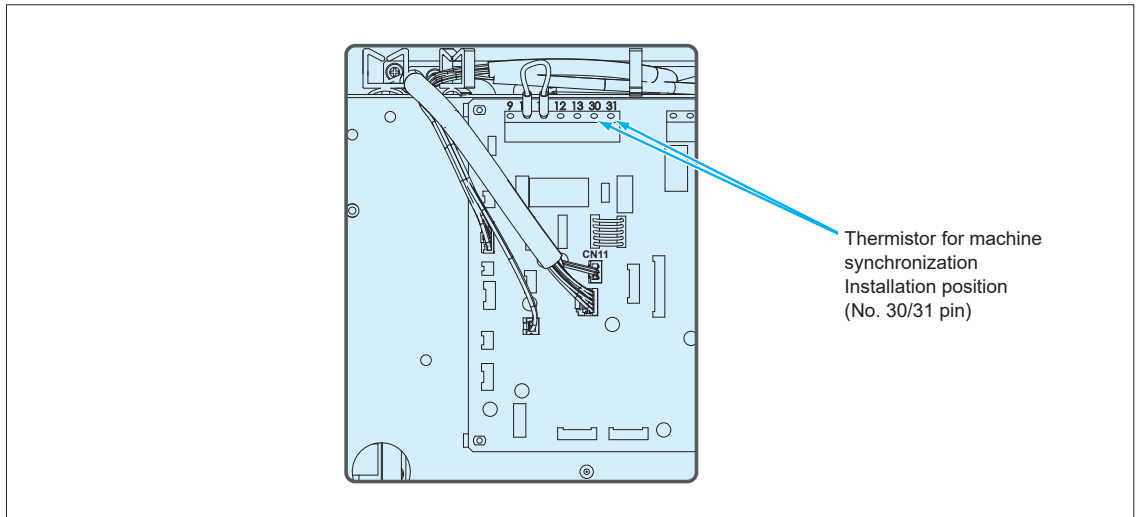

Option Board for Communication (Serial Communication/ Parallel Communication) Compatible with 10 Series Oil Cooling Units

The following can be achieved by mounting this option board on the Oil Cooling Unit's control board and communicating with the machine.

1. Changing the operation mode and the operation setting from the machine
2. Reading various data such as the alarm code and temperature-related data (machine temperature, room temperature, tank fluid temperature, inverter frequency) of the Oil Cooling Unit from the machine.

Communication method	Model	Protocol	Applicable model
Serial communication RS232C	AKZA-OP-CS	Daikin proprietary protocol	PIM00603
Serial communication RS232C	AKZA-OP-CSP		PIM00614
Parallel communication			

Note: For details on the communication procedure and specifications, refer to the dedicated instruction manual

■ Mounting the AKZA-OP-CS serial communication option board

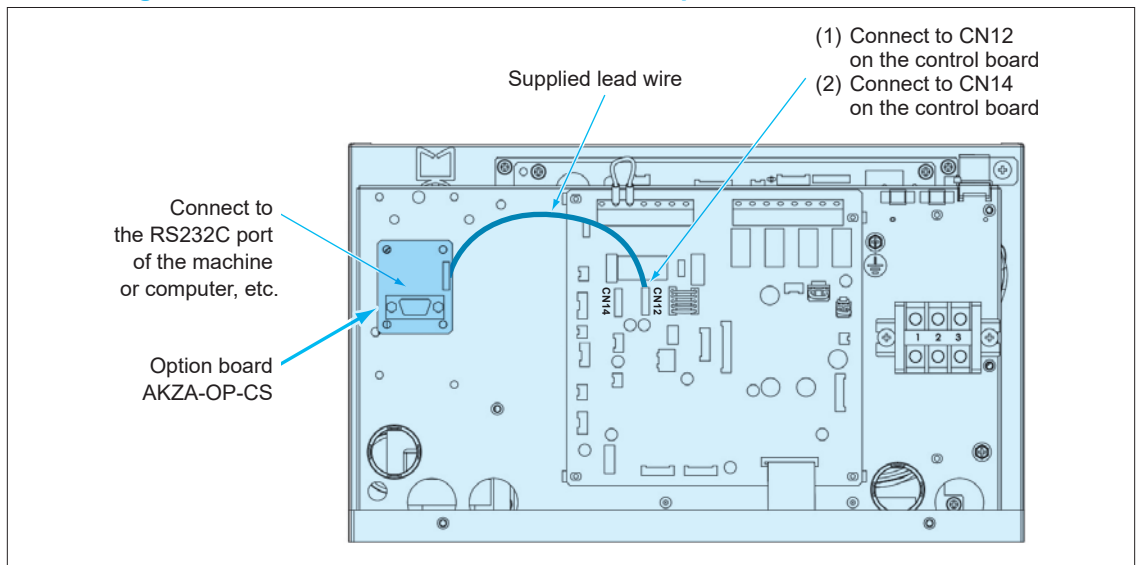

- Dimensions of communication board (W × H): 40 × 50
- The communication board is secured at four positions by locking support.

■ Mounting the AKZA-OP-CSP serial communication/parallel communication option board

The possible installation positions differ depending on the model.

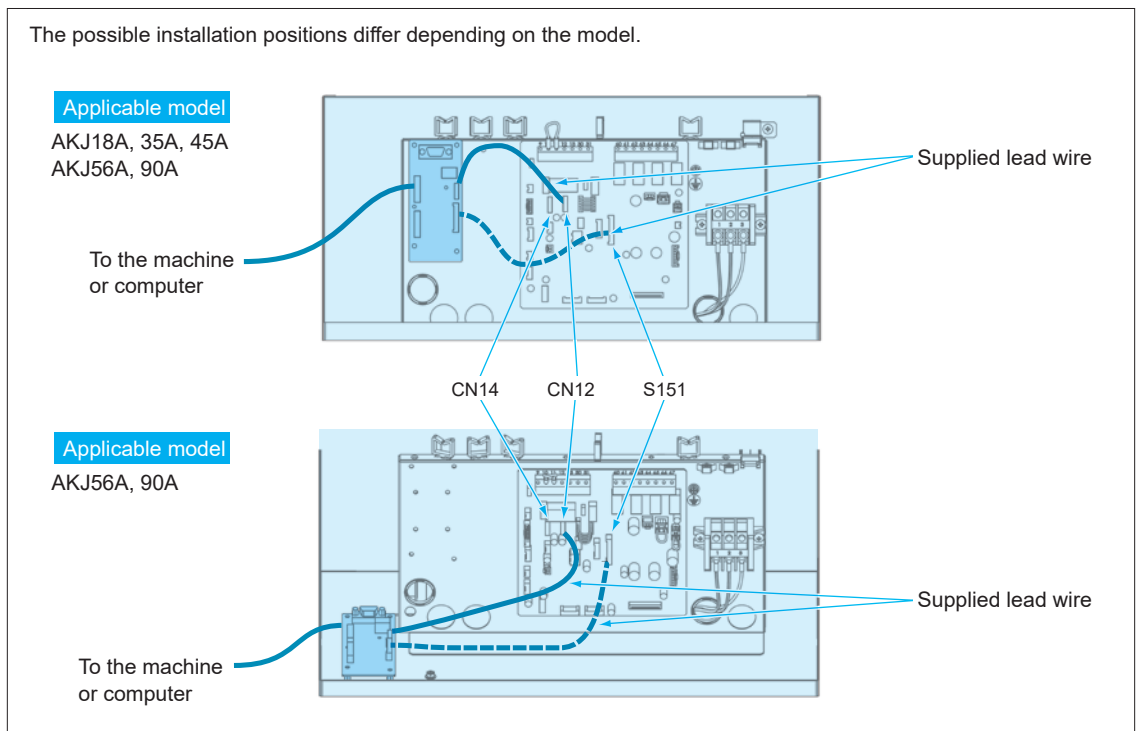

Part Names, Functions and Operation of Control Panel

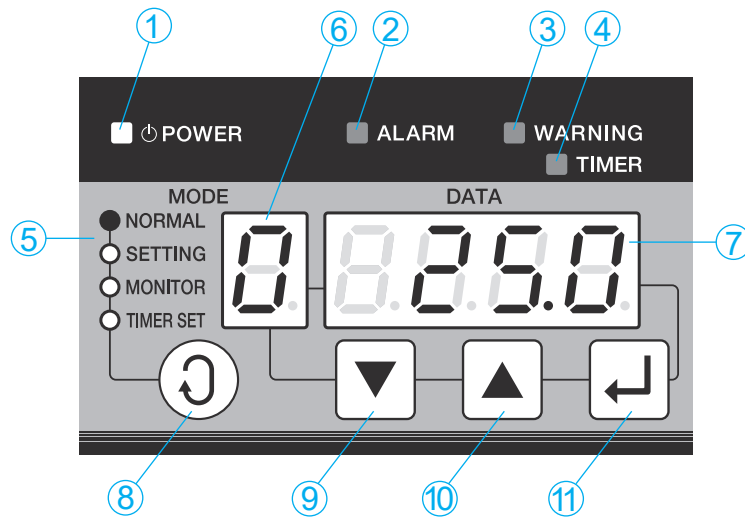

No.	Item	Description
①	Power lamp (Green)	The lamp is turned on while power is supplied.
②	Error warning lamp (Red)	When an error occurs Level 1 alarm: The lamp keeps blinking. Level 2 alarm: The lamp is continuously on.
③	Warning lamp (Green)	When a warning occurs Level 1 warning: The lamp keeps blinking. Level 2 warning: The lamp is turned on.
④	Timer mode lamp (Green)	The lamp keeps blinking while the machine is at a stop in the timer mode.
⑤	Operation mode display	Displays the mode of the control panel. NORMAL: Normal mode SETTING: Operation setting mode MONITOR: Monitor mode TIMER SET: Timer setting mode
⑥	Operation mode/Data No. display	Displays the current operation mode (Normal mode/Operation setting mode) or data number of the data currently displayed on the data display.
⑦	Data display	Displays various data. The data displayed differs depending on the operation mode and data number.
⑧	[SELECT] (Select) key	Selects the operation mode.
⑨	[DOWN] key	Decrements the value of the operation mode, data number or data by 1 (0.1). When held for two seconds or longer, decrements the values by 10 (1).
⑩	[UP] key	Increases the value of the operation mode, data number or data by 1 (0.1). When held for two seconds or longer, increments the values by 10 (1).
⑪	[ENTER] (Determine) key	Determines the operation mode, data number, and data to be changed.

For details on alarms and warnings, refer to the instruction manual.

Operation for changing to each mode

The mode can be changed by operating the [SELECT] key in general.

To enter a special mode, hold down a number of keys in combination for more than five seconds.

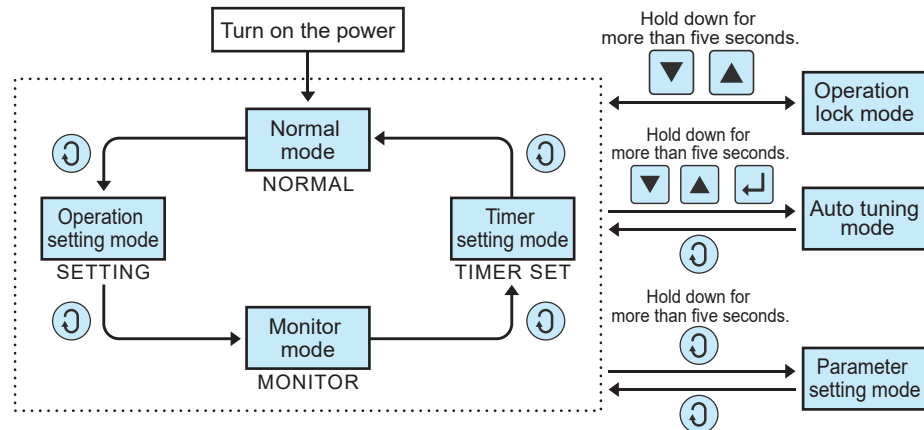

CAUTION

- The default setting is "Operation lock mode".
To start operation, perform the unlocking operation as shown above.
- The default setting for operation on the standard machine is:
Operation mode: 3 (tank fluid temperature/room temperature synchronization control)
Differential temperature: 0.0 (°C)

Operation Mode and Setting Method

AKJ10 series

Operation mode No.	Mode name	Description	Setting temperature range	Necessary optional part
Operation mode 0	Tank fluid temperature, fixed temperature control	Keep the tank fluid temperature at the setting temperature within the range specified in the right column.	5 to 50°C	
Operation mode 3	Tank fluid temperature, room temperature synchronization control	Keep the tank fluid temperature at the setting temperature within the range specified in the right column.	Between Room temperature -9.9°C and Room temperature +9.9°C	
Operation mode 4	Tank fluid temperature, machine temperature synchronization control	Keep the tank fluid temperature at the setting temperature within the range specified in the right column.	Between Machine temperature -9.9°C and Machine temperature +9.9°C	Machine synchronization thermistor

Note 1: Operation modes 1, 2, and 5 to 8 cannot be used.

Note 2: Refer to Page 13 for details of required optional parts.

Setting procedure

Default setting: Set to operation mode 3, and a temperature of 0.0°C
To use the equipment other than at the default setting, change the setting by following the procedure below.

- 1 Power ON Release the operation lock mode before starting operation for the first time. (Hold down the and keys simultaneously for more than 5 seconds.)
- 2 Select the "SETTING" operation setting mode (press the key once).

Changing the operation mode

Decreases the "MODE" number by 1

Increases the "MODE" number by 1

- 3 Set the operation mode by pressing the or key.
- 4 → Confirm by pressing the key.

Change the setting temperature

The "Setting temperature" is reduced by 0.1

The "Setting temperature" is increased by 0.1.

- 5 Set the temperature by pressing the or key.
- 6 → Confirm by pressing the key.

- 7 To return to the "NORMAL" mode, press the key three times.

Points Checked in the Monitor Mode

The following points can be checked in the monitor mode.

Monitor No.	Description	Note	Monitor No.	Description	Note
0	Machine body temperature [Th1]	*1	5	Not used	-
1	Reserved	*1	6	Cooling capacity control command value (%)	-
2	Room temperature [Th3]	*1	7	Compressor inverter rotational speed (rps)	-
3	Tank fluid temperature [Th4]	*1	8	Power consumption (kW)	*2
4	Refrigerant intake temperature [Th5]	*1	9	Extended DIN (hundreds digit), DOUT (tens digit) status	*3

*1. If the thermistor is not connected or has a broken wire, -99.9 is displayed.

*2. This is the value obtained by rough calculation assuming a power supply voltage of 200 V. (Accuracy is approximately ±20% with respect to the max. power consumption.)

*3. With the default setting, 0 is displayed. Note that display is enabled when parameter n020 is "1" or the optional communication extension board is installed.

Electric Wiring Diagram (Typical diagram)

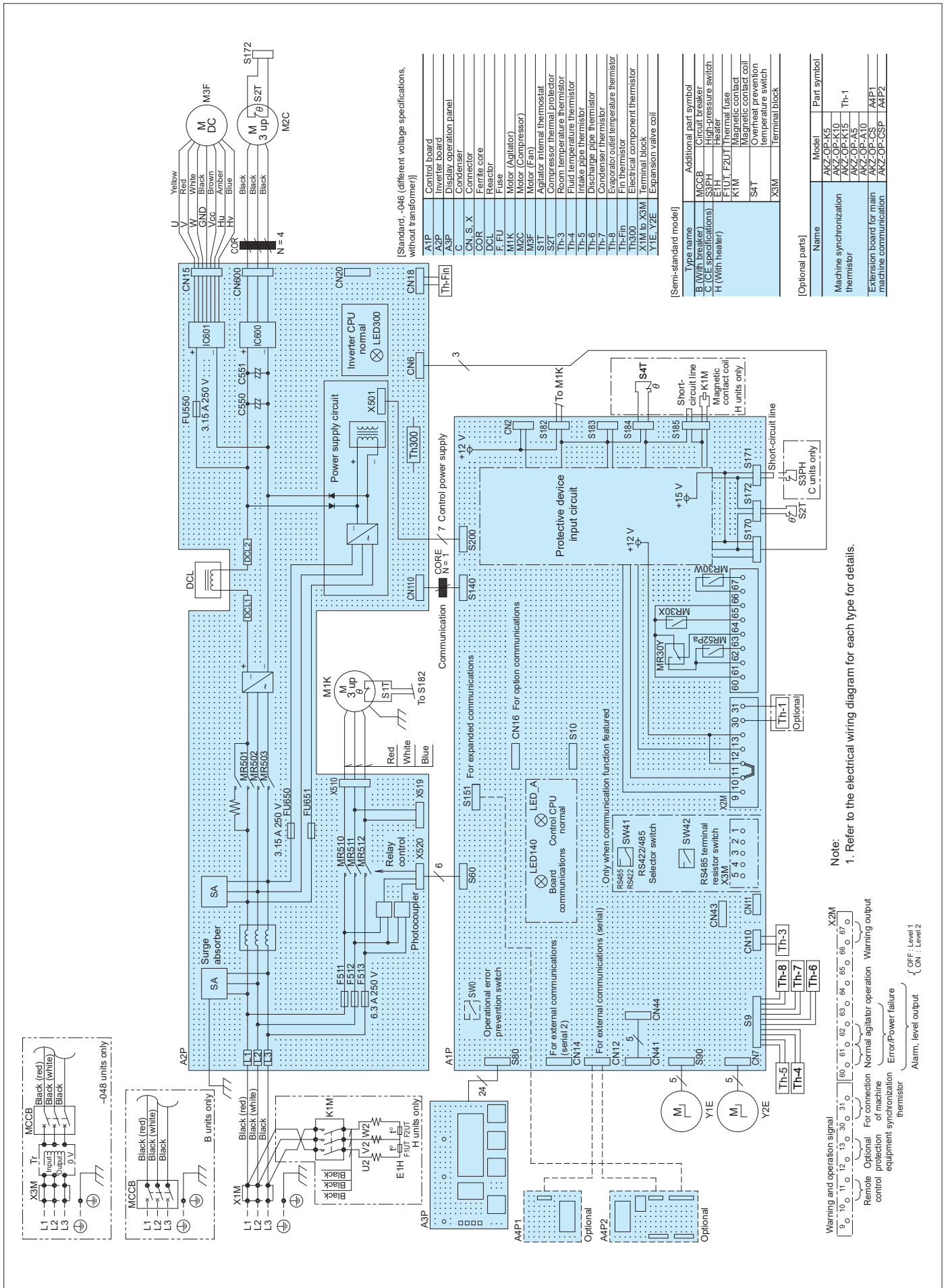

Electric Wiring Connection Instruction

1 Power supply capacity ---Refer to the max. power consumption/max. current consumption in the specifications list (Pages 5 to 6).

2 Connection to power supply terminal block (X1M)

- (1) In the case of the standard type and menu-incorporating type (-C, -H), connect the line to X1M.
- (2) In the case of "with breaker" (-B) specifications, connect to the circuit breaker.

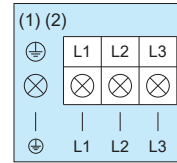

1. Screw terminal and wiring diameter

Series	Terminal block	Screw terminal	Wiring diameter	
			IEC cable	UL cable
AKJ 18A, 35A, 45A, 56A	X1M	M4, M5	2.5 mm ² or greater	AWG#14 or greater
	Breaker	M5		
AKJ 90A	X1M	M5	4.0 mm ² or greater	AWG#12 or greater
	Breaker	M5		

2. Use a round crimp-style terminal for connection.

3. The terminal block is for three poles and the earth wire is to be secured on the enclosure with a screw.

3 Connection to signal terminal block (X2M)

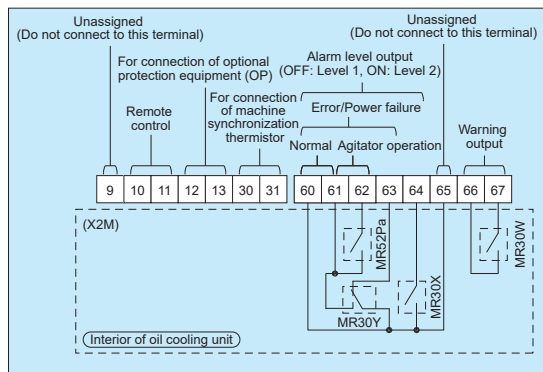

1. Straight crimp terminal and wiring diameter

Straight pin terminals	Wiring diameter	
	IEC cable	UL cable
*	0.3 mm ² to 1.5 mm ²	AWG#22 to #16

2. Use a straight crimp-style terminal for connection.

3. Use stranded wires for electric connection.

4. The wiring size is 0.5 mm² to 1.5 mm² in the case of duplex cable according to IEC.

If using stripped wires, make the stripped length 9 to 10 mm.

*Recommended models and manufacturers:

TGN TC-1.25-9T (NICHIFU Co., Ltd.)

APA-1.25N (Daido Solderless Terminal)

4 Signal output time chart

(1) Alarm/operation status output chart

Operation status			Remote operation (between [10] and [11])							
			ON				OFF			
			Normal	Level 1 Error of LOCK	Level 2 Error	Power failure (Power OFF)	Normal	Level 1 Error of LOCK	Level 2 Error	Power failure (Power OFF)
Signal output										
Normal ("a" contact)	60-61	ON OFF								
Error/Stop (Power OFF) ("b" contact)	60-63	ON OFF								
Error level ("a" contact)	60-64	ON OFF								
Pump operation ("a" contact)	61-62	ON OFF								

(2) Warning output chart

Operation status			Non-warning status				Warning status			
			Normal	Level 1 Error of LOCK	Level 2 Error	Power failure (Power OFF)	Normal	Level 1 Error of LOCK	Level 2 Error	Power failure (Power OFF)
Signal output										
Warning output ("a" contact)	66-67	ON OFF								

CAUTION

1. The following electric wires can be used on the terminal block for straight crimp-style terminals.

Single wire: $\phi 0.57$ to $\phi 1.44$ (AWG#22 to #16)

Stranded wire: 0.25 mm² to 1.25 mm² (AWG#22 to 16)

2. Load applicable to [60 - 64] and [66 - 67] is as follows:

Min. applicable load: DC 10 mV 10 μ A or greater

Max. applicable load: DC 30 V, 2 A (Resistance load)

3. For [10] to [13], please prepare contacts to meet the condition of minimum applicable load DC 12 V and 5 mA.

4. When the length of the thermistor to be connected to [30] - [31] is longer than 10 m, or the wiring is routed in a poor noise environment, use shielded wire.

Notes for Handling

● Important notes to be observed regarding the machine side (machine tools and industrial machinery)

1. When rough transport conditions are expected while transporting the machine overseas or elsewhere, special precautions should be taken in the packaging and transportation method so as to avoid the application of excessive force on the oil cooling unit (this unit).
2. The Oil Cooling Unit (this unit) does not incorporate a float switch or a temperature switch for abnormal temperature (high temperature or low temperature) of fluid supplied. So, please provide protection devices such as a float switch and temperature switch at the machine side.

Notes for operation and cooling capacity

1. Do not use the oil cooling unit to cool a fluid from 50°C or higher. Start to operate the oil cooling unit at the same time as the machine or before the fluid temperature rises to 40°C.
2. Do not place an object that hinders ventilation within 500 mm of the air-intake or exhaust.
3. If the air filter is clogged, the cooling capacity will be reduced. Clean the air filter (wash with warm water or clean with air) periodically once every two weeks to prevent clogging.
4. If cutting chips and powder-like chips deposit on and adhere to the cooling coil (evaporator), the cooling capacity should be diminished and it could cause failure. To avoid the adherence of deposits on the cooling coil, install an efficient return filter on the return side (fluid inlet) of the tank and periodically clean the tank inside.

Notes on usable fluids with oil cooling units



1. The cautions are given in the table below. (✓ symbol ... Can be used, “Unusable” ... Cannot be used)
2. Do not use fluid listed below as “Unusable”

	Description	AKJ10 series
Lubricating oil Mineral hydraulic oil	• Oil that is classified as third class petroleum or fourth class petroleum of the fourth group hazardous materials stipulated in the Fire Defense Law and that corresponds to discoloration No. 1 in the copper corrosion test method (JIS K2513) of petroleum products	✓
Nonflammable hydraulic oil ● Phosphate ester hydraulic fluid ● Chlorinated hydrocarbon series ● Water - Glycol series ● W/O & O/W emulsion series (High-aqueous hydraulic oil)	—	Unusable
Coolant fluid ● Water-soluble cutting and grinding fluid ● Non water-soluble cutting and grinding oil	—	✓
Ethylene glycol (Antifreeze liquid)	—	✓
Water (Industrial water)	—	✓
Inflammable liquids like fuel	Liquid equivalent to special flammables, alcohol, first class petroleum and second class petroleum of the fourth group hazardous materials specified according to the Fire Defense Law	Unusable
Chemicals	—	Unusable
Liquid for food products	Drinking water, water for cooling food products, etc.	Unusable









Notes for Handling

Before operating this unit, be sure to read the operation manual and properly understand it.





• Instructions for safe operation

Signs and Instructions	 DANGER Failure to observe the instruction may cause an imminent hazardous situation that may result in personal death or serious injury.
	 WARNING ... Failure to observe the instruction may result in personal death or serious injury.
	 CAUTION ... Failure to observe the instruction may result in personal injury or damage to the property.



① General instructions

- [ DANGER] ① Use the equipment only in accordance with the intended specifications (specified in brochure, specification sheet, operation manual, and caution plates).
- [ DANGER] ② Never operate the equipment in an explosive atmosphere.
- [ DANGER] ③ Do not disassemble, repair or modify the equipment by yourself.
- [ DANGER] ④ Always comply with the laws and regulations for safety (Industrial Safety and Health Law, Fire Defense Law, and JIS B 8361 Guidelines of Hydraulic System).
- [ WARNING] ⑤ Caution in the event of refrigerant leak
 - Ventilate the room adequately (to avoid the risk of suffocation).
 - Avoid direct contact of the refrigerant with skin (to avoid the risk of cryogenic burns).
 - In the event of inhalation of a great deal of refrigerant, contact with skin, or refrigerant in the eye, seek medical attention immediately.
- [ WARNING] ⑥ In the event of an abnormal condition, stop operation promptly, investigate the cause of the problem and take appropriate remedial measures.
- [ CAUTION] ⑦ Do not use the unit in atypical environments (locations subject to high temperatures, high humidity, or a lot of dust, contamination, steam, oil mist or corrosive gases: H₂S, SO₂, NO₂ or Cl₂).
- [ CAUTION] ⑧ Do not get on the equipment or place an object on the equipment.
- [ CAUTION] ⑨ Use the unit at an altitude of up to 2,000 m. At altitudes in excess of 1,000 m the cooling capacity decreases by around 20 to 30%, so please select a model with adequate leeway in terms of cooling capacity.







② Instructions for transportation

- [ DANGER] ① When hoisting the equipment, check its weight and use the eye plates and hangers on it properly.
- [ DANGER] ② When hoisting the equipment, do not do so while it is fitted with a tank or anything else that you have provided.
- [ WARNING] ③ Do not approach the equipment while it is being hoisted and moved.
- [ CAUTION] ④ When moving the equipment, take appropriate measures for fall prevention.
- [ CAUTION] ⑤ Do not tilt the equipment 30 degrees or more while transporting it (including during storage).





③ Instructions for installation

- [ WARNING] ① Install the equipment on a rigid, level foundation and secure it appropriately.
- [ CAUTION] ② Do not place an object near the suction port or discharge port of the equipment.



④ Instructions for wiring

- [ DANGER] ① Wiring and piping installation should be performed by a person with specialized knowledge and skills.
- [ DANGER] ② Always use a commercial power supply for the power source. (The use of an inverter power supply may cause burn damage).
- [ DANGER] ③ Connect the wiring for power supply in accordance with the electric wiring instruction diagram of the specification sheet and operation manual.
- [ DANGER] ④ Ground the equipment properly.
- [ WARNING] ⑤ Install the wiring in accordance with the standard by checking the electric wiring diagram.
- [ CAUTION] ⑥ Always install a dedicated all-pole (3-pole) earth leakage breaker appropriate for the capacity of Oil Cooling Unit on the main power supply on site.









⑤ Instructions for trial run

- [ CAUTION] ① Check to see that the machine is in a safe status (not activated) before starting the trial run.
- [ CAUTION] ② Check to see that the oil piping and electric wiring are correctly connected to the machine and that there is no looseness in connections and joints.
- [ CAUTION] ③ Disable the operation lock of the equipment (Oil Cooling Unit) before starting the machine.
- [ CAUTION] ④ Check that the tank contains the correct volume of the fluid used.

⑥ Instructions during operation

- [ DANGER] ① Do not splash water or liquid on the equipment.
- [ WARNING] ② Do not push your finger or an object into gaps of the equipment.
- [ CAUTION] ③ Do not touch the heated exhaust port of the equipment.

⑦ Instructions for maintenance and inspection

- [ DANGER] ① Perform maintenance and inspection with the equipment kept open. Working in a closed status may result in suffocation due to the leak of refrigerant.
- [ DANGER] ② Always turn off the main power supply before starting maintenance and inspection.
- [ DANGER] ③ Wait for five minutes after turning off the main power supply before starting maintenance and inspection operation.
- [ DANGER] ④ Do not operate the equipment with its cover opened.
- [ CAUTION] ⑤ Wear protective gear such as gloves and an eye protector when performing maintenance, inspection and cleaning.
- [ CAUTION] ⑥ Clean the air filter periodically (once every two weeks in general).
- [ CAUTION] ⑦ Clean the cooling coil periodically to ensure that there is no accumulation/adhesion of chips, etc.
- [ CAUTION] ⑧ Inspect the oil pan of the oil cooling unit once every six months, and if oil has accumulated, discharge it through the drainage port.

Selection Method for Oil Cooling Units

Unit conversion formula • 1 kW = 860 kcal/h

In the case of cooling of cutting and grinding fluid

- The amount of heat generation from the cutting and grinding fluid system should be roughly estimated according to the following formula as the tank capacity and pump flow rate are generally large. After rough estimation, the amount of heat generation should be determined by conducting tests on the actual machine to select the oil cooling unit.
- Select a model with a cooling capacity 20 to 30% larger than the amount of heat generation from the machine tool.

Example calculation 1 When estimating the thermal load of the entire system from each thermal load

$$Q = Q_1 + Q_2 + Q_3$$

- Q : Heat load of the entire machine tool system
 Q₁ : Amount of heat generated during machining on a machine tool
 Q₂ : Amount of heat generation of the pump motor for coolant pump (Amount of heat transferred to coolant)
 : Q₂ = pump motor output (kW) × $\frac{\eta}{100}$
 Q₃ : Heat balance of the coolant fluid passing through the coolant tank and the room temperature
 Q₃ = K · A · ΔT
 K : Rate of heat passage (W/m² · °C), generally K = 11.6 to 23.2
 A : Surface area of the tank in contact with the fluid (m²)
 ΔT : Room temperature – controlled temperature of fluid in tank (°C)

For testing, determine the amount of heat generation according to the method shown below.

General guide for heat generation

E.g.) In the diagram below,

When Q₁ = 1.2 kW

Q₂ = (2.2 + 2.2 + 3.7) × $\frac{50}{100} \approx 4.1$ kW (For a coolant pump, “η” is generally 50%.)

Q₃ = 20 × 4 × (35 – 25) / 1000 = 0.8 kW

∴ Q = Q₁ + Q₂ + Q₃
 = 1.2 + 4.1 + 0.8
 = 6.1 kW

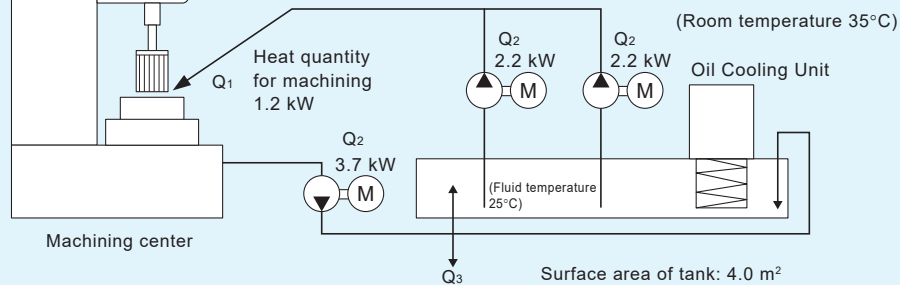

Example calculation 2 When it is desired to reduce the temperature of the fluid in the tank within a fixed time

200 L oil tank

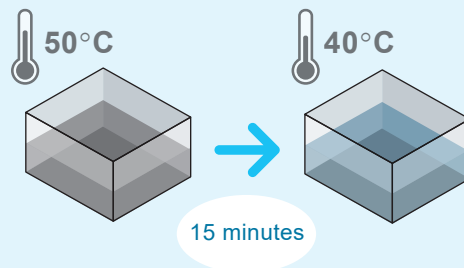

$$Q = \frac{V \times \rho \times C_p \times \Delta T}{1000 \times 60 \times t}$$

- Q : Heat release value (kW) C_p : Specific heat (kJ/kg·°C)
 V : Tank fluid capacity (L) ΔT : Temperature difference (°C)
 ρ : Density (kg/m³) t : Time (min)

Example calculation When it is desired to cool 200 L of hydraulic oil from 50°C to 40°C within 15 minutes

$$Q = \frac{200 \text{ L} \times 876 \text{ kg/m}^3 \times 1.97 \text{ kJ/kg}^\circ\text{C} \times (50 - 40)^\circ\text{C}}{1000 \times 60 \times 15 \text{ min}}$$

A cooling capacity of **approx. 3.83 kW** or greater is required.

Note: Effect of heat absorption and dissipation from the surface of the tank and piping

Depending on the tank and piping surface area and ambient temperature, heat absorption and heat dissipation may increase. If the effect of heat absorption and heat dissipation is large, select a model with this effect taken into account.

Physical property values

Name of substance	Specific heat kJ/(kg·°C)	Density (kg/m ³)
Water	4.18	998
Lubricating oil/hydraulic oil	1.97	876
Water-soluble coolant (10× dilution with water)	3.94 to 4.10	991
Aluminum	0.900	2710
Iron	0.460	7870
Copper	0.385	8960

* The numbers in the table are reference values, so please use them as a guide.

* All property values (some being calculated values) are at 20°C.

To prevent clogging of cooling fins!

NEW

 Now available for
Series 10

**Industry
First**

Unique Offer from DAIKIN!!

Long Life Filter

for oil chillers

No need to clean cooling fins*²

The microfibers in the filter efficiently collect oil mist and dust, which means the condenser cooling fins remain unclogged and maintenance-free.

Once-a-year filter changes*²

The Long Life Filter collects more mist, thereby increasing its lifespan. Easily swap out the filter, with no tools required.

Reduced power consumption

High heat exchange efficiency can be maintained, reducing power consumption by 25 to 30%, compared to oil chillers with clogged condensers.*³

Installing Long Life Filters makes the cooling fins maintenance-free!

See how easy it is to use the Long Life Filter in this video.

URL <https://www.hyd.daikin.com/special/oilcon/longlifefilter/lp>



(The photo shows an example of installation with AKZ.)

Comments from active users of the Long Life Filter

We have been using the Long Life Filter for a year, and the cooling fins haven't become dirty. We no longer experience alarms due to clogging, ensuring our equipment operates smoothly.



Company A, with 370 units

The time spent on oil chiller maintenance has been reduced, resulting in a decrease in overall maintenance hours. From now on, we will equip new units with the Long Life Filters.



Company B, with 100 units

Clogging comparison

Measurement at factory site with high oil mist concentration (model: AKZ439)

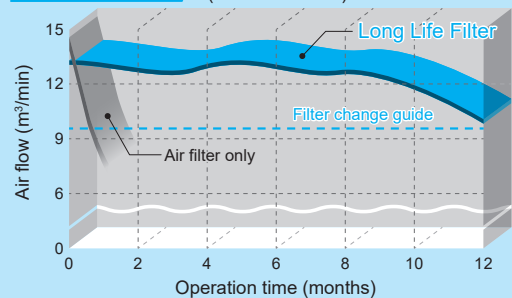

Specifications Both a filter and frame are required when placing the first order.

Frame model	Filter model	Oil chiller horsepower (HP)	Model representative of targeted oil chillers		Frame outer dimensions
			For Series 9	For Series 10	
AKZ9-OP-FR05	AKZ9-OP-LF05A	0.5	AKZ149, AKJ189, AKW149/189	—	W365 × H410 × D165
AKZ9-OP-FR12	AKZ9-OP-LF12A	1.2	AKZ329, AKJ359, AKC359, AKW329/359	—	W365 × H535 × D165
AKZ9-OP-FR15	AKZ9-OP-LF15A	1.5	AKZ439, AKJ459, AKW439/459	—	W365 × H635 × D165
AKZA-OP-FR05	AKZA-OP-LF05A	0.5	—	AKZ14A, AKJ18A, AKW14A/18A	W365 × H395 × D165
AKZA-OP-FR12	AKZA-OP-LF12A	1.2	—	AKZ32A, AKJ35A, AKW32A/35A	W365 × H520 × D165
AKZA-OP-FR15	AKZA-OP-LF15A	1.5	—	AKZ43A, AKJ45A, AKW43A/45A	W365 × H620 × D165
AKZA-OP-FR20	AKZA-OP-LF20A	2.0	AKZ569, AKJ569, AKC569, AKW569/589	AKZ56A, AKJ56A, AKW56A/58A	W470 × H620 × D165
AKZA-OP-FR30	AKZA-OP-LF30A* ⁴	3.0	AKZ909, AKJ909, AKW909/929	AKZ90A, AKJ90A, AKW90A/92A	W540 × H710 × D165
AKZA-OP-FR50	AKZA-OP-LF50A* ⁴	5.0	AKJ1509	—	W725 × H1180 × D165

*1. Note on models with a tank: The tank oil filler port cannot be opened or closed with the frame in place. Remove the frame before opening/closing the tank oil filler port. *2. This is based on a mist concentration of 0.5 mg/m³. In environments with excessive oil mist/dust, etc., it may be necessary to clean the cooling fins or change the filter more frequently than once a year. *3. This is an estimate based on our operation model. *4. 1 set comprising 2 filters (Two filters are used per frame.)

OIL COOLING UNIT



บริษัท นานดีอินเตอร์เทรด จำกัด
NANDEE INTER-TRADE CO., LTD.

314,316,318,320,322 ซอยจันทน์ 32 ถนนจันทน์ แขวงทุ่งวัดดอน เขตสาทร กทม. 10120

☎ : 0-2675-8239
LINE : @nandeeintertrade
f : nandeeintertrade
🌐 : www.nandee.co.th
✉ : marketing@nandee.co.th
sales@nandee.co.th